

Residual Oxygen Meter

PACK MASTER[®] / RO-105S

Operation Manual

With Warranty

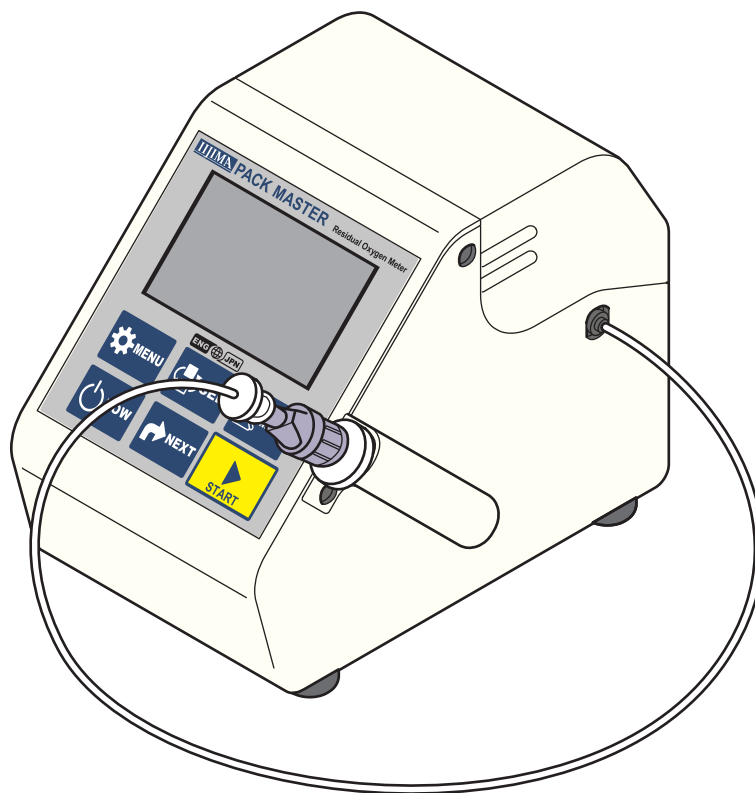

Thank you for purchasing the PACK MASTER.

The PACK MASTER is an analyzer that samples gas from bags, bottles, cans, etc., and measures the residual oxygen concentration (O₂) and gas replacement rate (REP).

This manual describes how to operate the PACK MASTER and the precautions that must be observed to ensure proper and safe use. Always read this manual and fully understand the operation before starting use.



Keep this manual near the device for quick reference at any time.

❖ Before starting use



1. Safety precautions (Always observe)

This section explains the precautions that must be observed to prevent injury to the user or other persons or damage to property.

- The following symbols classify and explain the degree of harm or property damage that may result if the contents of the symbols are ignored and the product is used improperly.

	Warning	This symbol indicates a dangerous situation that could result in fatal or serious injuries if the information is ignored and the product is handled incorrectly.
	Caution	This symbol indicates the extent of harm or damage that could potentially result in injury or physical damage if the information is ignored and the product is handled incorrectly.
	Note	This symbol indicates a situation in which the measurement could be adversely affected, preventing correct measurement results from being obtained if the information is ignored and the product is handled incorrectly.

- The types of information to be observed are categorized and indicated with the following symbols.

	This symbol indicates "Warnings", "Cautions", and "Notes" that must be observed.		This symbol indicates "Prohibited" matters that must not be conducted.		This symbol indicates "Instructions" that must always be enforced.
---	--	---	--	---	--

Warning

Suspend operation immediately when any abnormality occurs.



Continuing use can lead to fires or electric shocks. Immediately turn OFF the power switch and disconnect the power plug from the outlet. Contact the dealer from which you purchased the product for repairs.

Take care not to stab the human body with the needle.



A needle is used for the measurement. Handle it with extreme caution. There is a risk of blindness, puncture wounds, or cuts.

Do not touch the oxygen sensor with bare hands if it is leaking.



A highly concentrated acetic acid solution is used for the electrolyte inside the sensor. There is a risk of serious eye injury if the electrolyte gets into the eyes. Immediately rinse the eyes (including under the eyelids) with clean running water for at least 15 minutes, and immediately seek medical attention from an ophthalmologist. If the electrolyte gets on the skin, wash with plenty of water and seek immediate medical attention.

Perform measurements in an adequately ventilated room.

Do not place your face near the unit or smell odors during the measurement.



The PACK MASTER samples a mixture of low oxygen gas and discharges it into the atmosphere when the measurement is completed. Conducting measurements in a poorly ventilated room or taking a deep breath to smell the odors can cause the user to lose consciousness or feel unwell due to a lack of oxygen.

Do not touch the battery with bare hands if it is leaking.



There is a risk of serious eye injury or inflammation if the fluid leaking from the battery gets in the eyes or on the skin. Immediately wash with clean running water, and seek immediate medical attention.



Caution

Do not damage the power cord or power plug.



Do not damage, process, place heavy objects on, heat, place near a source of heat, forcibly bend, twist, or pull the power cord or plug. There is a risk of fire or electric shock resulting from core wire exposure, short-circuit, or breakage.

Do not use a power plug that is contaminated with foreign matter, such as dust.



There is a risk of fire or electric shock if the foreign matter absorbs moisture, etc., and causes an insulation fault.

Insert the power plug completely to the base.



There is a risk of electric shock or fire from heating if the power plug is inserted incompletely.
* Do not use a damaged plug or loose outlet.

Use only the specified battery.



Failure to do so could prevent the device from operating.

<Permitted batteries>

- Nickel-metal hydride batteries (Eneloop)
- Alkaline batteries

<Prohibited batteries>

- Do not use any type of battery other than that listed above.

Handle the battery correctly.



The battery could rupture or ignite if handled incorrectly. If the battery fluid leaks, it could corrode the device or contaminate hands or clothing.

Always observe the following cautions.

- Make sure the polarity (+ and -) is correct when inserting the battery.

- Remove the batteries when suspending use for a long time.

- Do not leave spent batteries in the device.

- Safely dispose of spent batteries with the designated method.



- Do not use new and old batteries or different types of batteries together.

- Do not heat or disassemble the batteries or place them in water or fire.

- Do not put batteries together with metal items.

- Do not use the battery if the outer sheath is peeling.

Do not use in an environment, including temperature, humidity, pressure, vibration, dust, or acidic or corrosive gases, that could adversely affect the device.



Failure to observe this could result in faults.



Note

[Measurement atmosphere gas]

Mixed gas

The instrument is adjusted for measurements for gas mixtures of nitrogen (or argon) and oxygen. Do not use other gas mixtures, as accurate measurement may not be possible.

[Use prohibited gases]

• Oxidizing gases

Oxidizing gases, such as sulfur dioxide and hydrogen sulfide, can cause high readings and can cause the sensor performance to drop quickly.

• Reducing gases

Reducing gases, such as fluorine, chlorine, bromine, iodine, and ozone can cause high readings and significant degradation of the sensor performance in a short time.

• Other obstructive gases

Hydrogen chloride and nitrogen oxide will be indicated at high levels, and hydrogen will be indicated at a low level. In either case, the sensor performance can degrade significantly in a short time.

[Operating environment]

Static electricity

In rare cases, static electricity can cause the measured value to vary instantaneously or cause the device to stop operating. If the device operation stops, turn the power OFF and ON.

Before starting use

2. Confirmation of package contents

When unpacking the PACK MASTER, confirm that the following items are included and that the contents have not been damaged. If any parts are missing or damaged, contact the dealer from which you purchased the product.

Package contents

PACK MASTER x 1 unit

Main unit
Sampling adapter

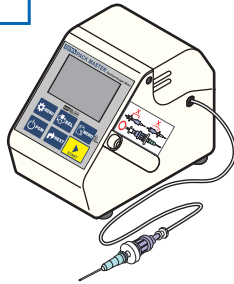

Oxygen sensor (WAGNIT®) x 1 unit

(Model: WA-SGF2)

Already mounted in the main unit housing.



AC adapter x 1 unit

(Model: AC-105)



Needle (vertical slot type) x 2 pcs.



Needle (horizontal slot type) x 1 pc.

Switch the type when measuring a sample, such as an adhesive, that can easily clog the needle.

Adhesive rubber x 20 pcs.

Size: 20mm x 100mm x t1

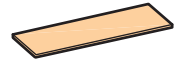

Maintenance kit (model: MK-105)

Membrane filter x 3 pcs.



Check valve x 1 pc.



Sampling tube with fitting
(length: 50cm) x 3 pcs.



O-ring for housing x 1 pc.



AA alkaline batteries x 4 pcs.

Already mounted in the main unit.

Operation manual and warranty (this document) x 1 copy



Handy User's Guide x 1 copy

Oxygen sensor warranty x 1 copy



"PACK MASTER®" is a registered trademark of the Iijima Electronics Corporation product.

"WAGNIT®" is a registered trademark of the Iijima Electronics Corporation oxygen sensor.

Accessories (options)

* Refer to the instructions enclosed with each product for details on handling.

Quick Sampler

(Model: PO-1)

Eliminates the need to attach adhesive rubber or pierce needle through adhesive rubber.

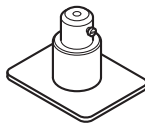

Quick Sampler 2

(Model: PO-2)

Suitable when the top of the sample is indented, such as with a cup.



Printer (printer cable sold separately)

(Model: CBM-910II-40)

Use to print out the measured values.



- Ordering consumable parts

Printer paper (Model: RP5860) 20-roll set

Ink ribbon (Model: IR91B) 5 ribbon set

Gas sampling glass tube (Model: GS-2)

Use this tube to collect small amounts of sample gas from the container, such as a can, bottle, or ampule.

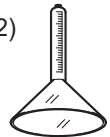

Can opener (Model: KO-1)

Use this opener to measure the remaining oxygen concentration in a can.

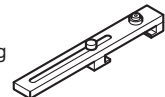

Opener (Model: KO-X1)

Use this opener to measure the remaining oxygen concentration in a bottle.



DO Measuring Device (Model: MA-300)

Connect to PACK MASTER, measure dissolved oxygen (DO) in a liquid.

Storage case (Model: ROPSC1)

Storage case dedicated for the RO-105 series.

When purchasing consumable parts for new replacements or spare part inventory, please refer to the following section, and contact the dealer from which you purchased the product.

[Accessories (Consumable parts)]

Oxygen sensor (WAGNIT®)

(Model: WA-SGF2)

Always confirm the information in "3. Precautions for oxygen sensor" before purchasing.



AC adapter (Model: AC-105)

Output 6 VDC

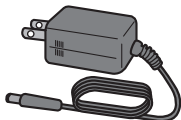

Needle (TERUMO NN-2116R-12)

Vertical slot type, 12-pc. set



Needle (Model: T-30-12)

Horizontal slot type, 12-pc. set



Membrane filter (5-pc. set)

(Model: RO-MF)



Adhesive rubber (Model: RG-1)

Size: 20mm x 100mm x t1
100-piece set

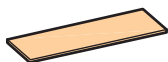

Check valve (3-pc. set)

(Model: RO-CV)



Sampling tube with fitting (5-pc. set)

(Model: RO-SC) Length: 50cm



Sampling adapter

(Model: SA-5)

Needle (vertical slot type), membrane filter, check valve, tube set



Maintenance kit (model: MK-105)

<Contents>

Membrane filter x 3 pcs.

Check valve x 1 pc.

Sampling tube with fitting x 3 pcs.

O-ring for housing x 1 pc.

O-ring for housing (10-pc. set)

(Model: P-8-10)



Main cover (Model: RO-C)

With knurled screws for the main cover

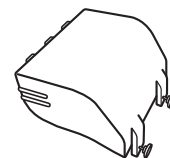

3. Precautions for oxygen sensor (Model: WA-SGF2)

In principle, the oxygen sensor (WAGNIT®) Model: WA-SGF2 will deteriorate over time and become unusable at the end of its service life. Please understand and agree to the following precautions before making a purchase.

■ WA-SGF2 warranty term

When the sensor is already mounted in the main unit, the warranty is valid for one year from the date of shipment from Iijima Electronics Corporation.

When purchasing the single sensor unit, the warranty is valid for one year from the date that the sensor package is opened. (Note that the maximum warranty term is two years, including the storage term* and warranty term.)

* "One year storage" is only in the case of using in Japan.

■ Warranty details

Iijima Electronics Corporation will send a "malfunction replacement" if the sensor becomes unusable due to a malfunction within one year after the sensor package is opened. (The "malfunction replacement" is not a new part. The usable service life will correspond to the remaining warranty term.)

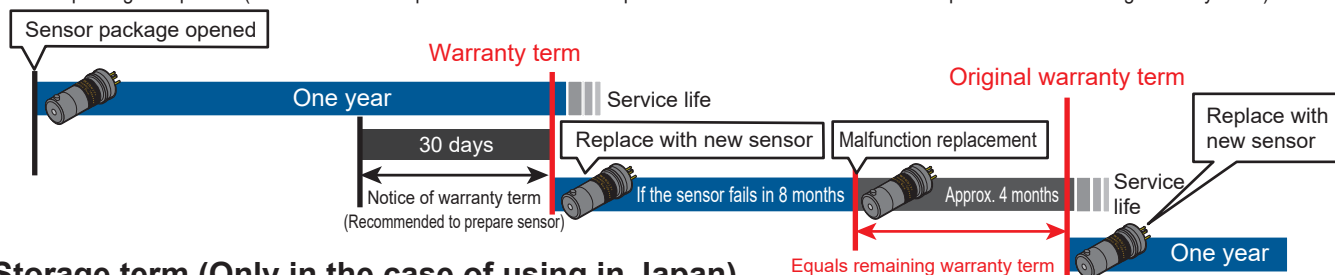

■ Storage term (Only in the case of using in Japan)

Only when this instrument is used in Japan, the oxygen sensor can be stored in an unopened state for up to one year. The sensor can be stored as a spare sensor, thus preventing missing measurements if the sensor suddenly becomes unusable due to a malfunction.

There is a very slight chemical reaction even during storage. Thus, the sensor should be opened and used within one year. If the sensor is stored for longer than the maximum storage period of one year, it can still be used, but the warranty term and service life will be reduced by the number of days it was stored.

<Image of storing one spare sensor and replacing once a year>

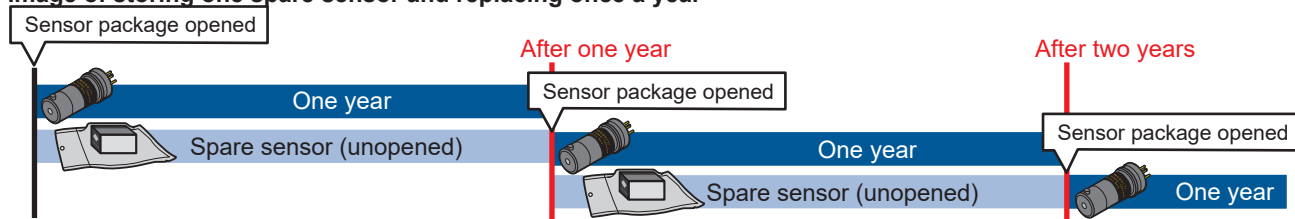

The oxygen sensor in the unopened package must be set on its side in the bag and stored in a temperature range of 0 to 30°C. If the storage conditions are not satisfied, the sensor may not operate properly when opened.

Contents

Before starting use	
1. Safety precautions (Warning, Caution, Note)	
2. Confirmation of package contents Package contents, Accessories (options), Accessories (Consumable parts)	
3. Precautions for oxygen sensor (Model: WA-SGF2)	
Names and functions of each part	1
Main unit section	1
Housing section / Oxygen sensor (WAGNIT®) /	2
Operation Methods	3
1. Preparing for use	3
Using the PACK MASTER with batteries / Using the PACK MASTER with 100 VAC power	3
2. Preparing for measurement	3
Power ON/OFF	3
Switching the measurement mode / Automatic stability decision function / Key Lock / Unlock function	4
Japanese / English selection function	5
3. Calibration	6
Span calibration	6
Zero calibration	7
4. Measurement and recording	8
Preparing to measure	8
O ₂ Measurement (Auto mode) / O ₂ measurement (Manual mode)	9
Memory function / Confirming the measurement history	10
Erasing the measurement history / Guidance display function [Procedure display]	11
Various Settings and Functions	12
Setting the O ₂ displays [O ₂ DISP SET]	12
Setting the time [TIME SET]	13
Time zone selection function [TIMEZONE]	14
Output setting [OUT SET]	15
Checking for clogging [CLOG CHECK]	16
Initialization [INITIALIZE]	18
Erasing the entire history [CLR ALL HST]	19
Connecting to an external device (Serial communication)	20
Connecting a printer / Connecting to a personal computer	20
Maintenance	21
Replacing the oxygen sensor / Replacing the needle	21
Replacing the membrane filter / Replacing the check valve	22
Replacing the sampling tube with fitting	22
Troubleshooting	23
Troubleshooting	23
Displaying the product information	23
Error Messages	27
Product Specifications	30
After Sales Service	33

Names and functions of each part

Main unit section

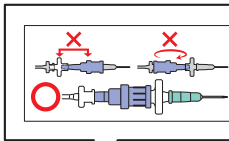
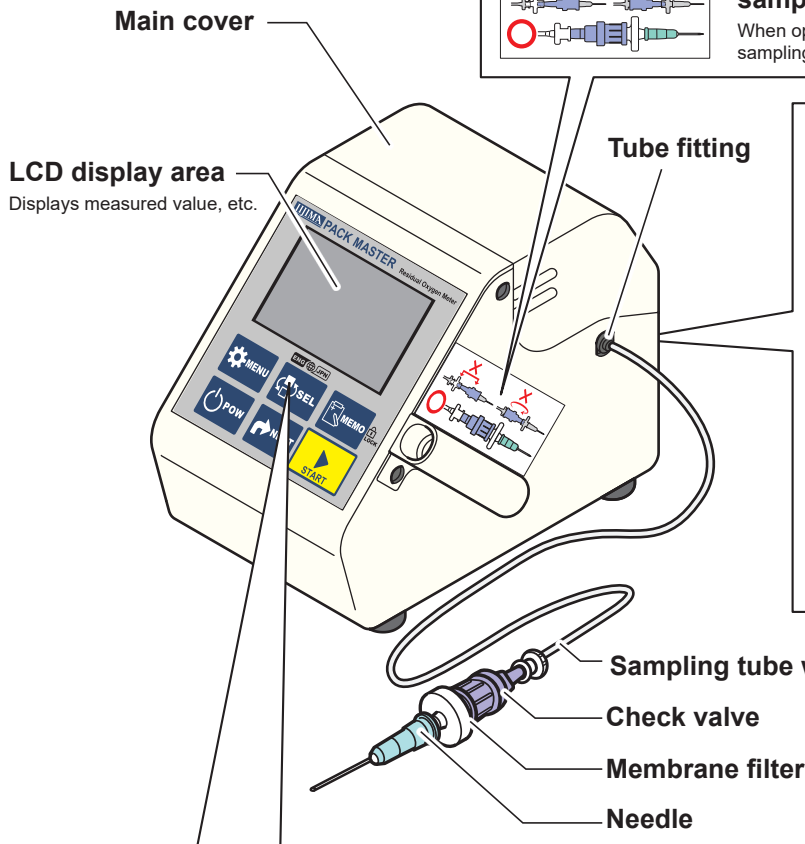

The correct order and direction for connecting the sampling adaptor are indicated with a sticker.

When operating or storing the unit, refer to this sticker and confirm that the sampling adaptor is correctly connected.

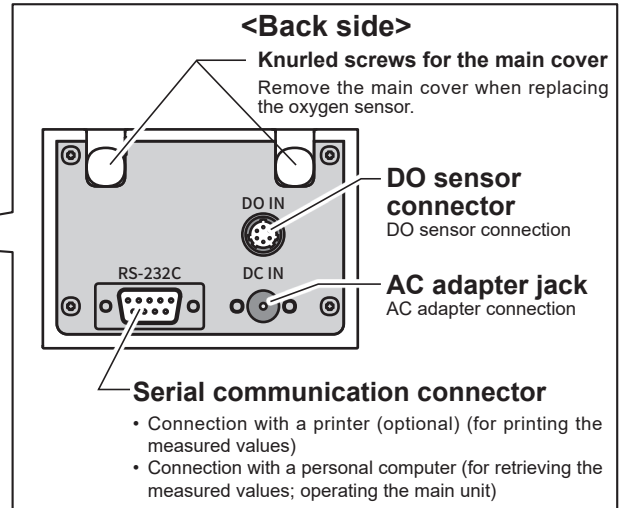

<Base> Battery box

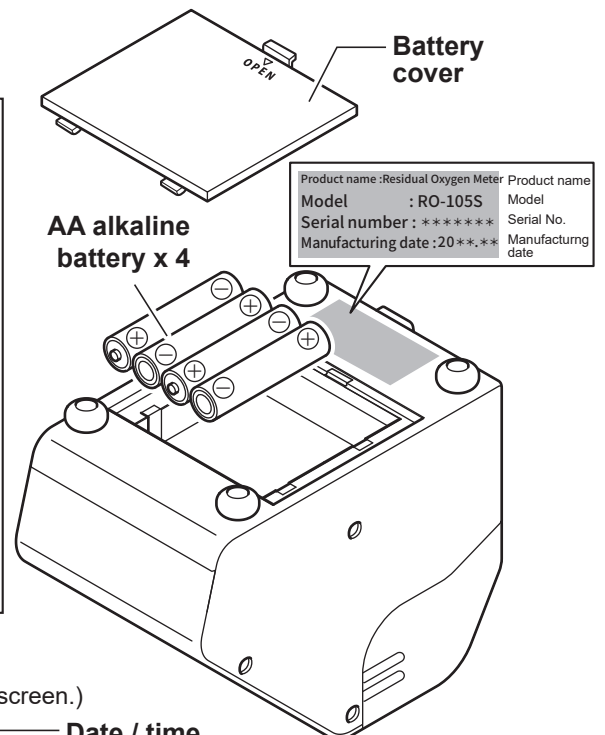

	MENU key	Press to display the menu or return to the previous screen
	SELECT key	Press to switch to the measurement history, or DO measurement mode (when DO sensor is connected) Hold for 3 seconds to switch displayed language between Japanese and English
	MEMORY key	Press to save a measured value or delete a measured value Hold for 3 seconds to lock or unlock operations
	POWER key	Press to turn the power ON or OFF
	NEXT key	Press to switch the measurement mode or selection
	START key	Press to start the measurement, start calibration, enter a selection, or stop operation

<LCD display area>

(The following example shows the Measurement Complete screen.)

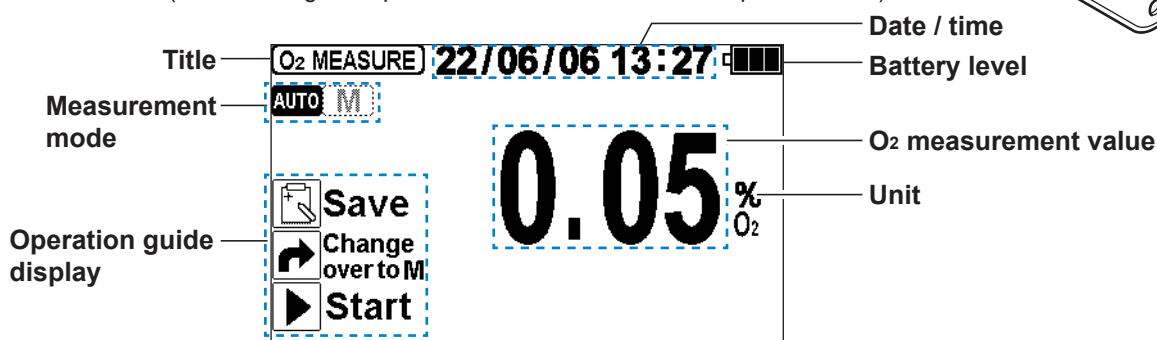

Housing section

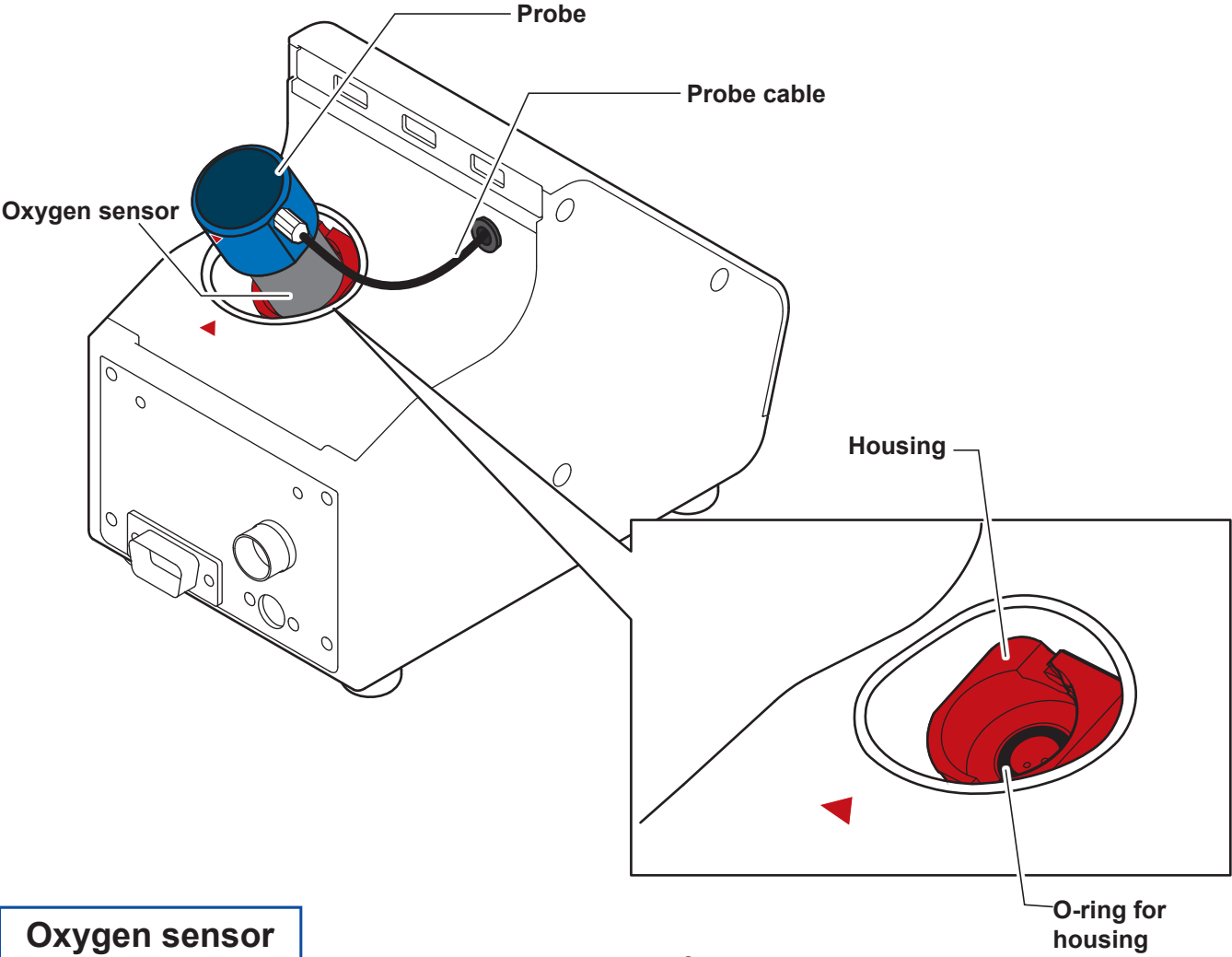

Oxygen sensor

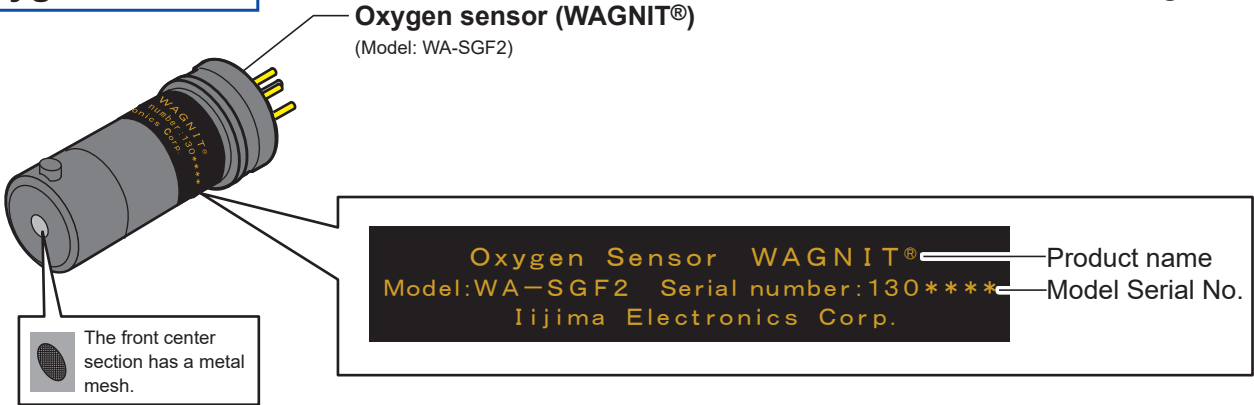

❖ Operation Methods

1. Preparing for use

Using the PACK MASTER with batteries

The batteries are mounted before shipment, so the PACK MASTER can be used right away.
When replacing the batteries, use AA alkaline batteries or nickel-metal hydride batteries (ENELOOP).

Using the PACK MASTER with 100 VAC power

Always use the enclosed AC adapter.



Caution

- Always remove the batteries when using the AC adapter or when suspending the use of the instrument for a long time and putting the unit into storage. The instrument could be damaged if the battery fluid leaks.
- Always use the enclosed AC adapter. Failure to do so could damage the instrument.

2. Preparing for measurement

Power ON/OFF

* After turning the power OFF, wait at least 2 seconds before turning it ON again.



Note

- The calibration or measured value could be affected if the ambient temperature changes. In this case, turn the power OFF with the oxygen sensor set, and wait at least 30 minutes for the temperature to stabilize.
- Always remove the tip of the needle from the sample before turning the power OFF.

1. Press .

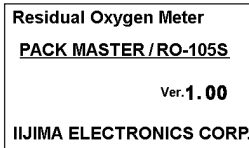

The power turns ON, and the software version displays.
(Approx. 4 seconds)

* The displayed details will vary according to the version.



Sensor warranty term notification function (Displayed when the self-diagnosis function determines that there are 30 days or less to the end of the oxygen sensor warranty term.)

Display when 25 days are remaining



Display when 0 days are remaining (end of warranty term)



* The warranty is valid for one year from the date of shipment.
(When the sensor is replaced, one year from the date the new sensor package is opened.)

* The display on the left is a guideline.
The self-diagnosis results are also displayed.

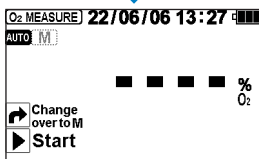

The Measurement Standby screen opens.

* The screen on the left shows the Auto mode and Concentration % O₂ setting.

2. Press again.



The atmosphere is automatically suctioned. After the screen on the left opens, the power turns OFF.

* When the DO sensor is connected, there is no atmosphere suction operation.

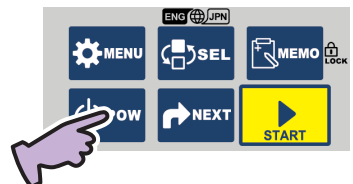

Switching the measurement mode

The mode is set to Auto as the default when the unit is shipped. When  is pressed in the Auto mode, the cycle of operations from pump and suction of sample gas, automatic stability decision, and holding of indicated value is completed automatically.

The Auto mode is usually used. Measurements can be taken in the Manual mode in the following cases.

- When the contents are visible through the packaging, and you want to suction the gas while adjusting the tip of the needle so that it does not pierce the contents.
- When sampling approx. 6 mL of gas using the optional "Gas sampling glass tube (model: GS-2)" and you want to suction the gas while adjusting the needle so that the liquid is not suctioned.

1. Press .

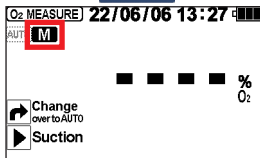

The mode switches to the Manual mode.

"M" (MANUAL) is selected.

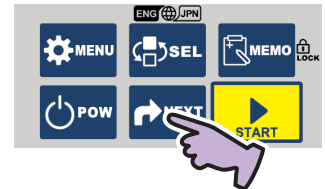

2. Press .

The mode returns to the Auto mode.

Automatic stability decision function

When taking a measurement, the indication value at the most stable state is automatically held.

The timing for deciding the stability is different for the Auto mode and Manual mode.

<Auto mode>

Press .

The measurement starts, and the Stability Decision screen opens.

The decision is completed when a beep sounds and the stabilized measured value appears.



Progress status bar display



<Manual mode>

Hold down  and suction the gas.

The pump operates only while the key is held down, and the stability decision starts when the key is released.

The decision is completed when a beep sounds and the stabilized measured value appears.

Key Lock / Unlock function

Lock the keys to prevent operations other than measurement and history display. Use this function to prevent accidental setting changes, calibration, measured value switching, or history erasing. Until the keys are unlocked, the locked state is retained even if the power is turned OFF, the batteries are removed, or the AC adapter is disconnected.

1. Hold down for 3 seconds or longer on the O₂ MEASURE Screen.

"Locked" displays.

The key lock function is enabled while "Locked" is displayed.

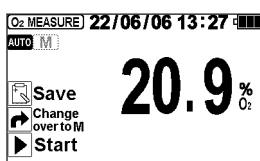

Hold down for 3 seconds or longer

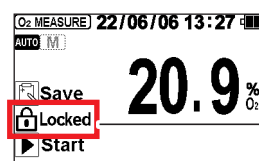
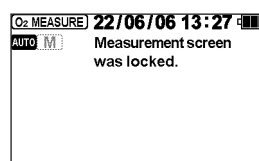

"Locked" display



2. Unlock the lock function by pressing again for 3 seconds or longer.

The "Locked" display disappears.

Japanese / English selection function

Japanese is the factory default setting for the display. The displayed language can be switched between Japanese and English from any screen.

Usually, the language can be switched between Japanese and English from any screen if the power is ON. Note that the language cannot be switched during the following operations. The language can be switched once the operation is finished or canceled and the built-in pump has stopped.

- During O₂ measurement operation
- During calibration (span calibration/zero calibration) operation
- During the clogging check operation

1. With the power turned ON, hold down for 3 seconds or longer.

The display language will switch from Japanese to English.
(The displayed contents are saved.)

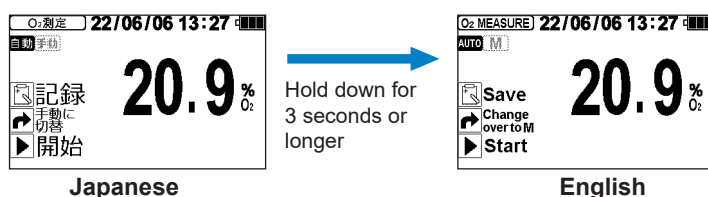

2. When is held down again for 3 seconds or longer, the language will return to Japanese.

<When using in countries or regions other than Japan>

By using the “Time zone selection function,” the time zone can be set to the standard of the region where the instrument is being used.

Refer to “Time zone selection function” on page 14 for the operation methods.

3. Calibration

The calibration process adjusts the instrument measured value so that the span point and zero point during O₂ measurement match the sensor output when the reference gases (atmosphere, nitrogen) were measured.

Span calibration

Perform span calibration once a day before starting measurements. Ideally, span calibration should be performed when the temperature of the oxygen sensor and temperature sensor are sufficiently stable, such as first thing in the morning before operating the air conditioning system.

If the deviation from the true value can be tolerated by about 5%, span calibration should be performed when the oxygen concentration in the atmosphere is 20%O₂ or less, or 22%O₂ or more. In this case, the error will be 0.05% O₂ when the measurement concentration is 1%O₂.

1. Place the needle in the atmosphere.

2. Press .

The MENU screen opens, and "CAL" is selected (flashes).

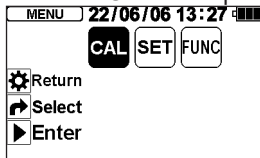

3. Press .

The O₂ CAL screen opens.

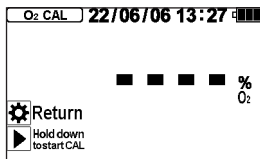

* If even one measurement has been taken, the previous measured value will display.



4. Hold down  for 1 second or more.

The calibration starts, and the Stability Decision screen opens. A beep sounds, CAL complete appears (approx. 1 second), and then the O₂ MEASURE screen opens. The calibration process is completed.

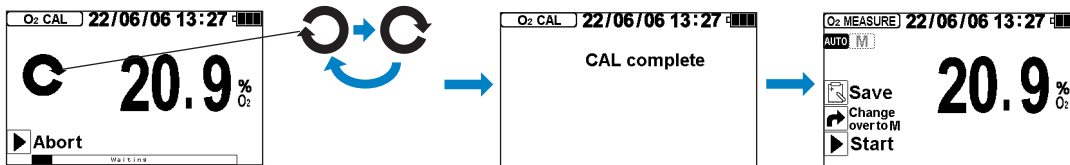

The calibration value is saved even if the power is turned OFF, the batteries are removed, or the AC adapter is disconnected.

If the "Sensor error" message appears, refer to the section "Error Messages" (pages 27) and confirm and remedy the situation.



Caution

The measured value (calibration value) may be high or low if a strong impact is applied on the instrument unit or if the temperature changes drastically. In this case, wait for some time and then perform span calibration again.

Zero calibration

To accurately measure low concentrations when measuring O₂, use nitrogen gas for calibration.

1. Set the needle so it can suction the nitrogen gas.

2. Press .

The MENU screen opens, and "CAL" is selected (flashes).

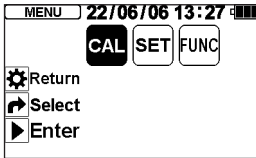

3. Press .

The O₂ CAL screen opens.

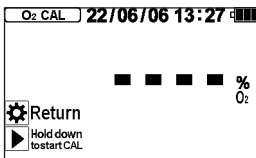

* If even one measurement has been taken, the previous measured value will display.



4. Hold down  for 1 second or more.

The calibration starts, and the Stability Decision screen opens. A beep sounds, CAL complete appears (approx. 1 second), and then the O₂ MEASURE screen opens. The calibration process is completed.

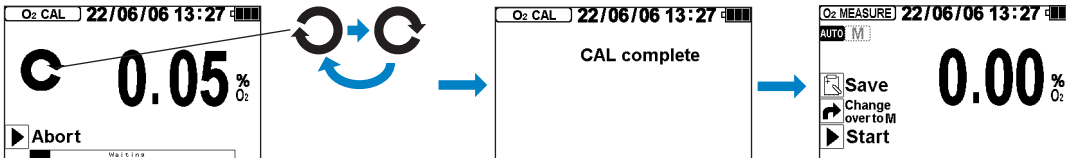

The calibration value is saved even if the power is turned OFF, the batteries are removed, or the AC adapter is disconnected.

If the "Sensor error" message appears, refer to the section "Error Messages" (page 27) and confirm and remedy the situation.



Caution

The measured value (calibration value) may be high or low if a strong impact is applied on the instrument unit or if the temperature changes drastically. In this case, wait for some time and then perform zero calibration again.

<When nitrogen gas cannot be prepared>

Initialize the instrument and then perform span calibration.

Refer to the sections "Initialization" (page 18) and "Span calibration" (page 6) for details on the operation methods.

4. Measurement and recording

Preparing to measure



Note

- It may not be possible to measure if the sample gas quantity is less than 6mL.
- A measurement can be taken even if the inside of the sample is depressurized, but if the package's internal pressure is less than -30kPa, a correct measurement value may not be obtained. Note that depressurization will occur easily after gas suction, especially if the gas quantity is low. In this case, a measurement can be taken using the optional "gas sampling glass tube (model: GS-2)".
- The measurement may take longer if the inside of the sample is depressurized.
- A measurement can be taken even if the inside of the sample is pressurized. However, if the package's internal pressure is higher than +40kPa, the components could break when the needle is pierced, or a correct measured value may not be obtained. In this case, a measurement can be taken using the optional "gas sampling glass tube (model: GS-2)".

1. **Shift the contents in the pack to one side and hold with a hand to create a space for piercing the needle.**
2. **Attach the enclosed adhesive rubber over the air space.**
Adhesive rubber cutting dimension reference: 1cm x 1 cm square
3. **Lightly press down on one side of the bag, and set the needle in the sample gas.**

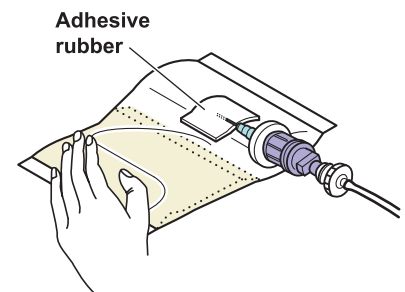

Do not suction the contents.

A measurement error will occur if powder, etc., gets clogged in the needle.

Note that the minute amount of liquid in the sample gas is blocked by the membrane filter.



Warning

Take care not to stab the human body with the needle. There is a risk of blindness, puncture wounds, or cuts.



Caution

- If pressure is applied into the pack from the set needle using an air gun, etc., the internal pump or sensor could be damaged. If the needle is clogged, replace it with a new needle.
- Continuing use with a clogged needle, membrane filter, check valve, or sampling tube with fitting will deteriorate the sensor.



Note

- If the liquid is accidentally suctioned, the membrane filter that has absorbed the liquid will not pass the gas, preventing a correct measurement. Note that if the liquid contains oil, it might pass through the membrane filter. Refer to "Maintenance" (pages 21 to 22) and replace the needle, membrane filter, check valve, and sampling tube with fitting contaminated with liquid or oil with new parts. Check the housing to confirm that the suctioned liquid and oil have not adhered to the oxygen sensor. If adhered, remove the oxygen sensor and clean the inside of the housing. The metal mesh at the front center of the oxygen sensor can be cleaned by lightly wiping with tissue paper.
- Using the needle, membrane filter, check valve, and sampling tube with fitting in a clogged state may prevent a correct measurement.

O₂ Measurement (Auto mode)

The measurement starts automatically when  is pressed. Refer to the section "Switching the measurement mode" (page 4) for details on switching between the auto mode and manual mode.

1. When the Measurement Standby screen is displayed, press .

The measurement starts, and the Stability Decision screen opens.
The decision is completed when a beep sounds and the stabilized measured value appears.

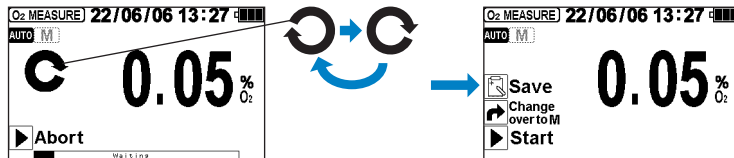
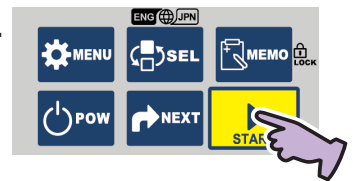

The value indicated when  is not lit is read.

- If the "Sensor error", "Sensor unstable", or "Negative pressure detected" message appears, refer to the section "Error Messages" (page 27) and confirm and remedy the situation.
- To stop the measurement while deciding the stability, press . The measurement will be aborted.

2. To record the measured value, press  on the Measurement Complete screen.

The measured value is saved in the main unit.
Refer to section "Memory function" (page 10) for details.



O₂ measurement (Manual mode)

The pump operates only while  is held down. Refer to the section "Switching the measurement mode" (page 4) for details on switching between the auto mode and manual mode.

1. If the Manual mode is not enabled, press .

This step is not required if the Manual mode is enabled.
The selected measurement mode is saved even when the power is turned OFF.

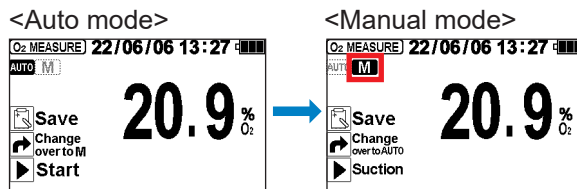

2. With the Measurement Standby screen displayed, hold down  (Suction).

The pump operates only while  is held down.
In the manual mode, the stability decision is canceled while the pump is operating.
The stability decision starts when the key is released, and the pump stops.
(If the measurement value fluctuates, the Stability Decision screen will appear.)
The decision is completed when a beep sounds and the stabilized measured value appears.

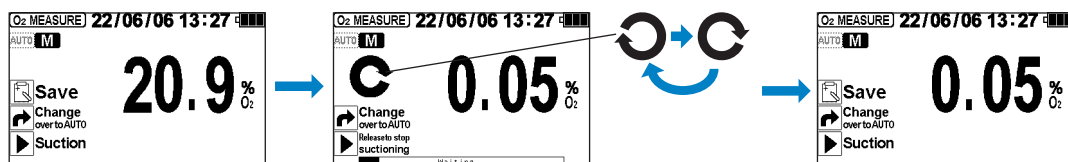
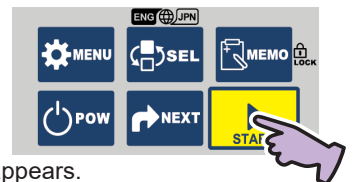

The value indicated when  is not lit is read.

3. To record the measured value, press  on the Measurement Complete screen.

The measured value is saved in the main unit.
Refer to section "Memory function" (page 10) for details.



Memory function

The measured value is not automatically saved in the internal memory. Using the following steps, up to 300 values can be saved and retained in the internal memory. When 300 values are exceeded, the oldest data is automatically deleted.

Press  on the Measurement Complete screen.

The measured value for which the stability has been automatically decided is saved. "Save complete" appears, and the current date and time, and O₂ measurement value are saved.

The saved details are retained even if the power is turned OFF, the batteries are removed, or the AC adapter is disconnected.

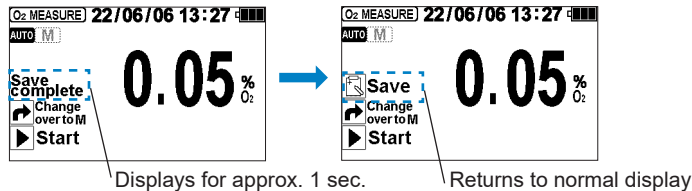

Confirming the measurement history

The saved measured values can be displayed and confirmed later.

1. When the Measurement Standby screen is displayed, press  .

The HISTORY screen opens.

Immediately after the screen switches, three measurements with the latest date and time are displayed.

(When DO sensor is connected and recorded, the DO measurement history is also displayed at the same time.)

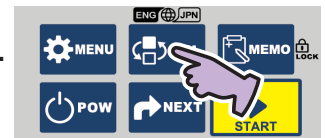
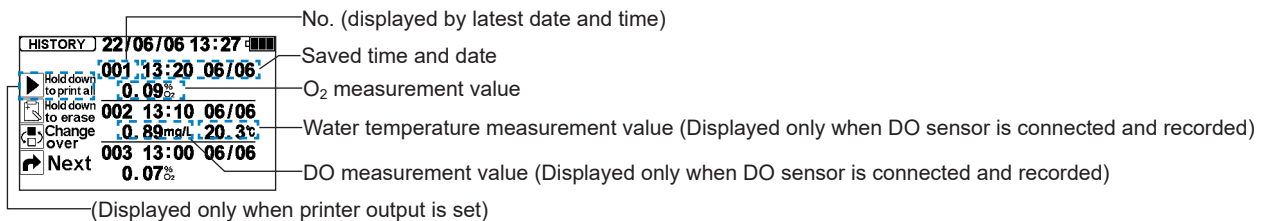

2. When  is pressed, the older data is displayed three items at a time.

When the key is held down, the page will switch.

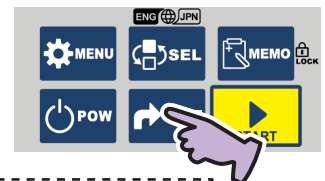
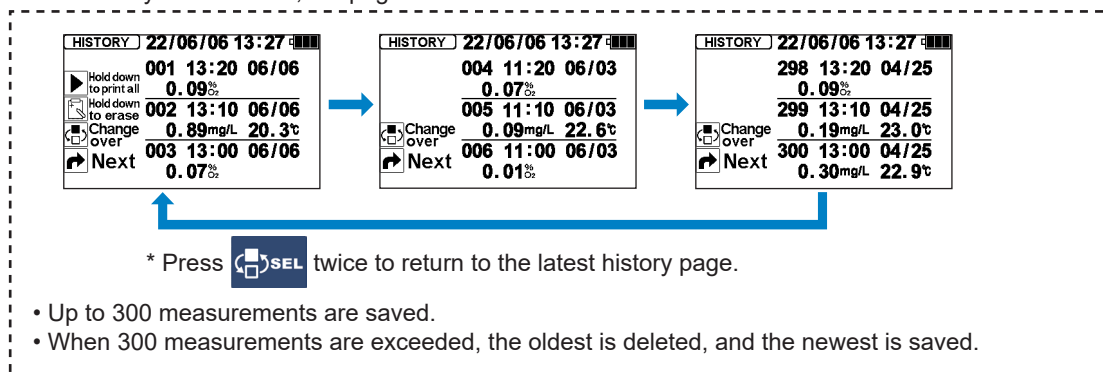

3. Press  .

The O₂ MEASURE screen opens.



Erasing the measurement history

The latest measurement value records can be deleted one item at a time.
Use this when a measurement value has been accidentally saved.

Hold down  for 1 seconds or longer on the HISTORY Screen.

“Erase Complete” displays for approx. one second, and then contents of the data saved last are erased from the internal memory.

The display returns to the HISTORY screen.

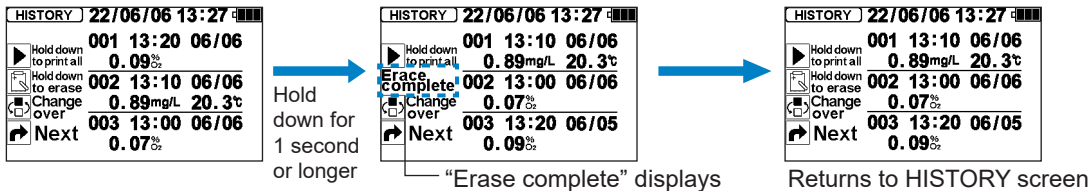

To erase the entire history, refer to the section “Erasing the entire history” (page 19).

Guidance display function [Procedure display]

This function displays and guides the remedy procedures for malfunctions or error messages that may occur during use.

If an error message appears, the screen will switch to the one showing the procedures to be taken depending on the displayed details.

(Some guidance displays do not require switching to the procedure display.)

Follow the instructions on the screen to remedy the error.

<Example 1> When “Negative pressure detected” is displayed

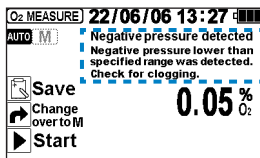

As a remedy, perform a clogging check (refer to page 16).

<Example 2> When “Sensor error” is displayed

Press  (procedure display). The remedy procedure will display.

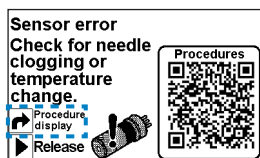

Procedure display

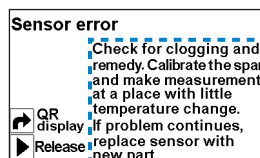

As a remedy, perform a clogging check (refer to page 16) or span calibration (refer to page 6).

When  (QR display) is pressed again, the screen returns to the Error Message screen.

Press  to cancel the display.

❖ Various Settings and Functions

Setting the O₂ displays [O₂ DISP SET]

The display method can be changed to display the O₂ measurement value as gas replacement rate.

$$\text{Gas replacement rate (\%)} = \left(1 - \frac{\text{Oxygen concentration (\%O}_2\text{)}}{20.9}\right) \times 100$$

1. When the Measurement Standby screen is displayed, press .

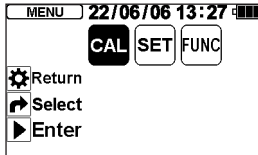

The MENU screen opens.
Immediately after opening, "CAL" is selected (flashes).



2. Press .

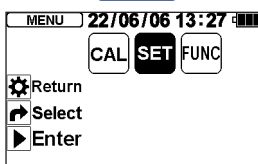

The cursor moves, and "SET" is selected (flashes).

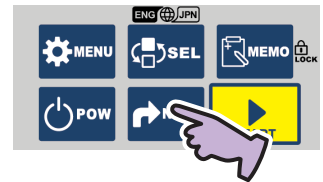

3. Press .

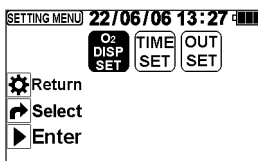

The SETTING MENU screen opens.
Immediately after opening, "O₂ DISP SET" is selected (flashes).



4. Press .

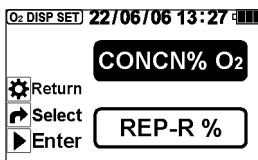

The O₂ DISP SET screen opens.
"CONCN% O₂" (currently set O₂ display) is selected (flashes).

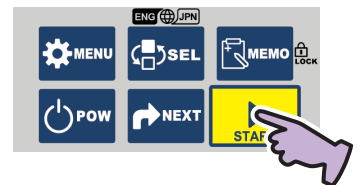

5. Press .

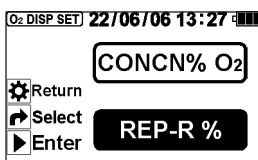

The cursor moves, and "REP-R%" is selected (flashes).

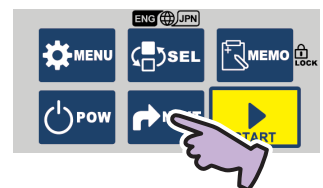

6. Press .

The setting change screen displays for approx. 1 second, completing the changes to the settings.

(The screen returns to the SETTING MENU screen.)

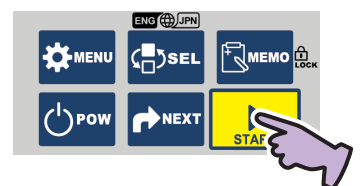
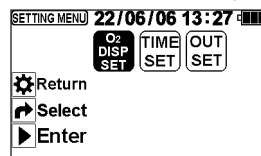
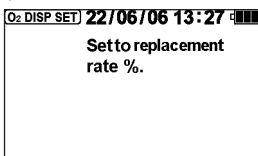

Setting the time [TIME SET]

Set the time if the displayed time has deviated.

1. When the Measurement Standby screen is displayed, press .

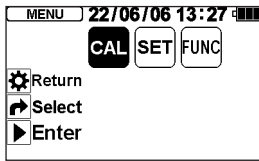

The MENU screen opens. Immediately after opening, "CAL" is selected (flashes).



2. Press .

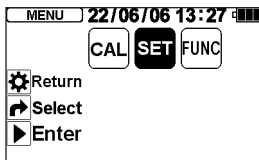

The cursor moves, and "SET" is selected (flashes).

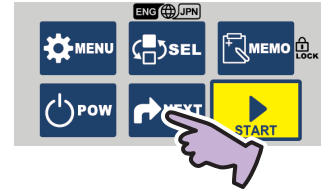

3. Press .

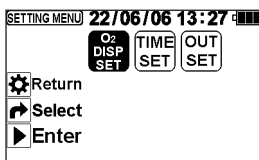

The SETTING MENU screen opens. Immediately after opening, "O2 DISP SET" is selected (flashes).

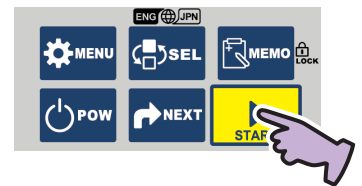

4. Press .

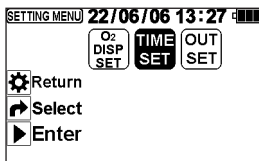

The cursor moves, and "TIME SET" is selected (flashes).

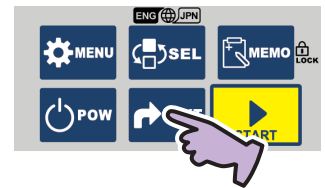

5. Press .

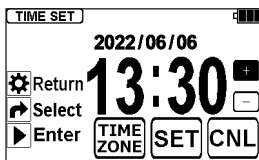

The TIME SET screen opens. Immediately after opening, "+" is selected (flashes).



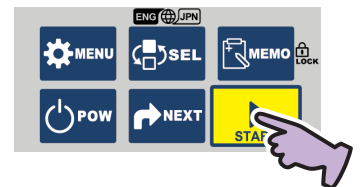

* The example on the left shows the current date as 2022 June 6 and the time as 13:30.

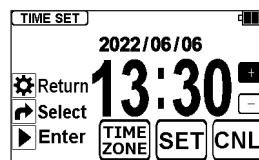

6. Change the time with the following steps.

Press . The cursor will move in the order of  →  →  →  → . When  is pressed, the cursor function will activate.



-  ... The time is advanced by one minute.
* Hold down the key to advance the time 10 minutes in 0.5-second increments.
-  ... The time is returned by one minute.
* Hold down the key to return the time 10 minutes in 0.5-second increments.
-  ... The internal clock can be changed to the local standard time (refer to page 14).
-  ... The displayed time is set, and the SETTING MENU screen opens.
-  ... The time changes are canceled, and the SETTING MENU screen opens.

When  is pressed, the time changes are aborted, and the SETTING MENU opens.

7. Select  or , and press .

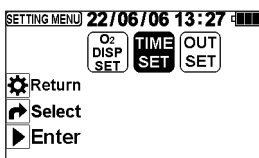

The time setting is completed or canceled, and the screen returns to the SETTING MENU.



Time zone selection function [TIMEZONE]

When using the instrument in a country or region other than Japan, the instrument's internal clock can be changed to the local UTC (coordinated universal time).

A time zone is a geographical region that uses the same standard time. The deviation from the UTC (coordinated universal time) is expressed with a positive or negative sign, such as "UTC+9:00". Japan's designated standard time is "UTC+9", so the factory default setting is "UTC+9:00".

1. Refer to the section "Setting the time" on page 13 and proceed with steps 1 to 5.

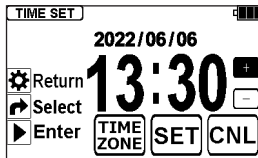

The "TIME SET" screen opens.
Immediately after opening, "+" is selected (flashes).

2. Press twice.

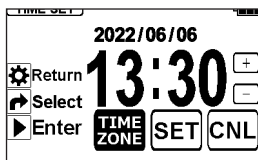

The cursor moves, and "TIMEZONE" is selected (flashes).

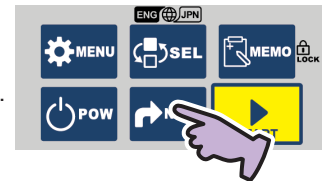

3. Press .

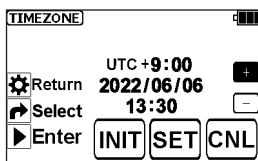

The "TIME SET" screen opens.
Immediately after opening, "+" is selected (flashes).

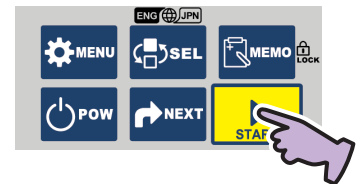

4. Change the time zone with the following steps.

Press . The cursor will move in the order of → → → → . When is pressed, the cursor function will activate.

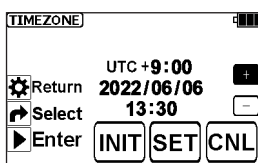

- ... The displayed UTC is advanced by one unit.
- ... The displayed UTC is returned by one unit.
- ... The time zone is returned (initialized) to Japan's time zone "UTC+9:00".
- ... The displayed UTC is set, and the TIME SET screen opens.
- ... The time zone selection is canceled, and the TIME SET screen opens.

5. Select , and press .

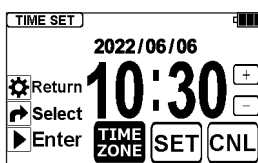

The internal time is changed to the selected time zone, and the TIME SET screen opens.

* The display on the left shows the time after changing to "UTC+6:00".



6. Press . The SETTING MENU opens.

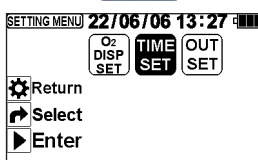

The time zone selection is completed and the screen returns to the SETTING MENU.



Output setting [OUT SET]

Complete the settings to use the printer (optional, sold separately) or to use a personal computer (prepared by the user) to read the measured values or perform control. (The factory default setting is “No Output”.)

1. When the Measurement Standby screen is displayed, press .

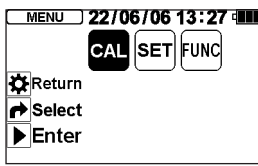

The MENU screen opens. Immediately after opening, “CAL” is selected (flashes).



2. Press .

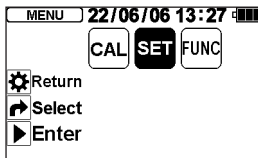

The cursor moves, and “SET” is selected (flashes).



3. Press .

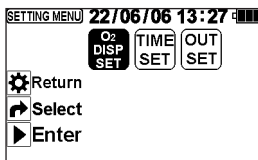

The SETTING MENU screen opens. Immediately after opening, “O2 DISP SET” is selected (flashes).



4. Press  twice.

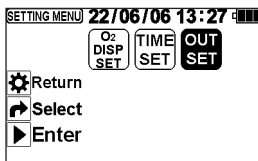

The cursor moves, and “OUT SET” is selected (flashes).

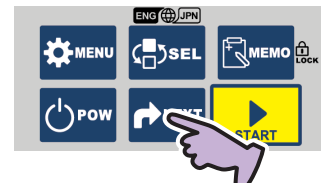

5. Press .

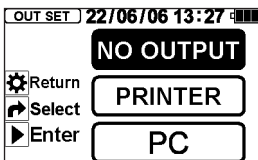

The OUT SET screen opens. The currently set output destination is selected (flashes).



6. Press  and select the output destination.

<Example> To connect to the printer, select “PRINTER”.

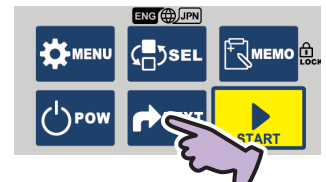
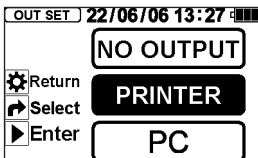

7. Press .

The OUT SET complete screen displays for approx. 1 second, completing the changes to the output settings.

(The screen returns to SETTING MENU.)

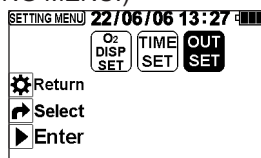
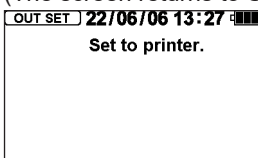

Checking for clogging [CLOG CHECK]

If the gas path, such as the needle or tubing, is clogged, the gas cannot be suctioned properly, and correct measurement cannot be made. A clogging check is performed to check for any clogging.

The clogging check makes a decision using the pressure sensor that is built into the gas path.

If the gas path is not clogged, the pressure will be between 0 and -5kPa. If it is completely clogged, the pressure will be approx. -40kPa.

Check for clogging in the following types of situations.

- (1) If “Negative pressure detected” displays while measuring the sample.
- (2) If the measurement takes longer than usual, or if “Sensor unstable” displays.
- (3) If the measured value is higher or lower than usual.

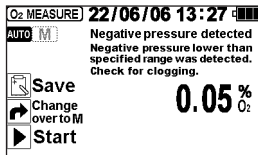

“Negative pressure detected” display

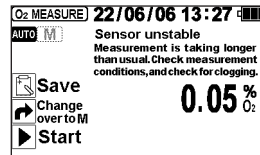

“Sensor unstable” display

1. When the Measurement Standby screen is displayed, press .

The MENU screen opens. Immediately after opening, “CAL” is selected (flashes).

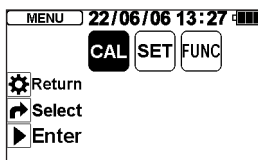

2. Press twice.

The cursor moves, and “FUNC” is selected (flashes).

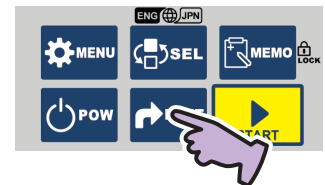
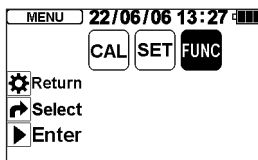

3. Press .

The FUNC MENU screen opens.

Immediately after opening, “CLOG CHECK” is selected (flashes).

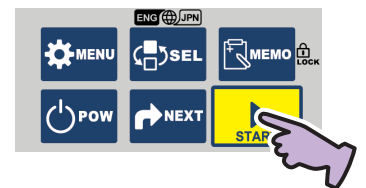
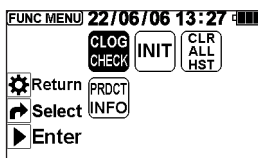

4. Press .

The CLOG CHECK screen opens.

<Display example>

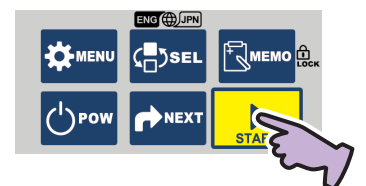
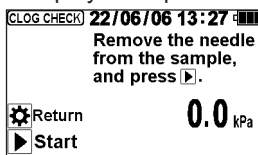

5. Follow the on-screen instructions and steps below to check for clogging.

<Example 1> To check for clogging in the needle

(1) Expose the tip of the needle to the atmosphere and press  .

The pump operates for 5 seconds and decides whether there is clogging.

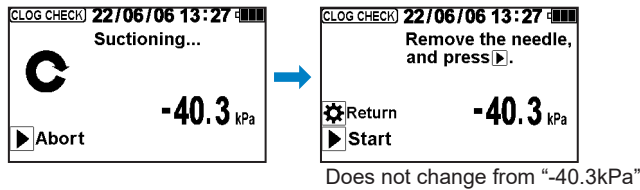

(2) Remove the needle and press  .

The pump operates for five seconds and decides again whether there is clogging.

If the value fluctuates and the negative pressure is eliminated, it can be decided that the needle was clogged.

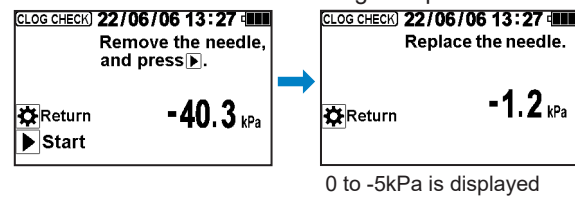

(3) Replace the needle with a new part.

Refer to the section “Maintenance” (pages 21 to 22).

If the negative pressure is not eliminated even after the needle is removed and checked, remove the parts in order of the membrane filter and check valve, and decide whether there is any clogging.

<Example 2>

When sample cannot be suctioned because of negative pressure and not clogging



(1) Remove the needle from the sample and expose the tip of the needle to the atmosphere.

Then, press  .

The pump operates for 5 seconds and decides whether there is clogging.

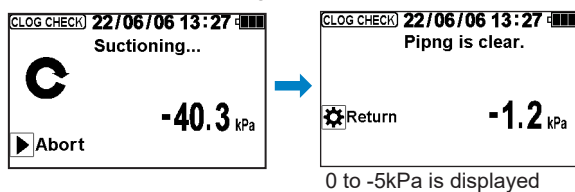
If the value fluctuates and the negative pressure is eliminated, it can be decided that the sample was at a negative pressure.



- If  is pressed again while checking for clogging, the pump will stop.
- If  is pressed, the clogging check is aborted, and the Function Menu screen opens.
- This function operates with automatic suction regardless of the selected measurement mode (auto/manual).

Initialization [INITIALIZE]

Use this function if the measured value is incorrect after calibration. It resets the O₂ display setting, calibration value, measurement mode, and output setting to the factory default settings. The initialization will reset any arbitrary settings to the factory default settings.

1. When the Measurement Standby screen is displayed, press .

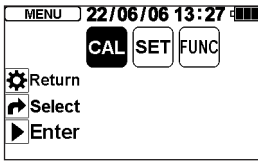

The MENU screen opens. Immediately after opening, "CAL" is selected (flashes).



2. Press  twice.

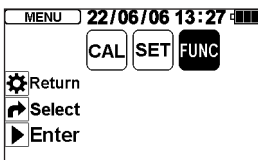

The cursor moves, and "FUNC" is selected (flashes).

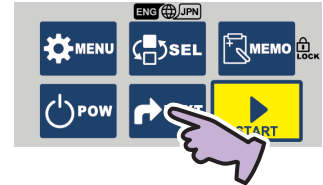

3. Press .

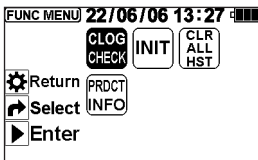

The FUNC MENU screen opens. Immediately after opening, "CLOG CHECK" is selected (flashes).



4. Press .

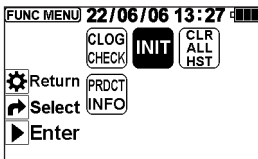

The cursor moves, and "INIT" is selected (flashes).

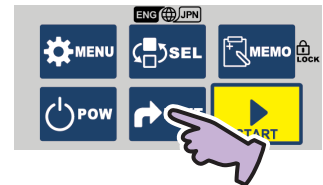

5. Press .

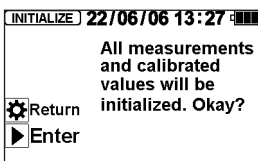

The INITIALIZE screen opens.

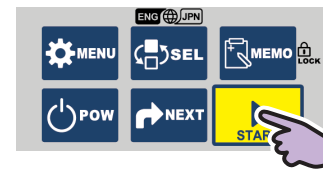

6. Press .

The INITIALIZE complete screen displays for approx. 1 second, completing initialization. (The screen returns to FUNC MENU.)

Initialization returns the span and zero calibration values to the factory default values. The O₂ display setting is reset to "CONC %O₂", the measurement mode to "Auto mode", and the output setting to "NO OUTPUT".

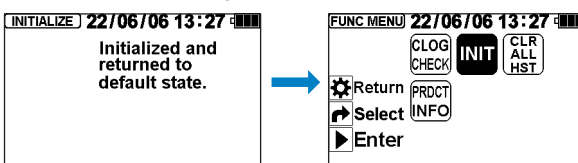
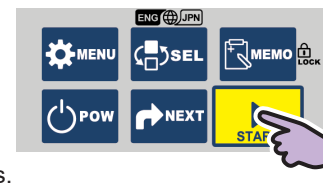

Erasing the entire history [CLR ALL HST]

The measurement data saved in the internal memory with the “Memory Function” (refer to page 10) can be erased in a batch. Note that the data cannot be redisplayed once it has all been erased.

1. When the Measurement Standby screen is displayed, press .

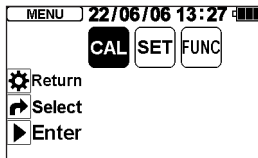

The MENU screen opens. Immediately after opening, “CAL” is selected (flashes).



2. Press  twice.

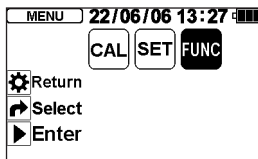

The cursor moves, and “FUNC” is selected (flashes).

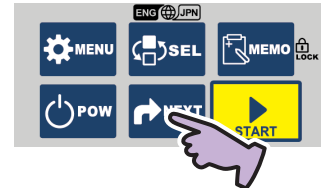

3. Press .

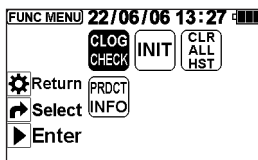

The FUNC MENU screen opens. Immediately after opening, “CLOG CHECK” is selected (flashes).

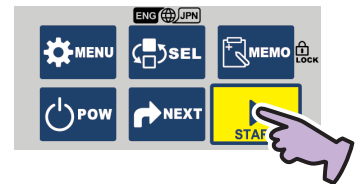

4. Press  twice.

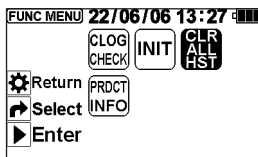

The cursor moves, and “CLR ALL HST” is selected (flashes).

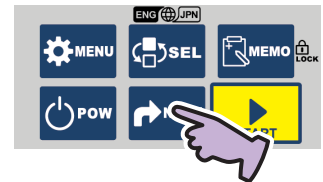

5. Press .

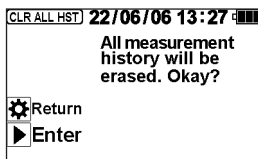

The CLR ALL HST screen opens.

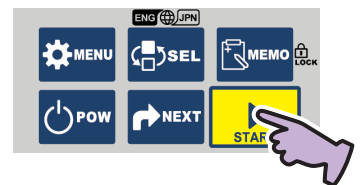

6. Press .

The CLR ALL HST complete screen displays for approx. 1 second, completing erasing the entire history. (The screen returns to FUNC MENU.)

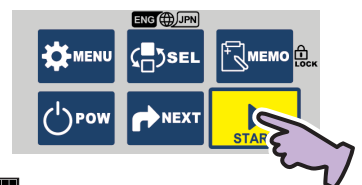
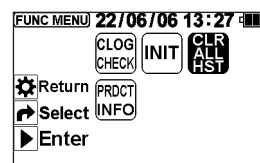
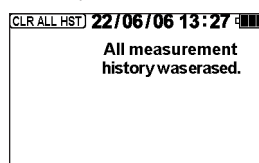
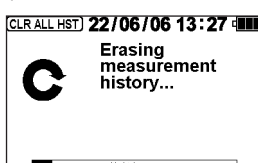

Connecting to an external device (Serial communication)

Connecting a printer

The measurement data can be printed out by connecting a printer (optional, sold separately). A printer cable is required to connect the printer. (RS-232C serial cross cable 25-pin male to 9-pin female)

1. Refer to page 15 and set the output setting destination to “PRINTER”.
2. Connect the PACK MASTER and printer.
3. Press  on the Measurement Complete screen.

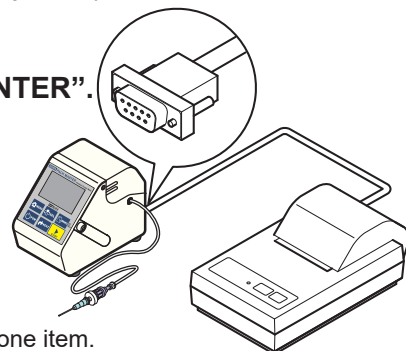

The measured values will be saved in the memory and simultaneously printed out one item.

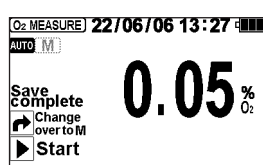

[Example of printing]

```

2022/06/06 12:57 O2: 0.05%
2022/06/06 13:00 REP.: 99.8%
2022/06/06 13:10 DO: 0.51mg/L TEMP: 20.4 C
2022/06/06 13:20 SATR.: 50.0% TEMP: 20.1 C
    
```

O₂ measurement value
O₂ replacement rate
DO measurement value
DO saturation rate



Printing all of the saved data

When the Measurement Standby screen is displayed, press . The HISTORY screen will open.

When  is held down for 3 seconds or longer, all saved data will be printed out.

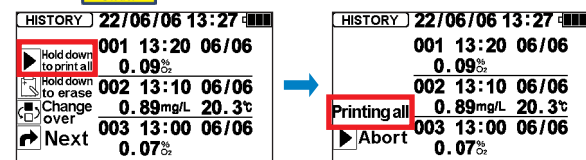

The data is printed from the latest data.

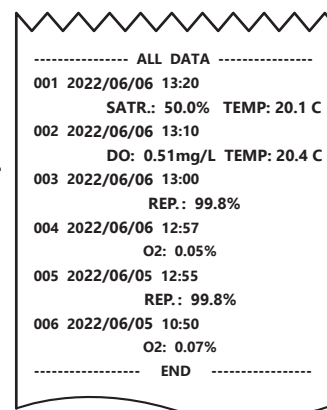

• Press  to forcibly stop the printing.

Connecting to a personal computer

The measurement data can be read and the devices can be controlled by connecting to a personal computer (prepared by the user). A serial cross cable (RS-232C) is required, and the personal computer must have a serial terminal (RS-232C). If the personal computer does not have a serial terminal, prepare a USB to RS-232C converter.

1. Refer to page 15 and set the output setting destination to “PC”.
2. Connect the PACK MASTER and personal computer.
3. Refer to the following table and set the communication settings.

[Communication settings]

Item	Setting
Baud rate	9600bps
Data length	8bit
Stop bit	1bit
Parity	None

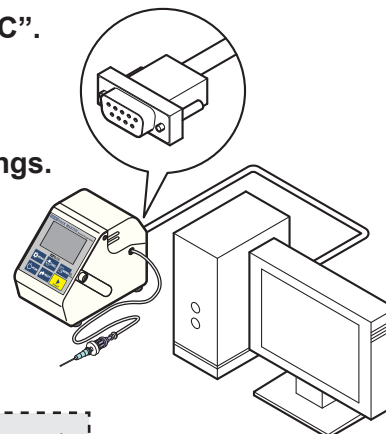

* Contact the dealer from which you purchased the product for details on the output measurement data and main unit control specifications.

Maintenance

Replacing the oxygen sensor

1. Loosen the knurled screws fixing the main cover on the back of the main unit. Open and remove the main cover.
2. Turn the sensor counterclockwise and pull it straight out of the housing (red).
3. Pull the sensor out of the probe (blue).

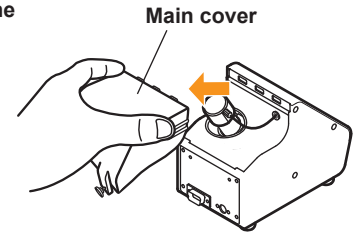
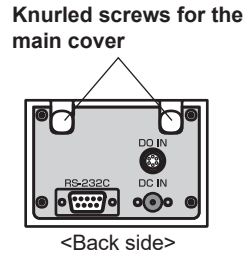

Pulling the probe cable with force could damage the wires.

Caution

4. Confirm that the O-ring for the housing is properly mounted on the groove.

If the O-ring has deviated, firmly press it in.
If the O-ring has deteriorated (cracked, etc.), replace it with a new part.

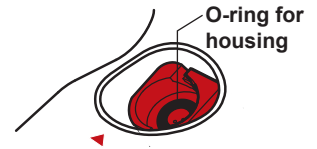
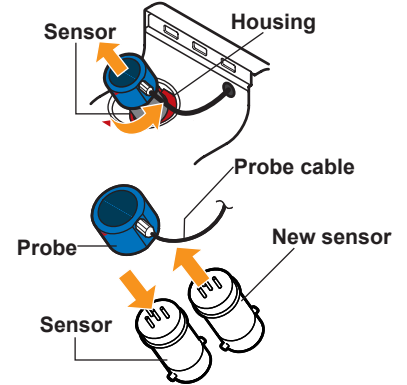

5. Align the new sensor with the insertion hole on the probe (blue) and insert it.

When mounting a new oxygen sensor, always remove the short pin first.
Dispose of the removed short pin and spent oxygen sensor according to the local rules.
(The short pin contains metal parts, and the oxygen sensor contains lead.)
Leave the oxygen sensor mounted on the main unit until it reaches its service life.



6. Align the protrusion on the sensor's tip into the slot on the housing (red) and insert. Turn the sensor clockwise and align it to the ▲ mark.

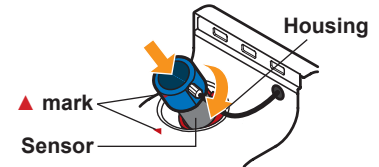

7. Mount the main cover and tighten the knurled screws for the main unit cover.

Replacing the needle

If the needle clogs because of accidental suction of powder or liquid, etc., it can be replaced with a new part to resume measurements.

1. Remove the needle from the membrane filter.
2. Attach a new needle.
Dispose of the spent needle according to local rules. It cannot be reused.

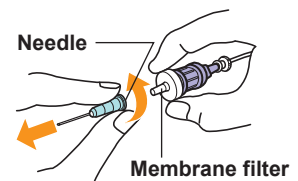

Warning

Take care not to stab the human body with the needle. There is a risk of blindness, puncture wounds, or cuts.

Replacing the membrane filter

If liquids enter the membrane filter, the gas path will be clogged, and measurement will not be possible. If liquids accidentally get inside, replace the membrane filter to resume measurements. (Note that if the liquid contains oil, it might pass through the membrane filter. Carefully observe the passage state when measuring samples containing oil.)

1. Remove the needle from the membrane filter.
2. Remove the membrane filter from the check valve.
Hold the rotating section of the check valve with fingers so that it does not spin while removing the membrane filter.
3. Attach the new membrane filter.
Hold the rotating section of the check valve with fingers so that it does not spin while attaching the membrane filter.
4. Attach the needle.
Since the liquid also passes through the needle, replace the needle with a new one if there is residual liquid or clogging.

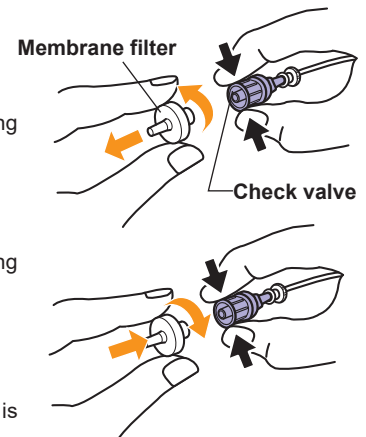

Replacing the check valve

Check the state of the check valve. If it is clogged or if the operation is faulty (gas backflow), replace it with a new check valve

1. Remove the membrane filter and needle from the check valve.
When removing the parts from the check valve, hold the rotating section of the check valve with fingers so that it does not spin.
2. Remove the check valve from the sampling tube with fitting.
3. Attach a new check valve onto the sampling tube with fitting.
Note Attach so that the narrower side of the check valve faces the sampling tube. The gas will not be suctioned properly if installed backward.
4. Attach the membrane filter and needle.
If the needle or membrane filter is clogged, replace it with a new part.

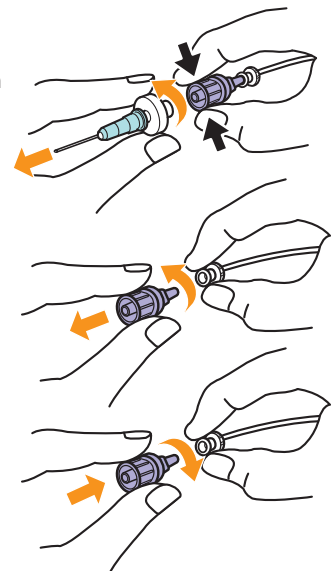

Replacing the sampling tube with fitting

The tube must be replaced with a new part if it is clogged with powder or liquid.

The tube and fitting section are connected beforehand.
If the parts are disconnected, do not attempt to reattach them.
Instead, replace them with a new part.

1. Hold the tube fitting section on the main unit side with fingers, and pull the tube off the main unit.
2. Attach the new sampling tube with fitting.
Push the end of the tube firmly and deeply into the tube fitting part to fix it in place.
Push in about 8 to 9mm from the end of the tube.

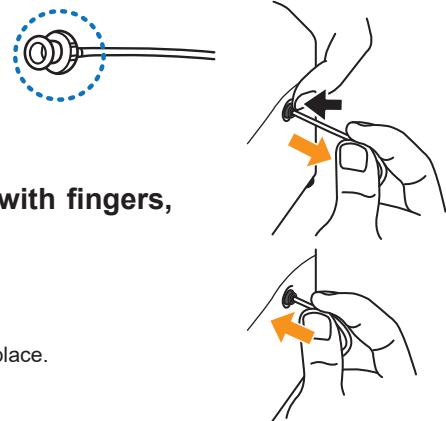

Note

- If the needle, membrane filter, and check valve are attached loosely, the gas may leak out, and a correct measurement value may not be obtained. Tighten the parts securely until there is no play.
- If the sampling tube with fitting is not pushed in firmly and deeply, the gas may leak out, and a correct measurement value may not be obtained. Make sure to push the tube in firmly and deeply.

❖ Troubleshooting

Troubleshooting

If you suspect any malfunction or trouble, always perform the following confirmation and remedy before requesting repairs.

If the symptoms do not subside, refer to the section “After Sales Service” (page 33) and contact the dealer from which you purchased the product.

Displaying the product information

When inquiring, you may be asked to provide the product information, which can be displayed with the following steps. Thank you for your cooperation.

1. When the Measurement Standby screen is displayed, press .

The MENU screen opens, and “CAL” is selected (flashes).

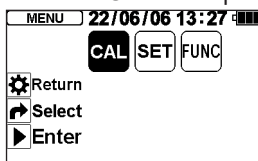

2. Press  twice.

The cursor moves, and “FUNC” is selected (flashes).

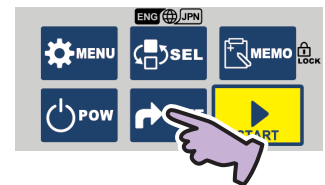
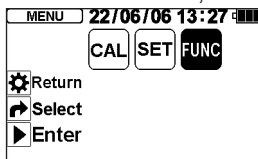

3. Press .

The FUNC MENU screen opens. Immediately after opening, “CLOG CHECK” is selected (flashes).

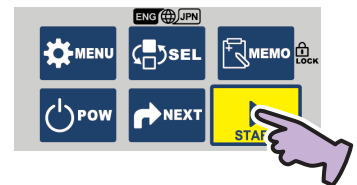
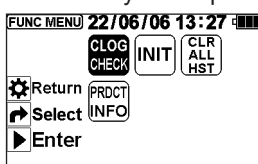

4. Press  three times.

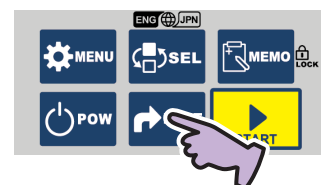
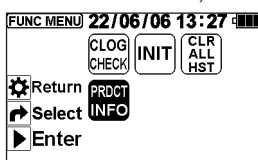

The cursor moves, and “PRDCT INFO” is selected (flashes).

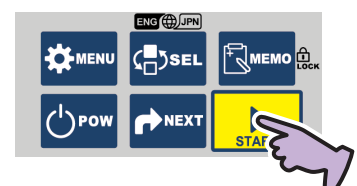
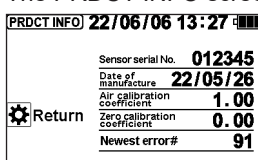

5. Press .

The PRDCT INFO screen opens.



Symptom	Check	Action	Reference page
The power does not turn ON. The display does not turn ON.	Did you press  ?	Press  .	3
	Are the batteries set?	Insert the batteries.	
	Are the batteries old?	Replace the batteries with new ones.	
	Are the batteries inserted in the right direction?	Reinsert the batteries in the right direction.	
	Is 100 VAC power supplied?	Connect the AC adapter.	
	Is the AC adapter correct?	Use the enclosed AC adapter.	
	If the symptoms do not improve even after taking the above actions, the main unit may be faulty.	Make a request for repairs.	33
The displayed O ₂ measurement value is low.	Was the span calibrated?	Take sufficient time to stabilize and then calibrate the span. (If an approx. 5% deviation from the true value can be tolerated, the span should be calibrated when the oxygen concentration in the atmosphere is 20% O ₂ or less, or 22% O ₂ or more as a guide.)	6
	Has water or foreign matter gotten between the oxygen sensor and housing?	Remove the oxygen sensor and clean the inside of the housing. Lightly wipe the metal mesh at the center of the oxygen sensor surface with tissue paper, etc., to remove any moisture or foreign matter. Replace the needle, membrane filter, check valve, and sampling tube with new parts.	21
	Is the oxygen sensor wet, or have crystals formed on the surface?	Replace the oxygen sensor with a new part. (Contact the dealer from which you purchased the product if the warranty is still valid.)	21 33
	If the symptoms do not improve even after taking the above actions, the main unit may be faulty.	Make a request for repairs.	33
The displayed O ₂ measurement value is high.	Was the span calibrated?	Take sufficient time to stabilize and then calibrate the span. (If an approx. 5% deviation from the true value can be tolerated, the span should be calibrated when the oxygen concentration in the atmosphere is 20% O ₂ or less, or 22% O ₂ or more as a guide.)	6
	Was a sample with a high concentration of O ₂ just measured?	Measure the atmosphere once and then measure the same again. The value can be high immediately after a high concentration sample was measured.	
	Is the connection of the needle, membrane filter, check valve, or sampling tube loose?	Securely tighten the connection for the needle, membrane filter, check valve, or sampling tube.	21 22
	Is the needle, membrane filter, check valve, or sampling tube clogged?	Check for clogging. If clogged, unclog the part or replace it with a new part. If the symptoms do not improve, make a request for repairs.	16 21,22 33
	Is the needle, membrane filter, check valve, or sampling tube damaged?	Replace the damaged part with a new part.	21 22
	Is the oxygen sensor correctly mounted? ----- Is the O-ring for the housing deviated?	Align the ▲ mark on the probe (blue) with the ▲ mark on the housing (red). ----- Firmly mount the O-ring for the housing in the groove.	21
	Is the oxygen concentration in the atmosphere 20% O ₂ or less, or 22% O ₂ or more?	Calibrate the span.	6
	If the symptoms do not improve even after taking the above actions, the main unit may be faulty.	Make a request for repairs.	33

Symptom	Check	Action	Reference page
The displayed O ₂ measurement value is zero. Zero is displayed even after the span is calibrated.	Is the oxygen sensor correctly mounted?	Correctly mount the oxygen sensor onto the probe (blue).	21
	Has water or foreign matter gotten between the oxygen sensor and housing?	Remove the oxygen sensor and clean the inside of the housing. Lightly wipe the metal mesh at the center of the oxygen sensor surface with tissue paper, etc., to remove any moisture or foreign matter. Replace the needle, membrane filter, check valve, and sampling tube with new parts.	21 22
	Is the oxygen sensor wet, or have crystals formed on the surface?	Replace the oxygen sensor with a new part. (Contact the dealer from which you purchased the product if the warranty is still valid.)	21 33
	Is the probe cable damaged or disconnected?	Make a request for repairs.	33
	If the symptoms do not improve even after taking the above actions, the main unit may be faulty.	Make a request for repairs.	33
The displayed O ₂ measurement value and calibration value do not change.	Is the check valve mounted in the correct direction?	Re-mount in the correct direction so that the narrow side of the check valve faces the sampling tube.	22
	Is the connection of the needle, membrane filter, check valve, or sampling tube loose?	Securely tighten the connection for the needle, membrane filter, check valve, or sampling tube.	21 22
	Is the needle, membrane filter, check valve, or sampling tube clogged?	Check for clogging. If clogged, unclog the part or replace it with a new part. If the symptoms do not improve, make a request for repairs.	16 21,22 33
	Is the needle, membrane filter, check valve, or sampling tube damaged?	Replace the damaged part with a new part.	21 22
	Is the oxygen sensor correctly mounted? ----- Is the O-ring for the housing deviated?	Align the ▲ mark on the probe (blue) with the ▲ mark on the housing (red). ----- Firmly mount the O-ring for the housing in the groove.	21
	If the symptoms do not improve even after taking the above actions, the main unit may be faulty.	Make a request for repairs.	33





Symptom	Check	Action	Reference page
The O ₂ measurement values fluctuate. The measurement takes time.	Is the connection of the needle, membrane filter, check valve, or sampling tube loose?	Securely tighten the connection for the needle, membrane filter, check valve, or sampling tube.	21 22
	Is the needle, membrane filter, check valve, or sampling tube clogged?	Check for clogging. If clogged, unclog the part or replace it with a new part. If the symptoms do not improve, make a request for repairs.	16 21,22 33
	Is the needle, membrane filter, check valve, or sampling tube damaged?	Replace the damaged part with a new part.	21 22
	Are there any factors that could cause the measurement environment temperature to change drastically? (Close to the air conditioning blow-off port, heating appliance, etc.)	Take the measurement in a room with little temperature change, where it is not affected by air conditioning.	
	Is the oxygen sensor correctly mounted? ----- Is the O-ring for the housing deviated?	Align the ▲ mark on the probe (blue) with the ▲ mark on the housing (red). ----- Firmly mount the O-ring for the housing in the groove.	21
	Has water or foreign matter gotten between the oxygen sensor and housing?	Remove the oxygen sensor and clean the inside of the housing. Lightly wipe the metal mesh at the center of the oxygen sensor surface with tissue paper, etc., to remove any moisture or foreign matter. Replace the needle, membrane filter, check valve, and sampling tube with new parts.	21 22
	(Only for O ₂) Is the oxygen sensor wet, or have crystals formed on the surface?	Replace the oxygen sensor with a new part. (Contact the dealer from which you purchased the product if the warranty is still valid.)	21 33
	If the symptoms do not improve even after taking the above actions, the main unit may be faulty.	Make a request for repairs.	33
The O ₂ measurement value flashes.	The zero calibration may be faulty.	Initialize the unit or conduct zero calibration.	18 7
	Is the oxygen concentration in the atmosphere 20% O ₂ or less, or 22% O ₂ or more?	Calibrate the span.	6
	If the symptoms do not improve even after taking the above actions, the main unit may be faulty.	Make a request for repairs.	33
The O ₂ measurement value is negative.	The zero calibration may be faulty.	Initialize the unit or conduct zero calibration.	18 7
The printer does not print.	Is the printer correctly connected?	Correctly connect the printer.	20
	Is "PRINTER" selected on the "OUT SET" screen under the "SETTING" menu?	Make sure the output setting destination is "PRINTER".	15
	If the symptoms do not improve even after taking the above actions, the main unit or printer may be faulty.	Make a request for repairs.	33



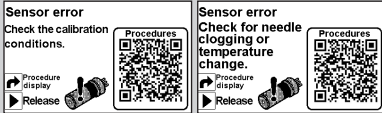

Reference: Refer to the Iijima Electronics Corporation website for information on troubleshooting, handling, and maintenance.
<https://www.ijima-e.co.jp/>

Contact the dealer from which you purchased the product if you have any questions or inquiries regarding handling.

Error Messages

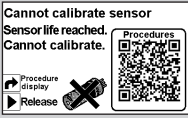
An error message may display based on the self-diagnosis conducted during use. Check the details of the displayed error, and troubleshoot with the following actions. If the symptoms do not subside, refer to the section “After Sales Service” (page 33) and contact the dealer from which you purchased the product.

Symptom	Check	Action	Reference page
Sensor error This error occurs in the following cases: <ul style="list-style-type: none"> When the oxygen sensor output is unstable during span or zero calibration. When the oxygen sensor output is unstable during measurement. When the ambient temperature changes drastically. When the needle, filter, or tube is loose or damaged. When the oxygen sensor membrane is damaged. 	Is the oxygen sensor correctly mounted? ----- Is the O-ring for the housing deviated?	Align the ▲ mark on the probe (blue) with the ▲ mark on the housing (red). ----- Firmly mount the O-ring for the housing in the groove.	21
	Has water or foreign matter gotten between the oxygen sensor and housing?	Remove the oxygen sensor and clean the inside of the housing. Lightly wipe the metal mesh at the center of the oxygen sensor surface with tissue paper, etc., to remove any moisture or foreign matter. Replace the needle, membrane filter, check valve, and sampling tube with new parts.	21 22
	Is the connection of the needle, membrane filter, check valve, or sampling tube loose?	Securely tighten the connection for the needle, membrane filter, check valve, or sampling tube.	21 22
	Is the needle, membrane filter, check valve, or sampling tube clogged?	Check for clogging. If clogged, unplug the part or replace it with a new part. If the symptoms do not improve, make a request for repairs.	16 21,22 33
	Is the needle, membrane filter, check valve, or sampling tube damaged?	Replace the damaged part with a new part.	21 22
	Are there any factors that could cause the measurement environment temperature to change drastically? (Close to the air conditioning blow-off port, heating appliance, etc.)	Calibrate the span in a room with little temperature change, where it is not affected by air conditioning.	6
	If the symptoms are not resolved even after taking the above actions and confirming the calibration conditions, the oxygen sensor membrane may be damaged.	Replace the oxygen sensor with a new part. (Contact the dealer from which you purchased the product if the warranty is still valid.)	21 33
	If the symptoms do not improve even after replacing the oxygen sensor, the main unit may be faulty.	Make a request for repairs.	33
Sensor warranty term (O₂) This message shows the remaining number of days in the oxygen sensor warranty term. 	Check the remaining number of days in the warranty term.	The following message “Sensor warranty expired” appears when the warranty has expired. Prepare to replace the sensor as soon as possible.	
Sensor warranty expired This message indicates that the oxygen sensor warranty has expired. 	The oxygen sensor cannot be used for more than one year.	The oxygen sensor can be used past the warranty term. However, the following “Sensor life reached” error will occur in time, and calibration and measurements will not be possible. Prepare to replace the sensor as soon as possible.	
Sensor life prediction This message indicates that the oxygen sensor life is almost reached. 	The oxygen sensor's service life is approaching.	The sensor can be used for a while after the message appears, but the oxygen sensor output has dropped, so calibration will not be possible in time. Prepare a new oxygen sensor and replace.	21

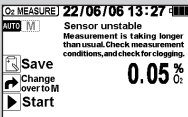
Symptom	Check	Action	Reference page
Sensor life reached This message indicates that the oxygen sensor life has been reached. 	The oxygen sensor has reached its service life.	Measurements are possible, but the oxygen sensor output has dropped, so calibration will not be possible. After a short time, the "Cannot use sensor" error message will appear, and measurements will not be possible. Prepare a new oxygen sensor and replace.	21
Cannot calibrate sensor This message indicates that the calibration cannot be performed because the oxygen sensor life has been reached. 	The oxygen sensor has reached its service life.	Measurements are possible for a while, but the oxygen sensor output has dropped, so calibration will not be possible. Measurements will also be disabled in time, so replace with a new oxygen sensor.	21
Cannot use sensor (O₂) This message indicates that the oxygen sensor cannot be used because it has reached its service life. 	The oxygen sensor has reached its service life.	The oxygen sensor cannot be used because the output has dropped and the sensor has reached its service life. Replace with a new oxygen sensor.	21
Battery life reached This message indicates that the batteries have reached their life. 	The batteries have reached their service life.	Replace the batteries with new ones.	1
Main unit fault This message indicates that the internal IC is faulty or there is noise. 	Does the error message appear even after the power is turned ON and OFF two or three times?	Make a request for repairs.	33
	Is the battery holder rusty?		33
Sensor unstable This message indicates that the measurement took longer than usual (90 to 120 seconds or more). The following causes can be considered. <ul style="list-style-type: none"> • When the ambient temperature changes drastically. • The needle, filter, or tube is loose or damaged. • When the oxygen sensor membrane is damaged. 	Is the connection of the needle, membrane filter, check valve, or sampling tube loose?	Securely tighten the connection for the needle, membrane filter, check valve, or sampling tube.	21 22
	Is the needle, membrane filter, check valve, or sampling tube clogged?	Check for clogging. If clogged, unclog the part or replace it with a new part.	16 21,22 33
	Is the needle, membrane filter, check valve, or sampling tube damaged?	Replace the damaged part with a new part.	21 22
	Is the oxygen sensor correctly mounted? ----- Is the O-ring for the housing deviated?	Align the ▲ mark on the probe (blue) with the ▲ mark on the housing (red). ----- Firmly mount the O-ring for the housing in the groove.	21

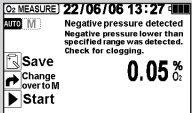
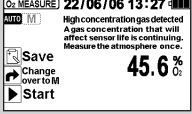
Symptom	Check	Action	Reference page
	Has water or foreign matter gotten between the oxygen sensor and housing?	Remove the oxygen sensor and clean the inside of the housing. Lightly wipe the metal mesh at the center of the oxygen sensor surface with tissue paper, etc., to remove any moisture or foreign matter. Replace the needle, membrane filter, check valve, and sampling tube with new parts.	21 22
	Are there any factors that could cause the measurement environment temperature to change drastically? (Close to the air conditioning blow-off port, heating appliance, etc.)	Take the measurement in a room with little temperature change, where it is not affected by air conditioning.	
	If the symptoms are not resolved even after taking the above actions and confirming the calibration conditions, the oxygen sensor membrane may be damaged.	Replace the oxygen sensor with a new part. (Contact the dealer from which you purchased the product if the warranty is still valid.)	21 33
Printer error 	Is the printer or personal computer connected correctly?	Correctly connect the printer.	20
	Are the communication settings with the printer or personal computer correct?	Reset the communication settings. (Refer to the Operation manual enclosed with the PACK MASTER or printer.)	20
Negative pressure detected This message indicates that a negative pressure lower than -40kPa was detected. 	Is the check valve mounted in the correct direction?	Re-mount in the correct direction so that the narrow side of the check valve faces the sampling tube.	22
	Is the needle, membrane filter, check valve, or sampling tube clogged?	Check for clogging. If clogged, unclog the part or replace it with a new part. If the symptoms do not improve, make a request for repairs.	16 21 22 33
	Has water or foreign matter gotten between the oxygen sensor and housing?	Remove the oxygen sensor and clean the inside of the housing. Lightly wipe the metal mesh at the center of the oxygen sensor surface with tissue paper, etc., to remove any moisture or foreign matter. Replace the needle, membrane filter, check valve, and sampling tube with new parts. If the symptoms do not improve, replace the oxygen sensor with a new part. (Contact the dealer from which you purchased the product if the warranty is still valid.)	21 22 33
	If the symptoms are not resolved even after taking the above actions and confirming the calibration conditions, there may be a clog inside the main unit.	Make a request for repairs.	33
High concentration gas detected This message indicates that high concentration gas was detected at 40%O ₂ or higher for two minutes or more. 	Was a high concentration gas sample just measured?	If the sensor is exposed to high concentration gas, the life could be shortened. When halting measurements for two minutes or longer, measure the atmosphere once to lower the concentration	
	If the symptoms are not resolved even after taking the above actions, the main unit or sensor may be faulty.	Make a request for repairs.	33

Product Specifications

Item		Specifications
Product name/model		Residual Oxygen Meter "PACK MASTER®" / RO-105S
Oxygen sensor	Model	WAGNIT®/WA-SGF2 (One year warranty)
	Measurement method	Membrane type galvanic cell
Display method		Monochrome TFT LCD display
Measurement items • Measurement range	O ₂	Oxygen concentration: 0.00 to 9.99% O ₂ , 10.0 to 85.0% O ₂ automatic range changeover Gas replacement rate: 0.0 to 100.0%
	DO*1	0.00 to 9.99mg/L, 10.0 to 20.0mg/L automatic range changeover (Restricted within the measurement range for DO saturation rate) Saturation rate: 0.0 to 200.0% Water temperature: 0.0 to 40.0°C
Repeatability (Following our measurement conditions at shipment)	O ₂	0.00 to 0.99%O ₂ : ±0.03% O ₂ 1.00 to 9.99%O ₂ : ±0.09% O ₂ 10.0 to 25.0%O ₂ : ±0.2% O ₂ 25.1 to 85.0%O ₂ : ±2.0% O ₂
Measurement method		One-touch sampling
Required gas volume		6mL*2
Measurement time		6 seconds*2
Calibration method (O ₂)		Select "CAL" from the menu and press the START key to calibrate.
Memory function		Up to 300 measurements can be saved. The history can be displayed on the screen.
External output		External connection possible with an RS-232C cable (printer, personal computer)
Other functions		<ul style="list-style-type: none"> • Automatic stability decision function (With display function using progress status bar) • Self-diagnosis function (Error message displayed when sensor life is reached or output error occurs, etc.) • Sensor warranty term notification function (oxygen sensor only) • Clogging detection function • Japanese/English selection function • Timezone selection function • Guidance display function • Initialization function • Time display function
Operating temperature range		5 to 40°C (with no dew condensation)
Power supply		AA alkaline batteries or nickel-metal hydride batteries (rechargeable) x 4 batteries, or AC adapter (100 VAC)
Main unit dimensions		93 (W) x 155 (D) x 125 (H) mm (excluding protrusions)
Weight		Approx. 620g (including batteries)

*1 In order to measure DO, the DO Measuring Device (model: MA-300, optional accessory) is required.

*2 When measuring multiple samples successively in the Auto mode.

- "PACK MASTER®" is a registered trademark of the Iijima Electronics Corporation product.
- "WAGNIT®" is a registered trademark of the Iijima Electronics Corporation oxygen sensor.
- These specifications are subject to change without notice for product improvement.

After Sales Service [When requesting repairs]

Please contact the dealer from which you purchased the product to inquire about repairs and inspections when using the instrument in a country or region other than Japan.

(When using the instrument in Japan, please contact your dealer or Iijima Electronics Corporation directly to inquire about repairs and inspections.)

When making an actual request for repairs, please indicate the situation of the fault (displayed details or values, frequency of occurrence, conditions of occurrence, etc.) in as much detail as possible.

Warranty

This product has been subjected to various tests based on the Iijima Electronics Corporation specifications and is guaranteed to have a performance that meets those standards.

•Name of product under warranty

Residual Oxygen Meter "PACK MASTER®" (model RO-105S)
oxygen sensor "WAGNIT®" (model WA-SGF2)

•Warranty term

PACK MASTER: Two years from the date of shipment from Iijima Electronics Corporation
Oxygen sensor: One year from the date of the sensor package is opened

Note that the maximum warranty term is two years from the date of shipment from Iijima Electronics Corporation, including the storage term* and warranty term.

* "One year storage" is only in the case of using in Japan.

IJIMA Iijima Electronics Corporation

1-1, Ishida, Toyooka-cho, Gamagori-shi, Aichi 443-0011 JAPAN
Telephone: +81-533-67-2827 Facsimile: +81-533-69-6814

1. If a failure occurs within the warranty term under normal conditions of use following the Operation manual and accompanying precautions, the product will be repaired free of charge.

Note that the accessories and consumable parts (excluding the oxygen sensor "WAGNIT®") are excluded from the warranty.

* Parts excluded from the warranty: AC adapter, needle (vertical slot type, horizontal slot type), membrane filter, check valve, sampling tube with fitting, sampling pump, filter, adhesive rubber, maintenance kit, AA alkaline batteries

For details on the oxygen sensor (WAGNIT®), refer to the separately enclosed "Oxygen sensor "WAGNIT®" model: WA-SGF2 Warranty".

2. The following cases will be excluded even during the warranty term.
 - (1) Failure or damage due to improper use *1 or repair or modification by a party other than Iijima Electronics Corporation.
*1 Conducting measurements without membrane filter mounted, etc.
 - (2) Failure or damage caused by dropping, etc.
 - (3) When the actual product cannot be confirmed because it is lost, etc.
 - (4) Deformation or damage caused by chemicals such as organic solvents.
 - (5) Failure or damage caused by fire, earthquake, water damage, lightning, or other natural disasters.
 - (6) When the abnormality cannot be confirmed.
 - (7) When this warranty is not presented.
3. This warranty does not cover secondary damages (such as damage to devices or equipment, lost opportunities, lost profits, etc.) or any damages that may result from the failure of the product covered by this warranty.

 Iijima Electronics Corporation

1-1, Ishida, Toyooka-cho, Gamagori-shi, Aichi 443-0011 JAPAN

Telephone: +81-533-67-2827

Facsimile: +81-533-69-6814

<https://www.iijima-e.co.jp/>