

□□□□□□□□□□□□□□□□□□□□

Opener / KO-X1 Operation Manual

□□□□□□□□□□□□□□□□□□□□

Thank you for purchasing the Iijima Opener “model KO-X1”.





The opener KO-X1 is a hole opening tool designed mainly for plastic caps used on plastic bottles. Refrain from using this tool to open holes in other caps made of hard materials, etc., as there is a risk of faults. Do not apply force with other tools when opening holes. Doing so could result in faults.

Always read and fully understand this manual before starting to ensure correct and safe use. Keep this manual near the tool for quick reference at any time.

1. Confirmation of Package Contents

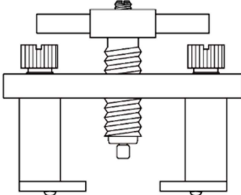
When unpacking the KO-X1 Opener, confirm that the following items are included and that the contents have not been damaged. If any parts are missing or damaged, contact the dealer which you purchased the product.

Package contents

	Description	Quantity
1	Opener (model:KO-X1) 	1
2	Needle (ø0.8x74 mm) The 74 mm long needle is dedicated for the KO-X1. Specify "Needle (model: T-X1, 5-pc. set)" when ordering additional needles. 	1 pc.
3	Rubber stopper 1 Specify "Rubber Stopper 1 (model: M-10, 30-pc. set)" when ordering additional rubber stoppers. 	10 pcs.
4	Rubber stopper 2 Specify "Rubber Stopper 2 (model: M-20, 30-pc. set)" when ordering additional rubber stoppers. 	10 pcs.
5	Rubber packing (ø10) 	2 pcs.
6	Operation manual (this document)	1

2. Names of each part

The opener is shipped with all parts set. Refer to the following drawing when replacing or servicing parts.

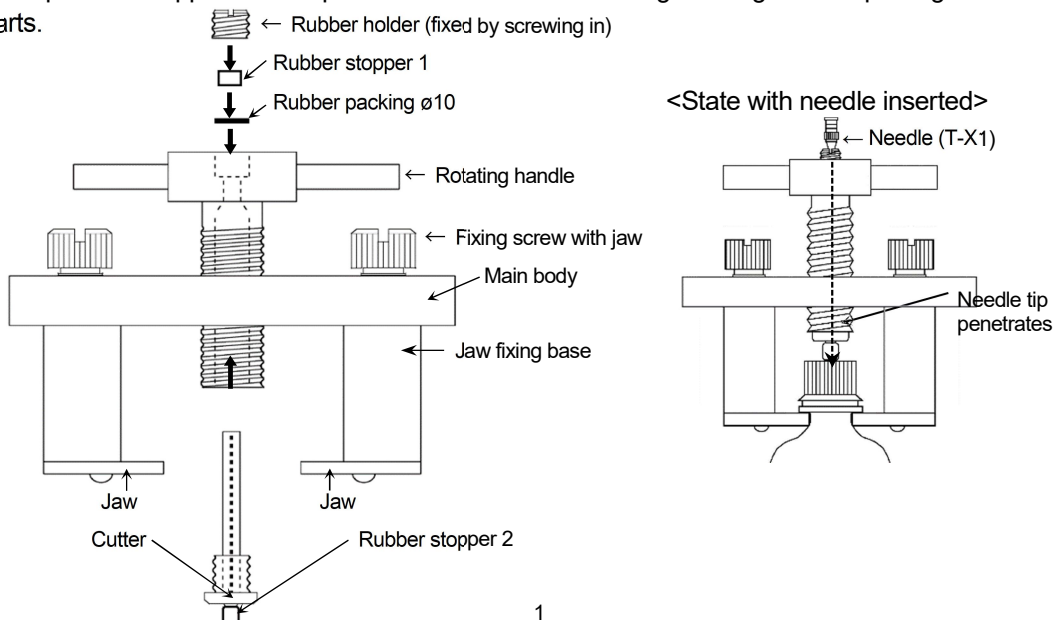

3. Preparing for use

Make sure the sample bottle meets the following conditions.

<Usage conditions>

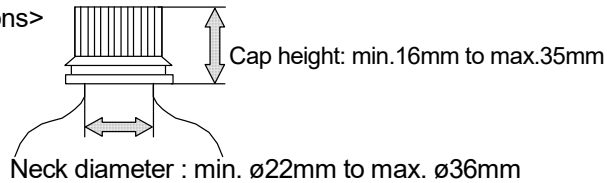

Step 1. Remove the standard needle attached with the oxygen meter.

- For oxygen meter models RO-105 series, the standard needle is model: NN-2116R.
- For oxygen meter models RO-103 series, the standard needle is model: NN-2138S.



Note

When removing the needle, do not remove the accessories, such as the membrane filter or check valve. Proper measurements may not be possible if these parts are removed.

Step 2. Attach the needle dedicated for the KO-X1.



Warning

Take care not to stab the human body with the needle. There is a risk of blindness, puncture wounds, or cuts.

Step 3. Prepare the oxygen meter with state and setting so that it is ready for measurement.

(Refer to the operation manual enclosed with the oxygen meter for details.)

4. Usage methods

Step 1. Grip the neck of the measurement sample, such as the plastic bottle, with the jaws on either side.

Turn the fixing screws and fix the jaw fixing base so that the jaws tightly grip the sample's neck and do not move.

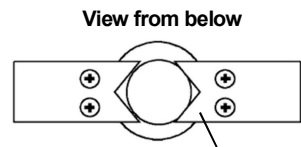

Grip the neck with the jaws on either side

Step 2. Hold the jaw fixing base on either side with a hand to prevent movement, and then turn the rotating handle clockwise.

Turn the rotating handle two turns from where the cutter contacts the cap.

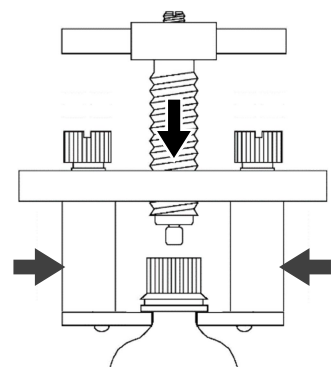

Caution

Do not turn the rotating handle further once the hole is opened. Rotating it further will put an excessive load on the threads and can result in damage.

Step 3. Insert the needle into the hole on the rubber stopper.

The tip of the needle will reach the headspace of the sample in the plastic bottle, etc.

Step 4. Operate the oxygen meter to sample and measure the sample gas.

For details, refer to the measurement methods described in the operation manual enclosed with the oxygen meter.

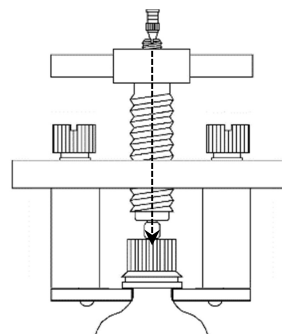

- If there is less than 10mL of sample gas, or if the sample cannot be used the KO-X1 because of the shapes and materials, measure with the Gas Sampling Glass Tube (model: GS-2) option (sold separately).
- A measurement can be taken even if the inside of the sample is pressurized. However, if the inner pressure of the package is higher than +40 kPa, the components could break when the needle is pierced, or a correct measurement value may not be obtained.



Note

<Using oxygen meter RO-105 series >

Do not use the KO-X1 Oponer when measuring a sample pressurized above +40 kPa. Instead, measure with the Gass Sampling Glass Tube (model: GS-2) option (sold separately).

<Using oxygen meter RO-103S>

Measure with the Compression and Decompression Sampler (model: S-2) option. In this case, repeat the suction operation two to three times to sample the gas and read the value when the sample gas is stabilized.

- If there are any concerning symptoms, refer to the symptoms and actions explained in the Troubleshooting Section of the operation manual enclosed with the oxygen meter.



Note

Replace rubber stopper 1 and rubber stopper 2 with new parts if any degradation is observed.

Please contact the dealer from which you purchased the product if you have any questions or inquiries regarding handling, repairs, or inspections.

You can also watch the video on how to handle the product. <https://www.ijjima-e.co.jp/en/video.html>

<Video page>



IJJIMA Ijjima Electronics Corporation

1-1, Ishida, Toyooka-cho, Gamagori-shi, Aichi 443-0011 JAPAN

Telephone: +81-533-67-2827 Facsimile: +81-533-69-6814 E-mail: eigy@ijjima-e.co.jp

<https://www.ijjima-e.co.jp/>