

GENERAL CATALOG 2023



TORQUE WRENCH

AND ANALYZER

<http://www.bestool-kanon.co.jp>



NAKAMURA MFG.CO.,LTD.
TSURU FACTORY



ISO 9001
JQA-2434



ISO 14001
JQA-EM1367

BESTOOL-KANON

Exploring the frontiers of higher accuracy and reliability.

Every single fastener fulfills an important function maintaining the life of every product. In the transportation or chemical industries, if a fastener loosens from improper tightening, it might cause a serious disaster costing human life. We focus our techniques and wisdom, accumulated over many years, on preventing such occurrences.

Tightening only by hand will cause unexpected disaster. For example,

Traffic accidents

Improper wheel nut tightening resulting in wheels coming off.

Construction accidents

Improper tightening of structural joints resulting in collapsing scaffolding or buildings.

Explosions

Improperly tightened underground gas line joints resulting in leakage and explosion.

Chemical accidents

In chemical plants, improperly tightened joints can release toxic substances.

Torque tools play an important role in preventing such incidents.

Torque tools tighten joints uniformly with adequate force.

In particular they serve:

1. To prevent under-or-over-tightening.
2. To tighten multiple bolts uniformly.
3. To adequately generate the clamping force required for bolted joints.

BESTOOL-KANON

NOTE: Can be calibrated to : Inch pounds, Foot pounds, Newton meters.

PAGE 3

QLK

ADJUSTABLE, RATCHET TORQUE WRENCHES



PAGE 4

GLK/BLK

ADJUSTABLE, RATCHET TORQUE WRENCHES WITH RUBBER GRIP



PAGE 5

QSPK QSPKH,QSPK-A

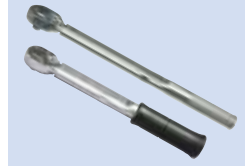

PAGE 6

SPCK/SPCKH,SPCKA

PRE-SET, REPLACEABLE HEAD TORQUE WRENCHES

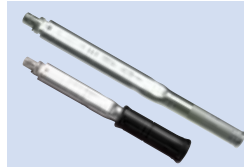

PAGE 7

LCK/GCK

ADJUSTABLE, REPLACEABLE HEAD TORQUE WRENCHES

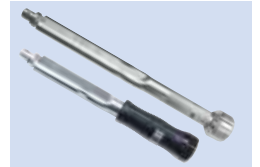

PAGE 8

BCK

ADJUSTABLE, REPLACEABLE HEAD TORQUE WRENCHES WITH RUBBER GRIP



PAGE 8~10

HEADS

OPTIONAL REPLACEABLE HEADS



PAGE 11

SPK

PRE-SET TORQUE WRENCHES

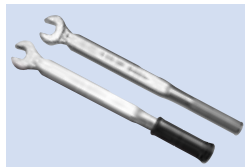

PAGE 12

RSPK

PRE-SET, RING TORQUE WRENCHES

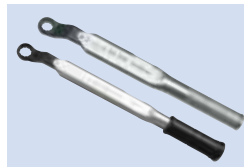

PAGE 13

QLK-LR/ HYK

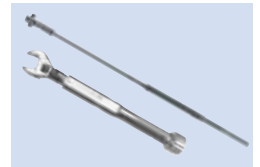

PAGE 14

MQLK MQLK-E

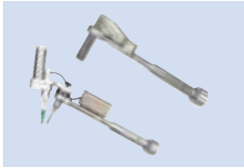

PAGE 15

TCSK-99MA SWPM Series



PAGE 16

ZLK/FK

INDICATOR PLATE TORQUE WRENCHES

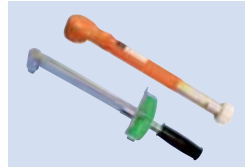

PAGE 17

TOK-G

DIAL INDICATOR TORQUE WRENCHES

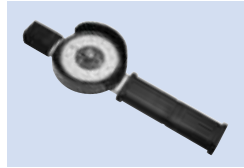

PAGE 18

DLT-N

KANON DIGITAL TORQUE WRENCH

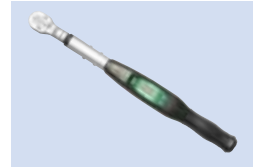

PAGE 19

DTC-REV

DATA OUTPUT DIGITAL TORQUE WRENCHES

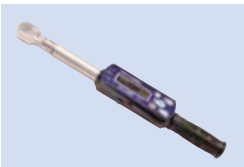

PAGE 20

DTC-REV-A DTC-REV-UW

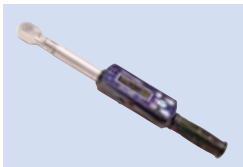

PAGE 21

DTC-REV

DIGITAL TORQUE WRENCH WITH CONNECTED DISPLAY



PAGE 21

DTDK-REV

DIGITAL TORQUE DRIVER WITH CONNECTED DISPLAY



PAGE 22

LTDK

CLUTCH RELEASE TORQUE SCREW DRIVERS



PAGE 23

STDK

PRE-SET TORQUE DRIVERS



PAGE 24

DPSK

DIAL GAUGE TORQUE DRIVERS

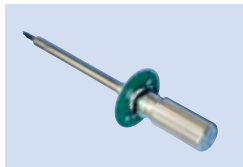

PAGE 25

SGK

TORQUE GAUGES



PAGE 26

KDTA-GT-UC

DIGITAL TORQUE ANALYZERS



PAGE 27

KDTA-GTH-UC

LARGE DIGITAL TORQUE ANALYZERS



PAGE 28

KDTA-GTS-UC

DIGITAL TORQUE ANALYZERS



PAGE 28~29

DRT

KANON TORQUE MEASUREMENT MULTI-INDICATOR



PAGE 30

KDTA-DH

DIGITAL TORQUE ANALYZERS FOR TORQUE DRIVERS



PAGE 30

KDTA-D

DIGITAL TORQUE ANALYZERS FOR ELECTRIC DRIVERS



PAGE 31

TK

TENSION GAUGES



QLK ADJUSTABLE, RATCHET TORQUE WRENCHES

Freely set torque values within the capacity range. Replaceable socket, ratchet wrenches.

FEATURES

- The ratchet improves efficiency. These wrenches are well suited for repetitive work.
- By replacing the sockets, various sizes of fasteners can be tightened within the tool's capacity range.
- By reversing the ratchet, the wrench can be used to loosen fasteners counter-clockwise.
- Tightening to a torque setting can only be done clockwise.
- Accuracy : ±3% of indicated value over the full range.



ADJUSTING THE TORQUE SETTING

◆ 30QLK~5600QLK

- (1) Loosen the lock screw. (See Fig.1)
- (2) Turn the sub-scale and adjust to a torque value (the main scale plus the sub-scale)(See Fig.2)
- (3) Tighten the lock screw. (If the lock screw hits the pin before completely tightening, then change the position of the pin)

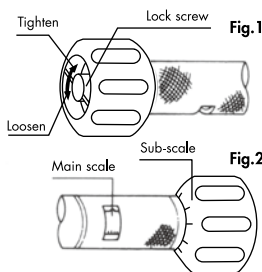

◆ 7000QLK~21000QLK-8

- (1) When applicable, mount the extension bar snugly all the way onto the body of the wrench.
- (2) With the extension bar mounted (See Fig.3), insert the hexagonal side of the adjusting box wrench.
- Without the extension bar (See Fig.4), insert the hexagonal side of the adjusting box wrench into the body.
- (3) Turn the adjusting box wrench to set the torque value. (the main scale plus the sub-scale)

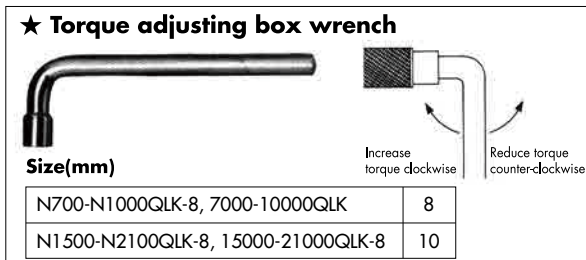
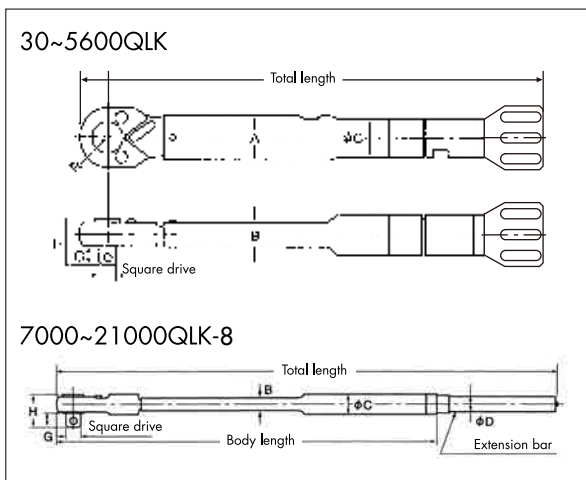
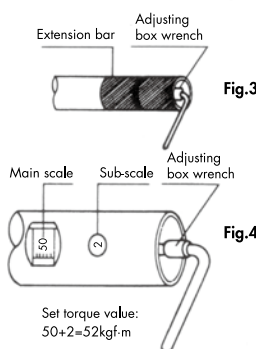

Model (kgf·cm/kgf·m)	Range	Increment	Old Model (cN·m/N·m)	New Model (cN·m/N·m)	Range	Increment	Model (lbf·in)	Range	Increment	Square drive	Total length	Dimensions (mm)								Weight	Standard Accessory	
												Head				Body						
	kgf·cm/kgf·m	kgf·cm/kgf·m			cN·m/N·m	cN·m/N·m		lbf·in	lbf·in	mm	mm	H	G	R	A	B	C	D	Body length	kg		
30QLK	10~30	0.5	N30QLK	CN300QLK	100~300	5				6.35 (1/4")	187	18.8	7.5	12	18.2	9.6	15			0.19		
60QLK	20~60	1	N60QLK	N6QLK	2~6	0.1																
120QLK	40~120	2	N120QLK	N12QLK	4~12	0.2	PI 120QLK	40~120	2													
250QLK	50~250	2	N250QLK	N25QLK	5~25	0.2	PI 230QLK	70~230	2	9.53 (3/8")	232	25	11	15.5	16	25	11.4	20		0.28		
500QLK	100~500	5	N500QLK	N50QLK	10~50	0.5	PI 450QLK	100~450	5		257									0.47		
900QLK	200~900	10	N900QLK	N90QLK	20~90	1														0.81		
1000QLK	200~1000	10	N1000QLK	N100QLK	20~100	1	PI 1000QLK	200~1000	10		359	31	14	19.7	27.5	12.4	21.7			0.86		
1400QLK	400~1400	10	N1400QLK	N140QLK	40~140	1				12.7 (1/2")	399											
1800QLK	400~1800	20	N1800QLK	N180QLK	40~180	2																
2000QLK	400~2000	20	N2000QLK	N200QLK	40~200	2	PI 2000QLK	400~2000	20		491	33	15.4	23	34						1.5	
2800QLK	400~2800	20	N2800QLK	N280QLK	40~280	2															1.95	
3600QLK	800~3600	20	N3600QLK	N360QLK	80~360	2															2.1	
4200QLK	6~42	0.2	N4200QLK	N420QLK	60~420	2				19.05 (3/4")	965	42.7	20	27.5	38	16	30				3.3	
5600QLK	8~56	0.3	N5600QLK	N560QLK	80~560	3					1,195										5	
7000QLK	10~70	0.5	N7000QLK	N700QLK	100~700	5					1,314	49.5		34	43.5	18	34				8.5	
8500QLK	10~85	0.5	N8500QLK	N850QLK	100~850	5					1,388				46	19.2	35.4	27.2	990		6.2	
10000QLK	10~100	0.5	N10000QLK	N1000QLK-8	100~1000	5					1,538	58		38	54	23	42.7	31.8	1,105		8.8	
15000QLK	20~150	1	N15000QLK	N1500QLK	200~1500	10					1,844											14
21000QLK-8	70~210	1	N21000QLK	N2100QLK-8	700~2100	10					2,064	61		43.5	66	26	51	40	1,144		19.5	

* is the new model that is applied from 1st January, 2016.

GLK

ADJUSTABLE, RATCHET TORQUE WRENCHES WITH RUBBER GRIP

Freely set torque values within the capacity range. Replaceable socket, ratchet wrenches.

FEATURES

- The ratchet improves efficiency. These wrenches are well suited for repetitive work.
- By replacing the sockets, various sizes of fasteners can be tightened within the tool's capacity range.
- By reversing the ratchet, the wrench can be used to loosen fasteners counter-clockwise.
- Tightening to a torque setting can only be done clockwise.
- Accuracy : $\pm 3\%$ of indicated value over the full range.



60~2000GLK

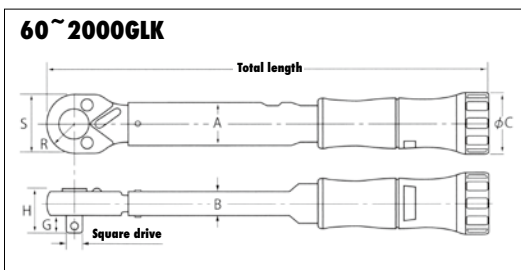

Model (kgf·cm)	Range	Increment	Model (N·m)	Range	Increment	Square drive	Total length	Dimensions (mm)							Weight
								Head				Body			
	kgf·cm	kgf·cm		N·m	N·m	mm	mm	H	G	S	R	A	B	φ C	kg
60GLK	20~60	1	N6GLK	2~6	0.1	6.35 (1/4")	187	18.8	7.5	24	12	18.2	9.6	29	0.2
120GLK	40~120	2	N12GLK	4~12	0.2										0.28
250GLK	50~250	2	N25GLK	5~25	0.2	9.53 (3/8")	233	25	11	31	15.5				0.47
500GLK	100~500	5	N50GLK	10~50	0.5		255			32	16	25	11.4	35	0.8
1000GLK	200~1000	10	N100GLK	20~100	1		355	31	14	39.4	19.7	27.5	12.4	38	0.87
1400GLK	400~1400	10	N140GLK	40~140	1	12.7 (1/2")	395								1.48
2000GLK	400~2000	20	N200GLK	40~200	2		480	33	15.4	46	23	34	15.4	40	1.48

BLK

ADJUSTABLE BY HEX WRENCH, RATCHET TORQUE WRENCHES WITH RUBBER GRIP

Freely set torque values within the capacity range. Replaceable socket, ratchet wrenches.

FEATURES

- Adjusted setting torque value by hex wrench.
- The ratchet improves efficiency. These wrenches are well suited for repetitive work.
- By replacing the sockets, various sizes of fasteners can be tightened within the tool's capacity range.
- By reversing the ratchet, the wrench can be used to loosen fasteners counter-clockwise.
- Tightening to a torque setting can only be done clockwise.
- Accuracy : $\pm 3\%$ of indicated value over the full range.



250~1400BLK

*Hex wrench is not included

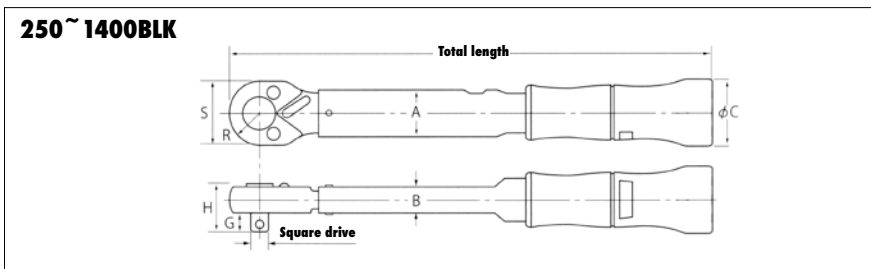

Hex wrench
2.5mm for 250, N25BLK

Hex wrench
4mm for N50, N100, N140BLK
500, 1000, 1400BLK

Model (kgf·cm)	Range	Increment	Model (N·m)	Range	Increment	Square drive	Total length	Dimensions (mm)						Weight
								Head			Body			
	kgf·cm	kgf·cm		N·m	N·m	mm	mm	H	G	R	A	B	C	kg
250BLK	50~250	2	N25BLK	5~25	0.2	9.53(3/8")	229	25	11	15.5	18.2	9.6	30	0.26
500BLK	100~500	5	N50BLK	10~50	0.5		247							16
1000BLK	200~1000	10	N100BLK	20~100	1	12.7(1/2")	346	31	14	19.7	27.5	12.4	36	0.78
1400BLK	200~1400	10	N140BLK	20~140	1		386							

QSPK

PRE-SET, RATCHET TORQUE WRENCHES, METAL HANDLE

Pre-set torque value. Improved work efficiency with ratchet square drive.

FEATURES

- The ratchet drive enables quickly tightening fasteners to the preset torque. Suitable for repetitive jobs.
- The wrench's inner mechanism automatically resets itself for the the next job after disengaging from a tightened joint.
- Accuracy : ±3% of pre-set value.

EXAMPLE OF ORDER

Model Pre-set Value
 | |
 N100QSPK × 72N·m

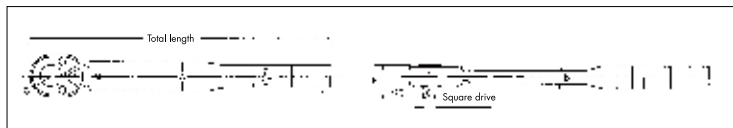

QSPK (Metal Handle)

Model (kgf·cm)	Range kgf·cm	Old Model (N·m)	New Model (N·m)	Range N·m	Model (lbf·in/lbf·ft)	Range lbf·in/lbf·ft	Square drive mm	Total length mm	Dimensions (mm)						Weight kg	
									Head			Body				
									H	G	R	A	B	C		
60QSPK	20~60	N60QSPK	N6QSPK	2~6	PI 60QSPK	20~60 lbf·in	6.35 (1/4")	174	19.5	7.5	12.5	18.2	9.6	15	0.17	
120QSPK	40~120	N120QSPK	N12QSPK	4~12	PI 120QSPK	40~120 //		220								
250QSPK	50~250	N250QSPK	N25QSPK	5~25	PI 230QSPK	70~230 //	9.53 (3/8")	240	25	12	16	25	11.4	20	0.25	
500QSPK	100~500	N500QSPK	N50QSPK	10~50	PI 450QSPK	100~450 //		340								
1000QSPK	200~1000	N1000QSPK	N100QSPK	20~100	PI 900QSPK	200~900 //	12.7 (1/2")	380	31	14	19.7	27.5	12.4	21.7	0.64	
1400QSPK	400~1400	N1400QSPK	N140QSPK	40~140	PI 1400QSPK	400~1400 //		463.5								
2000QSPK	400~2000	N2000QSPK	N200QSPK	40~200	PI 1800QSPK	400~1800 //	19.05 (3/4")	664	42	20	23	34	15.4	27.2	1.35	
2800QSPK	600~2800	N2800QSPK	N280QSPK	60~280	PI 2800QSPK	600~2800 //		935								
4200QSPK	600~4200	N4200QSPK	N420QSPK	60~420	PF 300QSPK	50~300 lbf·ft									3.5	

RE-SETTING THE PRE-SET TORQUE

(SPK · RSPK · QSPK · SPCK · TYPES)

- (1) Remove the screw cap with a slot drive screw driver.
- (2) Loosen the setting screw with a hex wrench.
- (3) Rotate the adjusting tool to clockwise to increase or counterclockwise to reduce torque.
 Check the set torque value with torque analyzer.
- (4) Tighten the setting screw with a hex wrench.
- (5) Screw on the screws cap and tighten it.

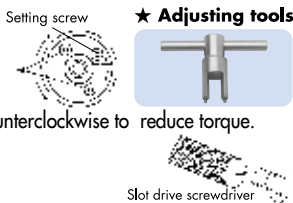

Model	Applicable Torque wrench Tools
Adjusting Tool No.1	(N)3,8,19SPK(H),N3,5,9,21RSPK(H),N6,12,25QSPK(H),30,80,190SPK(H),RSPK(H),60,120,250QSPK(H)
Adjusting Tool No.2	N38,67SPK(H),N42,73RSPK(H),N50,100,140QSPK(H),380,670SPK(H),RSPK(H),500,1000,1400QSPK(H)
Adjusting Tool No.3	N120,160,220SPK,N127,170230RSPK,N200,280QSPK,1200,1600,2200SPK,RSPK,2000,2800QSPK
Adjusting Tool No.4	N310SPK,N320RSPK,N420QSPK,3100SPK,RSPK,4200QSPK
Adjusting Tool No.5	N420SPK,N430RSPK,4200SPK,RSPK

* Adjusting tool is option.

QSPKH, QSPKA

PRE-SET, RATCHET TORQUE WRENCHES WITH RUBBER GRIP

Pre-set torque value. Improved work efficiency with ratchet square drive.

FEATURES

- The ratchet drive enables quickly tightening fasteners to the preset torque. Suitable for repetitive jobs.
- The wrench's inner mechanism automatically resets itself for the the next job after disengaging from a tightened joint.
- Accuracy : ±3% of pre-set value.
- H-type : The end cap is removed with a slotted screwdriver to adjust torque.



60~1400QSPKH, QSPKA (with Rubber Grip)
 N6~N140QSPKH, QSPKA (with Rubber Grip)

Model (kgf·cm)	Range kgf·cm	Old Model (N·m)	New Model (N·m)	Range N·m	Square drive mm	Total length mm	Dimensions (mm)						Weight kg	
							Head			Body				
							H	G	R	A	B	C		
60QSPKH	20~60	N60QSPKH	N6QSPKH	2~6	6.35 (1/4")	174	19.5	7.5	12.5	18.2	9.6	26.5	0.19	
120QSPKH	40~120	N120QSPKH	N12QSPKH	4~12		220								
250QSPKH	50~250	N250QSPKH	N25QSPKH	5~25	9.53 (3/8")	240	25	12	16	25	11.4	32.7	0.27	
500QSPKH	100~500	N500QSPKH	N50QSPKH	10~50		340								
1000QSPKH	200~1000	N1000QSPKH	N100QSPKH	20~100	12.7 (1/2")	380	31	14	19.7	27.5	12.4	37	0.41	
1400QSPKH	400~1400	N1400QSPKH	N140QSPKH	40~140		463.5								

■ A-type : Adjusted setting torque value by hex wrench.

Model (kgf·cm)	Range kgf·cm	Old Model (N·m)	New Model (N·m)	Range N·m	Square drive mm	Total length mm	Dimensions (mm)						Weight kg	
							Head			Body				
							H	G	R	A	B	C		
60QSPKA	20~60	N60QSPK-A	N6QSPKA	2~6	6.35 (1/4")	174	19.5	7.5	12.5	18.2	9.6	26.5	0.19	
120QSPKA	40~120	N120QSPK-A	N12QSPKA	4~12		220								
250QSPKA	50~250	N250QSPK-A	N25QSPKA	5~25	9.53 (3/8")	240	25	12	16	25	11.4	32.7	0.27	
500QSPKA	100~500	N500QSPK-A	N50QSPKA	10~50		340								
1000QSPKA	200~1000	N1000QSPK-A	N100QSPKA	20~100	12.7 (1/2")	380	31	14	19.7	27.5	12.4	37	0.41	
1400QSPKA	400~1400	N1400QSPK-A	N140QSPKA	40~140		463.5								

Note : Use a KANON torque wrench analyzer when adjusting torque. Without the analyzer, torque cannot be adjusted.

* is the new model that is applied from 1st January, 2016.



QSPKH

* Adjusting tool is option



QSPKA

* Hex wrench is option

SPCK PRE-SET, REPLACEABLE HEAD TORQUE WRENCHES

Work at a set torque value can proceed smoothly while using various replaceable heads.

FEATURES

- Replaceable ratchet, open end wrench, ring, and hex drive heads are available.
- Pre-set torque wrench well suited for repetitive jobs at the specified torque value.
- Accuracy : $\pm 3\%$ of pre-set value

USING AN SPCK

Mount the head on the drive.

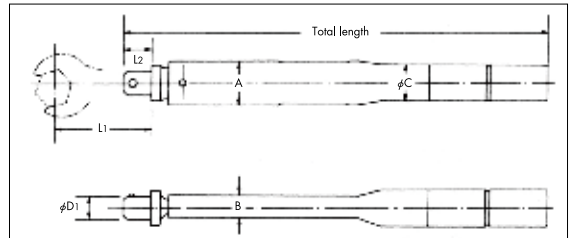

**SPCK
(Metal Handle)**

Model (kgf·cm)	Range kgf·cm	Old Model (N·m)	New Model (N·m)	Range N·m	Total length mm	Dimensions (mm)						Weight kg	Replaceable heads
						Head			Body				
						phi D1	L1	L2	A	B	phi C		
60SPCK	20~60	N60SPCK	N6SPCK	2~6	161	10	45	13	18.2	9.6	15	0.15	12QCK, 25 (QCK, SCK, RCK, HCK)
120SPCK	40~120	N120SPCK	N12SPCK	4~12								0.19	25 (QCK, SCK, RCK, HCK)
250SPCK	50~250	N250SPCK	N25SPCK	5~25	196	12	55	16	25	11.4	20	0.27	50 (QCK, SCK, RCK, HCK)
500SPCK	100~500	N500SPCK	N50SPCK	10~50	220							0.57	100 (QCK, SCK, RCK, HCK, NCK)
1000SPCK	200~1,000	N1000SPCK	N100SPCK	20~100	312	15	65	18	27.5	12.4	21.7	0.92	200 (QCK, SCK, RCK, HCK, NCK)
2000SPCK	400~2,000	N2000SPCK	N200SPCK	40~200	428	18	80	22	34	15.4	27.2	1.7	280 (QCK, SCK, RCK, HCK)
2800SPCK	600~2,800	N2800SPCK	N280SPCK	60~280	590	22	100	27	38	16	30	2.6	440 (QCK, SCK, RCK)
4400SPCK	600~4,400	N4400SPCK	N440SPCK	60~440	893							39	440 (QCK, SCK, RCK)

SPCKH, SPCKA PRE-SET, REPLACEABLE HEAD TORQUE WRENCHES WITH RUBBER GRIP

Work at a set torque value can proceed smoothly while using various replaceable heads.



**60~1000SPCKH
60~1000SPCKA
(with Rubber Grip)**

Optional Replaceable Heads (Refer to the page 10)



■ H-type : The end cap is removed with a slotted screwdriver to adjust torque.

Model (kgf·cm)	Range kgf·cm	Old Model (N·m)	New Model (N·m)	Range N·m	Total length mm	Dimensions (mm)						Weight kg	Replaceable heads
						Head			Body				
						phi D1	L1	L2	A	B	phi C		
60SPCKH	20~60	N60SPCKH	N6SPCKH	2~6	161	10	45	13	18.2	9.6	26.5	0.17	12QCK, 25 (QCK, SCK, RCK, HCK)
120SPCKH	40~120	N120SPCKH	N12SPCKH	4~12								0.21	25 (QCK, SCK, RCK, HCK)
250SPCKH	50~250	N250SPCKH	N25SPCKH	5~25	196	12	55	16	25	11.4	32.7	0.3	50 (QCK, SCK, RCK, HCK)
500SPCKH	100~500	N500SPCKH	N50SPCKH	10~50	220							0.62	100 (QCK, SCK, RCK, HCK, NCK)
1000SPCKH	200~1,000	N1000SPCKH	N100SPCKH	20~100	312	15	65	18	27.5	12.4	37	0.62	100 (QCK, SCK, RCK, HCK, NCK)

■ A-type : Adjusted setting torque value by hex wrench.

Model (kgf·cm)	Range kgf·cm	Model (N·m)	Range N·m	Total length mm	Dimensions (mm)						Weight kg	Replaceable heads	
					Head			Body					
						phi D1	L1	L2	A	B	phi C		
60SPCKA	20~60	N6SPCKA	2~6	161	10	45	13	18.2	9.6	26.5	26.5	0.17	12QCK, 25 (QCK, SCK, RCK, HCK)
120SPCKA	40~120	N12SPCKA	4~12									0.21	25 (QCK, SCK, RCK, HCK)
250SPCKA	50~250	N25SPCKA	5~25	196	12	55	16	25	11.4	32.7	32.7	0.3	50 (QCK, SCK, RCK, HCK)
500SPCKA	100~500	N50SPCKA	10~50	220								0.62	100 (QCK, SCK, RCK, HCK, NCK)
1000SPCKA	200~1,000	N100SPCKA	20~100	312	15	65	18	27.5	12.4	37	37	0.62	100 (QCK, SCK, RCK, HCK, NCK)

* is the new model that is applied from 1st January, 2016.

LCK

ADJUSTABLE, REPLACEABLE HEAD TORQUE WRENCHES

Freely replace heads according to work applications. The combination of replaceable heads and torque adjustability make this series extremely versatile.

FEATURES

- Ring, ratchet, open end wrench and hex drive heads are available.
- The torque can be set to any value within the capacity range.
- Models are available ranging from 20 kgf·cm to 15,000 kgf·cm.
- Accuracy : ±3% of indicated value over the full range



LCK

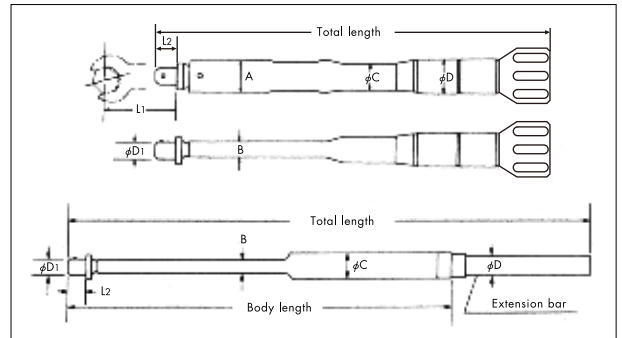

Model (kgf·cm/kgf·m)	Range kgf·cm/kgf·m	Increment kgf·cm/kgf·m	Old Model (N·m)	New Model (N·m)	Range N·m	Increment N·m	Total length mm	Dimensions (mm)							Weight kg	Replaceable heads	
								Head			Body						
								phi D1	L1	L2	A	B	C	D	Body length		
60LCK	20 ~ 60 kgf·cm	1 kgf·cm	N60LCK	N6LCK	2 ~ 6	0.1	174	10	45	13	18.2	9.6	15			0.18	12QCK, 25 (QCK, SCK, RCK, HCK)
120LCK	40 ~ 120 //	2 //	N120LCK	N12LCK	4 ~ 12	0.2										0.21	25 (QCK, SCK, RCK, HCK)
250LCK	50 ~ 250 //	2 //	N230LCK	N25LCK	5 ~ 25	0.2										208	0.38
500LCK	100 ~ 500 //	5 //	N450LCK	N50LCK	10 ~ 50	0.5	238	12	55	16	25	11.4	20			0.6	100 (QCK, SCK, RCK, HCK, NCK)
1000LCK	200 ~ 1000 //	10 //	N900LCK	N100LCK	20 ~ 100	1	331	15	65	18	27.5	12.4	21.7			1.35	200 (QCK, SCK, RCK, HCK, NCK)
2000LCK	400 ~ 2,000 //	20 //	N1800LCK	N200LCK	40 ~ 200	2	455	18	80	22	34	15.4	27.2			1.81	280 (QCK, SCK, RCK, HCK)
2800LCK	400 ~ 2,800 //	20 //	N2800LCK	N280LCK	40 ~ 280	2	653	22	100	27	39	16	30			2.8	440 (QCK, SCK, RCK)
4400LCK	6 ~ 44 kgf·m	0.2 kgf·m	N4400LCK	N440LCK	60 ~ 440	2	908	30	125	45	43.5	18	34	27.2	876	4.1	700 (QCK, SCK, RCK)
5600LCK	8 ~ 56 //	0.3 //	N5600LCK	N560LCK	80 ~ 560	3	1086									46	
7000LCK	10 ~ 70 //	0.5 //	N7000LCK	N700LCK	100 ~ 700	5	1206	34	130	47	54	23	42.7	31.8	984	7.2	1000 (QCK, SCK, RCK)
8500LCK	10 ~ 85 //	0.5 //	N8500LCK	N850LCK	100 ~ 850	5	1267									46	
10000LCK	10 ~ 100 //	0.5 //	N10000LCK	N1000LCK	100 ~ 1,000	5	1417	38	160	60	66	26	51	40	1003	13.5	2100QCK, 1500 (SCK, RCK)
15000LCK	20 ~ 150 //	1 //	N14000LCK	N1500LCK	200 ~ 1,500	10	1700										

GCK

ADJUSTABLE, REPLACEABLE HEAD TORQUE WRENCHES WITH RUBBER GRIP

Freely replace heads according to work applications. The combination of replaceable heads and torque adjustability make this series extremely versatile.

FEATURES

- Ring, ratchet, open end wrench and hex drive heads are available.
- The torque can be set to any value within the capacity range.
- Models are available ranging from 20 kgf·cm to 2,000 kgf·cm.
- Accuracy : ±3% of indicated value over the full range



GCK

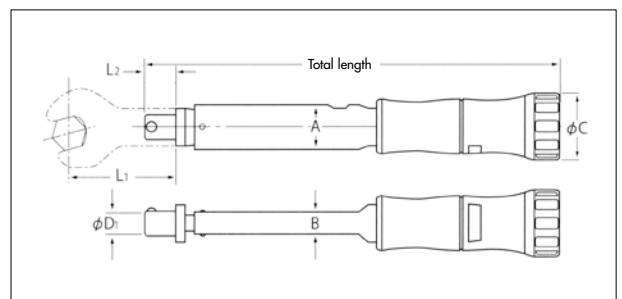

Model (kgf·cm)	Range kgf·cm	Increment kgf·cm	Model (N·m)	Range N·m	Increment N·m	Total length mm	Dimensions (mm)							Weight kg	Replaceable heads	
							Head			Body						
							phi D1	L1	L2	A	B	C				
60GCK	20 ~ 60	1	N6GCK	2 ~ 6	0.1	174	10	45	13	18.2	9.6	29			0.18	12QCK, 25 (QCK, SCK, RCK, HCK)
120GCK	40 ~ 120	2	N12GCK	4 ~ 12	0.2										0.21	25 (QCK, SCK, RCK, HCK)
250GCK	50 ~ 250	2	N25GCK	5 ~ 25	0.2										209	0.37
500GCK	100 ~ 500	5	N50GCK	10 ~ 50	0.5	235	12	55	16	25	11.4	35			0.6	100 (QCK, SCK, RCK, HCK, NCK)
1000GCK	200 ~ 1,000	10	N100GCK	20 ~ 100	1	327	15	65	18	27.5	12.4	38			0.68	100 (QCK, SCK, RCK, HCK, NCK)
1400GCK	400 ~ 1,400	10	N140GCK	40 ~ 140	1	365	18	80	22	34	15.4	40			1.3	200 (QCK, SCK, RCK, HCK, NCK)
2000GCK	400 ~ 2,000	20	N200GCK	40 ~ 200	2	480										

* is the new model that is applied from 1st January, 2016.

BCK ADJUSTABLE, REPLACEABLE HEAD TORQUE WRENCHES WITH RUBBER GRIP

Freely replace heads according to work applications. The combination of replaceable heads and torque adjustability make this series extremely versatile.

FEATURES

- Ring, ratchet, open end wrench and hex drive heads are available.
- The torque can be set to any value within the capacity range.
- Models are available ranging from 20 kgf·cm to 1,400 kgf·cm.
- Accuracy : ±3% of indicated value over the full range

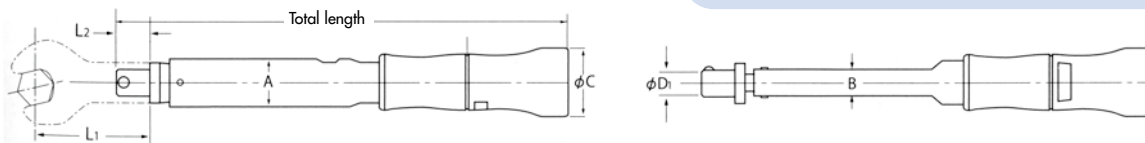

Model (kgf·cm)	Range kgf·cm	Increment kgf·cm	Model (N·m)	Range N·m	Increment N·m	Square drive mm	Total length mm	Dimensions (mm)						Weight kg
								Head			Body			
								φD1	L1	L2	A	B	φC	
250BCK	50~250	2	N25BCK	5~25	0.2	9.53(3/8")	205	10	45	13	18.2	9.6	29	0.2
500BCK	100~500	5	N50BCK	10~50	0.5	9.53(3/8")	227	12	55	16	25	11.4	35	0.35
1000BCK	200~1000	10	N100BCK	20~100	1	12.7(1/2")	318	15	65	18	27.5	12.4	38	0.58
1400BCK	200~1400	10	N140BCK	20~140	1	12.7(1/2")	356	15	65	18	27.5	12.4	38	0.66

HEADS OPTIONAL REPLACEABLE HEADS

NCK

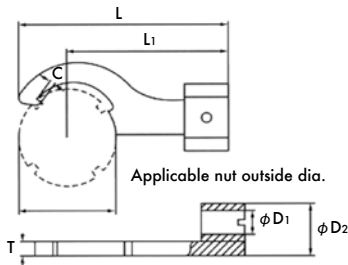

QCK-LR (Ratchet head)

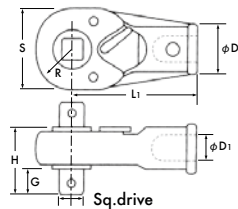

MCK (Open End head)

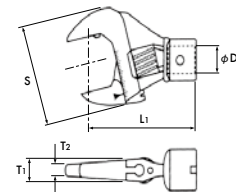

■ NCK Nut outside dia.

Unit : mm

Model	Nut outside dia.	T	C	L	L1	φD1	φD2	Applicable torque wrench
100NCK3032	30 ~ 32	5	2.3	81	65	15	28	1000LCK, N100LCK, 1000SPCK, N100SPCK, 1000, 1400GCK, N100, N140GCK, 1000BCK, 1400BCK, N100BCK, N140BCK, DTC-1000REV, DTC-N100REV, DTC-P1800REV, DLT-N100-UC
100NCK3438	34 ~ 38	6	2.5	85			29	
100NCK4042	40 ~ 42	6	2.5	88			29	
100NCK4548	45 ~ 48	6.5	2.5	91			29.5	
100NCK5055	50 ~ 55	6.5	2.5	94			29.5	
200NCK5865	58 ~ 65	7.5	3	112	80	18	33.5	2000LCK, N200LCK, 2000SPCK, N200SPCK, 2000GCK, N200GCK, DTC-2000REV, DTC-N200REV, DTC-PF100REV, DLT-N200-UC
200NCK6570	65 ~ 70	7.5	3	112			33.5	
200NCK7075	70 ~ 75	8	3.5	117			34	
200NCK8085	80 ~ 85	8.5	3.5	121			34.5	
200NCK92100	92 ~ 100	8.5	4	126			34.5	

■ QCK-LR

Unit : mm

Model	Sq. drive	S	H	G	R	L1	φD1	φD2	Applicable torque wrench
700QCK-LR	19.05 (3/4")	68	70	20	34	125	30	41	N560LCK, N700LCK
1000QCK-LR	25.4 (1")	76	85	27	38	130	34	45	N850LCK, N1000LCK

■ MCK

Unit : mm

Model	Nut outside dia.	S	φD1	L1	T1	T2	Applicable torque wrench
50MCK	10 ~ 26	49	12	57	10	5.5	N50GCK, N50BCK, N50LCK, N50HYK
100MCK	10 ~ 30	59	15	65	12	6	N100GCK, N140GCK, N100BCK, N100LCK, N100HYK
200MCK	17 ~ 38	67	18	80	13	6.5	N200GCK, N200LCK, N200HYK

HEADS

OPTIONAL REPLACEABLE HEADS

SCK (Open End head)

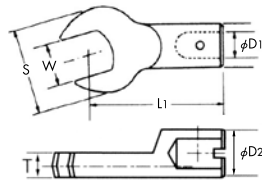

QCK (Ratchet head)

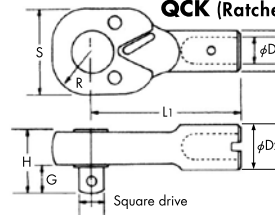

■ SCK open end heads

Unit : mm

Old Model	New Model	Size (W)					S	T	L1	φD1	φD2	Applicable torque wrench
		7	8	9	10	11						
230SCK	25SCK	7	8	9	10	11	29	7	45	10	16	60-250LCK, N6-N25LCK, 60-250SPCK, N6-N25SPCK, 250GCK, N25GCK, DTC-20REV, DTC-50REV, DTC-100REV, DTC-CN200REV, DTC-CN500REV, DTC-N10REV, DTC-PI-40REV, DTC-PI80REV
		12	13	14	15	16	32					
		17	19	21	22		39					
		24	27				45					
450SCK	50SCK	8	9	10	11		32	8	55	12	20	500LCK, N50LCK, 500SPCK, N50SPCK, 500GCK, N50GCK, DTC-500REV, DTC-N50REV, DTC-PI400REV, DLT-N50UC
		12	13	14	15	16	36					
		17	19	21	22		44					
		24	27				50					
900SCK	100SCK	12	13	14	15		40	10	65	15	24	1000LCK, N100LCK, 1000SPCK, N100SPCK, 1000, 1400GCK, 1000BCK, 1400BCK, N100BCK, N140BCK, N100, N140GCK, DTC-1000REV, DTC-N100REV, DTC-PI800REV, DLT-N100-UC
		16	17	19	21	22	48					
		24	27	30	32		57					
		17	19	21	22		56					
1800SCK	200SCK	24	27	30			64	14	80	18	28	2000LCK, N200LCK, 2000SPCK, N200SPCK, 2000GCK, N200GCK, DTC-2000REV, DTC-N200REV, DTC-PF100REV, DLT-N200-UC
		32	36	41			75					
		19					59	16				
		21	22				61					
2800SCK	280SCK	24					63	16.5	100	22	30	2800LCK, N280LCK, 2800SPCK, N280SPCK, DTC-3000REV, DTC-N300REV, DTC-PF200REV
		27					67					
		30					69					
		32					71					
		36					75					
		41					80					
		46					85					
4400SCK	440SCK	19	22	24			70	20	125	30	41	5600, 7000LCK, N560, N700LCK, DTC-5000REV, DTC-N500REV, DTC-PF400REV
		27	30	32			78					
		36	41				84					
		46	50				94					
		55	60				100					
7000SCK	700SCK	22	24				80	25	130	34	45	8500, 10000LCK, N850, N1000LCK, DTC-10000REV, DTC-N1000REV
		27					83					
		30					86					
		32					88					
		36					91					
		41					95					
		46					98					
		50					102					
		55					105					
		60					110					
10000SCK	1000SCK	27					84	30	160	38	50	15000LCK, N1500LCK
		30	32				90					
		36					95					
		41					100					
		46					106					
		50					110					
		55					115					
14000SCK	1500SCK	41					110	32	160	38	50	15000LCK, N1500LCK
		46					115					
		50					120					
		55					122					
		60					127					
		65					130					

■ QCK ratchet heads

Unit : mm

Old Model	New Model	Sq. drive	S	H	G	R	L1	φD1	φD2	Applicable torque wrench
120QCK	12QCK	6.35 (1/4")	24	19	7.5	12	45	10	16	60-250LCK, N6-N25LCK, 60-250SPCK, N6-N25SPCK, 250GCK, N25GCK, DTC-20REV, DTC-50REV, DTC-100REV, DTC-CN200REV, DTC-CN500REV, DTC-N10REV, DTC-PI-40REV, DTC-PI80REV
230QCK	25QCK	9.53 (3/8")	31	25	11	15.5	55	12	18	500LCK, N50LCK, 500SPCK, N50SPCK, 500GCK, N50GCK, DTC-500REV, DTC-N50REV, DTC-PI400REV, DLT-N50UC
450QCK	50QCK	12.7 (1/2")	39	31	14	19.7	65	15	24	1000LCK, N100LCK, 1000SPCK, N100SPCK, 1000, 1400GCK, 1000BCK, 1400BCK, N100BCK, N140BCK, N100, N140GCK, DTC-1000REV, DTC-N100REV, DTC-PI800REV, DLT-N100-UC
900QCK	100QCK	19.05 (3/4")	46	33	20	23	80	18	26	2000LCK, N200LCK, 2000SPCK, N200SPCK, 2000GCK, N200GCK, DTC-2000REV, DTC-N200REV, DTC-PF100REV, DLT-N200-UC
1800QCK	200QCK	25.4 (1")	54	42.5	27	34	125	30	41	2800LCK, N280LCK, 2800SPCK, N280SPCK, DTC-3000REV, DTC-N300REV, DTC-PF200REV
2800QCK-A	280QCK-A	25.4 (1")	68	50	34	125	30	41	45	4400LCK, N440LCK, 4400SPCK, N440SPCK
4400QCK	440QCK	25.4 (1")	76	58	27	38	130	34	45	5600, 7000LCK, N560, N700LCK, DTC-5000REV, DTC-N500REV, DTC-PF400REV
7000QCK	700QCK	25.4 (1")	87	61	28.5	43.5	160	38	52	8500, 10000LCK, N850, N1000LCK, DTC-10000REV, DTC-N1000REV, DTC-PF800REV
10000QCK	1000QCK	25.4 (1")								
21000QCK	2100QCK	25.4 (1")								

* is the new model that is applied from 1st January, 2016.

HEADS

OPTIONAL REPLACEABLE HEADS

RCK (Ring head)

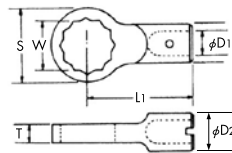

HCK (Hex drive head)

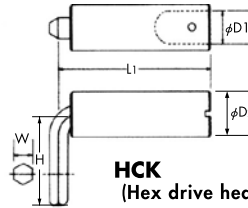

RCK ring heads

Unit : mm

Old Model	New Model	Size (W)				S	T	L ₁	φ D ₁	φ D ₂	Applicable torque wrench
		7	8	9	10						
230RCK	25RCK	7				18	8	45	10	16	60-250LCK, N6-N25LCK, 60-250SPCK, N6-N25SPCK, 250GCK, N25GCK, DTC-20REV, DTC-50REV, DTC-100REV, DTC-CN200REV, DTC-CN500REV, DTC-N10REV, DTC-PI-40REV, DTC-PI80REV
		11				21					
		12	13	14		31					
		17	19	22		32					
450RCK	50RCK	8	10			19	10	55	12	20	500LCK, N50LCK, 500SPCK, N50SPCK, 500GCK, N50GCK, DTC-500REV, DTC-N50REV, DTC-PI400REV, DLT-N50UC
		11	12	13	14	22					
		17	19	22		32					
900RCK	100RCK	12	13	14		25	13	65	15	23	1000LCK, N100LCK, 1000SPCK, N100SPCK, 1000, 1400GCK, N100, 1000BCK, 1400BCK, N100BCK, N140BCK, N140GCK, DTC-1000REV, DTC-N100REV, DTC-PI800REV, DLT-N100-UC
		17	19	21	22	34					
		24	27	30		42					
		17	19	22		35					
1800RCK	200RCK	24	27	30		45	15	80	18	27	2000LCK, N200LCK, 2000SPCK, N200SPCK, 2000GCK, N200GCK, DTC-2000REV, DTC-N200REV, DTC-PF100REV, DLT-N200-UC
		32	36	41		58					
		19	22	24		40					
		27	30	32		47					
2800RCK	280RCK	36	41			63	17				2800LCK, N280LCK, 2800SPCK, N280SPCK, DTC-3000REV, DTC-N300REV, DTC-PF200REV
		46				63					
		19	22	24		44					
		27	30	32		50					
4400RCK	440RCK	36	41			58	20	100	22	30	4400LCK, N440LCK, 4400SPCK, N440SPCK
		46	50			66					
		55	60			80					
		22	24			52					
7000RCK	700RCK	27	30	32		57	20	125	30	41	5600, 7000LCK, N560, N700LCK, DTC-5000REV, DTC-N500REV, DTC-PF400REV
		36				62					
		41				70					
		46	50			80					
		55				80					
10000RCK	1000RCK	27	30	32		60	25	130	34	45	8500, 10000LCK, N850, N1000LCK, DTC-10000REV, DTC-N1000REV
		36				65					
		41				72					
		46				80					
		50				80					
		55				80					
14000RCK	1500RCK	41				75	27	160	38	50	15000LCK, N1500LCK
		46				80					
		50				80					
		55				90					
		60				90					
		65				35					

HCK hex drive heads

Unit : mm

Old Model	New Model	Size (W)	L ₁	φ D ₁	φ D ₂	Size (H)	Applicable torque wrench
230HCK	25HCK	2.5	45	10	16	19	60-250LCK, N6-N25LCK, 60-250SPCK, N6-N25SPCK, 250GCK, N25GCK, DTC-20REV, DTC-50REV, DTC-100REV, DTC-CN200REV, DTC-CN500REV, DTC-N10REV, DTC-PI-40REV, DTC-PI80REV
		3				22	
		4				25	
		5				30	
		6				35	
		8				40	
450HCK	50HCK	4	55	12	20	27	500LCK, N50LCK, 500SPCK, N50SPCK, 500GCK, N50GCK, DTC-500REV, DTC-N50REV, DTC-PI400REV, DLT-N50UC
		5				30	
		6				35	
		8				40	
		10				45	
		6				35	
900HCK	100HCK	8	65	15	23	40	1000LCK, N100LCK, 1000SPCK, N100SPCK, 1000, 1400GCK, N100, N140GCK, 1000BCK, 1400BCK, N100BCK, N140BCK, DTC-1000REV, DTC-N100REV, DTC-PI800REV, DLT-N100-UC
		10				45	
		12				51	
		14				63	
		8				40	
		10				45	
1800HCK	200HCK	12	80	18	28	51	2000LCK, N200LCK, 2000SPCK, N200SPCK, 2000GCK, N200GCK, DTC-2000REV, DTC-N200REV, DTC-PF100REV, DLT-N200-UC
		14				51	
		17				63	
		17				72	
		12				51	
		14				63	
2800HCK	280HCK	17	100	22	30	71	2800LCK, N280LCK, 2800SPCK, N280SPCK, DTC-3000REV, DTC-N300REV, DTC-PF200REV
		19				80	

* is the new model that is applied from 1st January, 2016.

SPK PRE-SET TORQUE WRENCHES

Audible and tangible "CLICK" when the set torque is reached, assuring a securely tightened joint. This series is well-suited for production line use.

FEATURES

- A single function wrench, used for a single setting combination of fastener size and torque setting.
- Most suited for tightening multiple same-size fasteners at the same torque in a production line.
- Setting confirmation unnecessary.
- Can be used effectively in confined spaces.
- Tightening to set torque only in the direction of the arrow indicator, but can be used for general tightening in the other direction as well.
- Accuracy : $\pm 3\%$ of pre-set value

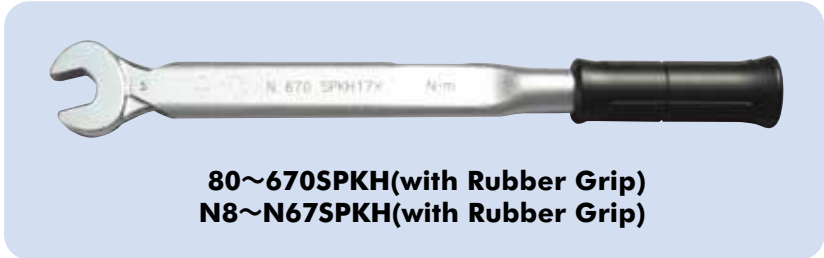
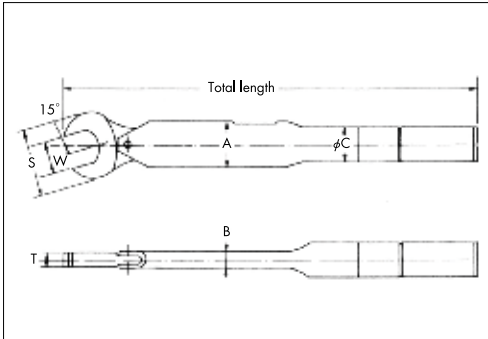

EXAMPLE OF ORDER

Model Size(W) Pre-set Value
| | |
N19SPK 10 × 14N·m

Model (kgf·cm)	Range kgf·cm	Old Model (N·m)	New Model (N·m)	Range N·m	Spanner sizes (W) mm						Total length mm	Dimensions (mm)					Weight kg
												Head		Body			
					S	T	A	B	C								
30SPK	5~30	N30SPK	N35SPK	0.5~3	5.5	6	7	8	9	10	152	24	5	19.5	7.5	15	0.1
80SPK	15~80	N80SPK	N85SPK	1.5~8	5.5	6	7	8	9	10	175	24	5	19.5	7.5	15	0.11
190SPK	35~190	N190SPK	N195SPK	3.5~19	10	11	12	13	14	203	27	7	19.5	7.5	15	0.15	
380SPK	80~380	N380SPK	N385SPK	8~38	12	13	14	15	16	213	35	8	26.6	8.2	20	0.29	
670SPK	130~670	N670SPK	N675SPK	13~67	17	19	21	23	24	248	35	11	25.8	9.7	20	0.45	
1200SPK	240~1,200	N1200SPK	N1205SPK	24~120	21	22	23	24	26	325	50	12	32.8	11.3	25	0.46	
1600SPK	300~1,600	N1600SPK	N1605SPK	30~160	27	30	32	36	41	330	56	14	32.8	11.3	25	0.47	
2200SPK	450~2,200	N2200SPK	N2205SPK	45~220	36	41	46	52	60	342	65	14	32.8	11.3	25	0.49	
3100SPK	650~3,100	N3100SPK	N3105SPK	65~310	41	46	52	60	70	390	52	15	35.6	12.5	27.2	0.75	
4200SPK	900~4,200	N4200SPK	N4205SPK	90~420	24	26	27	30	32	397	57	16	38.0	16	30	0.79	
					29	30	32	36	41	403	62	18	43.3	17.8	34	0.81	
					36	41	46	52	60	404	64	18	43.3	17.8	34	0.84	
					41	46	52	60	70	435	52	19	43.3	17.8	34	0.94	
					46	52	60	70	80	442	57	19	43.3	17.8	34	0.97	
					52	60	70	80	90	449	64	19	43.3	17.8	34	0.99	
					60	70	80	90	100	457	73	19	43.3	17.8	34	1.1	
					70	80	90	100	110	585	72	15	35.6	12.5	27.2	1.1	
					80	90	100	110	120	597	90	15	35.6	12.5	27.2	1.2	
					90	100	110	120	130	650	65	16	38.0	16	30	1.3	
					100	110	120	130	140	654	70	16	38.0	16	30	1.32	
					110	120	130	140	150	662	82	16	38.0	16	30	1.4	
					120	130	140	150	160	833	74	19	43.3	17.8	34	1.45	
					130	140	150	160	170	838	76	19	43.3	17.8	34	1.46	
					140	150	160	170	180	843	78	18	43.3	17.8	34	1.47	
					150	160	170	180	190	847	88	18	43.3	17.8	34	1.5	
					160	170	180	190	200	860	94	18	43.3	17.8	34	1.52	

* is the new model that is applied from 1st January, 2016.

RSPK PRE-SET, RING TORQUE WRENCHES

Can be used for accurate torque application even on joints inaccessible with other wrenches.

FEATURES

- The ring head of RSPK wrenches is offset at a 45° angle making certain joints particularly accessible.
- A single function wrench, used for a single setting combination of fastener size and torque setting.
- Most suited for tightening multiple same-size fasteners at the same torque on a production line.
- Setting confirmation unnecessary.
- Accuracy : ±3% of pre-set value

EXAMPLE OF ORDER

Model Size(W) Pre-set Value
 | | |
 N21RSPK 10 × 14N·m

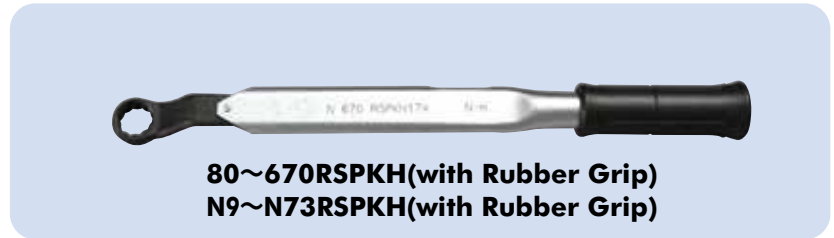

Model	★1 Ring head sizes (W)			★2 Dimensions Head			Model	★1 Ring head sizes (W)			★2 Dimensions Head			Model	★1 Ring head sizes (W)			★2 Dimensions Head				
	mm	S	T	mm	S	T		mm	S	T	mm	S	T		mm	S	T					
30RSPK N3.5RSPK	5.5		4	80RSPK N9RSPK	5.5		4	190RSPK N21RSPK	10	16	7	30~190RSPK N3.5~N21RSPK	10	16	7	380~4200RSPK N42~N430RSPK	11	18		11	18	8
	6	10	5		6	10	5		11	18			11	18			12	19	8			
	7				7				12	19	8		12	19	8		13	20	8.5			
	8	13	6		8	13	6		13	20	8.5		14	22	9		14	22	9			
	9	14			9	14			14	22	9		17	26	10		17	26	10			
10	16	7	10	16	7	17	26	10	19	29	10.5	19	29	10.5	22	33	12					
			11	18		19	29	10.5														
			12	19	8	22	33	12														

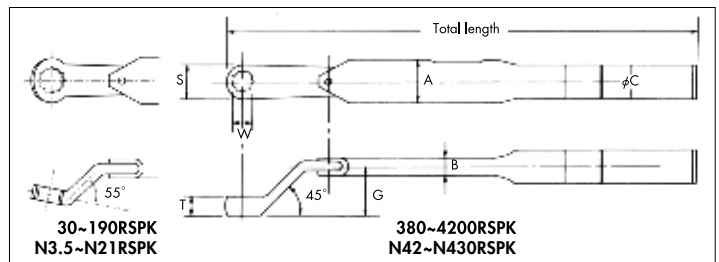

Model (kgf·cm)	Range (kgf·cm)	Old Model (N·m)	New Model (N·m)	Range (N·m)	Ring head sizes (W)				Total length (mm)	Dimensions (mm)						Weight (kg)
					mm					S	T	Body				
					mm							G	A	B	C	
30RSPK	5~35	N30RSPK	N3.5RSPK	0.5~3.5	5.5	6			175	★1	10	19.5	7.5	15	0.12	
					7	8	9	10								
80RSPK	20~90	N80RSPK	N9RSPK	2~9	5.5	6	7		197	★2	10	19.5	7.5	15	0.13	
					8	9	10									
					11	12										
190RSPK	40~210	N190RSPK	N21RSPK	4~21	10				222	★3	10	19.5	7.5	15	0.21	
					11	12	13	14								
					17	19	22									
					22	28										
					28	34										
380RSPK	90~420	N380RSPK	N42RSPK	9~42	11	12	13	14	268	★3	10	25	26.6	8.2	20	0.31
					17	19	22									
					14	17										
					19	22	24									
670RSPK	140~730	N670RSPK	N73RSPK	14~73	27	30	32		353	★3	10	27	25.8	9.7	20	0.46
					27	30	32									
					30	32										
					34	36										
					36	38										
1200RSPK	250~1,270	N1200RSPK	N127RSPK	25~127	14				413	★3	12	29	32.8	11.3	25	0.5
					17											
					19	22										
					24											
					27	30	32									
					36											
					42											
1600RSPK	320~1,700	N1600RSPK	N170RSPK	32~170	19	22	24		470	★3	15	31	32.8	11.3	25	1.0
					27	30	32									
					19											
					22	24	27									
					30	32										
2200RSPK	480~2,300	N2200RSPK	N230RSPK	48~230	19				605	★3	16.5	33	35.6	12.5	27.2	1.2
					22	24	27									
					30	32										
					36											
					41											
					41											
3100RSPK	680~3,200	N3100RSPK	N320RSPK	68~320	22				682	★3	18	35	38	16	30	1.35
					24	27	30									
					32	36										
					41											
					41											
4200RSPK	950~4,300	N4200RSPK	N430RSPK	95~430	27	30	32		880	★3	18	37	43.3	17.8	34	1.55
					36											
					41											
					41											
					46											
					46											

* is the new model that is applied from 1st January, 2016.

QLK-LR LARGE HUB NUT TORQUE WRENCHES

Ideal for tightening hub nuts on large trucks and buses

FEATURES

- Dual square drives for both clockwise and counterclockwise tightening.
- By replacing the sockets, various sizes of fasteners can be tightened within the tool's capacity range.
- Tightening to a torque setting, can only be done in the direction of the arrow.
- Accuracy : $\pm 3\%$ of indicated value over the full range

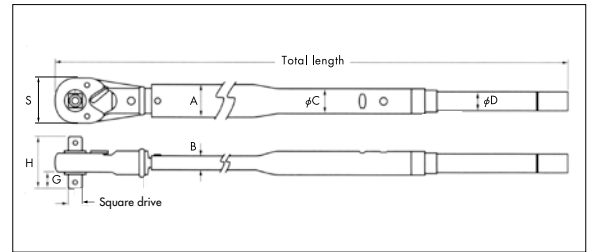

Model (kgf·m)	Range	Increment	Old Model (N·m)	New Model (N·m)	Range	Increment	Square drive	Total length	Dimensions (mm)								Weight	Standard Accessory						
									kgf·m		N·m		mm		Head				Body					
															S	G			H	A	B	φC	φD	kg
7000QLK-LR	10~70	0.5	N7000QLK-LR	N700QLK-LR	100~700	5	19.05 (3/4")	1,314	68	20	70	49	20	35.4	27.2	7.0	Torque adjusting box wrench							
8500QLK-LR	10~85		N8500QLK-LR	N850QLK-LR	100~850		25.4 (1")	1,388								8.5								
10000QLK-LR	10~100		N10000QLK-LR	N1000QLK-LR	100~1000			1,538	76	27	85	54	23	42.7	31.8	8.8								

HYK ADJUSTABLE WRENCH HEADS, ADJUSTABLE TORQUE WRENCHES

Built-in "no play" worm screw

FEATURES

- Since the head can be taken off and reversed, the wrench can be used in confined spaces (in as small as a 30 degree turn) previously inaccessible to even other adjustable wrenches. (Tightening to a torque setting can only be done in the direction of the arrow.)
- There is hardly any play in the worm screw adjuster in the wrench head, which will improve your working efficiency. Without excess play, the torque wrench will not damage the corners of fasteners like ordinary wrenches will.
- Accuracy : $\pm 4\%$ of indicated value over the full range

USING AN HYK

Setting the opening

- (1) Slide the jaws onto the fastener until it contacts the spring pin. (a)
- (2) Tighten the adjusting worm screw so the jaws grip the fastener. (b)
- (3) Loosen the adjusting worm screw just enough to allow removing the wrench from the fastener. (c)

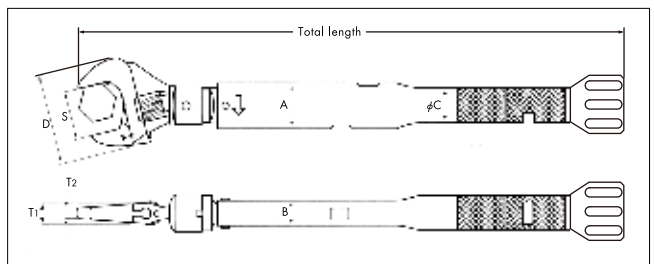
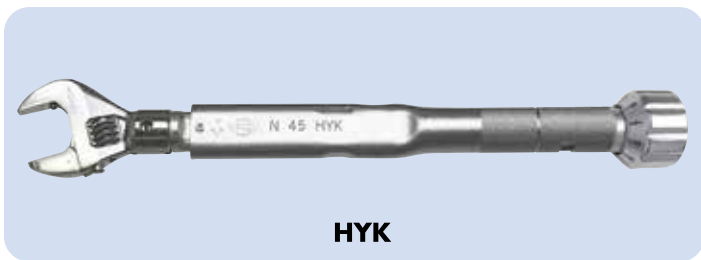
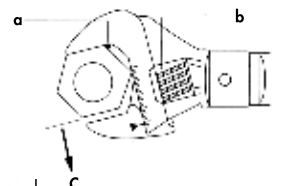

Model (kgf·m)	Range	Increment	Model (N·m)	Range	Increment	Total length	Opening Size(mm)	Dimensions (mm)								Weight						
								kgf·cm		N·m		mm		Head				Body				
														S	D		T1	T2	A	B	φC	kg
500HYK	100~500	5	N50HYK	10~50	0.5	288	10~26	49	10	5.5	25	11.4	20	0.48								
1000HYK	200~1000	10	N100HYK	20~100	1	393	10~30	59	12	6	27.5	12.4	21.7	0.76								
2000HYK	400~2000	20	N200HYK	40~200	2	531	17~38	67	12.5	6.5	34	15.4	27.2	1.47								

MLQK MARKING TORQUE WRENCHES

No tightening negligence with marking check.

FEATURES

- To click torque wrench and the bolt is painted.
No marking without click.
- 6000 times can be marked with 14 to 24mm socket.
- 1500 times can be marked with 8 to 13mm socket.
- Easy maintenance.
- Accuracy : $\pm 3\%$
- Please select the size of socket when you order MQLK.
Socket is modified for MQLK

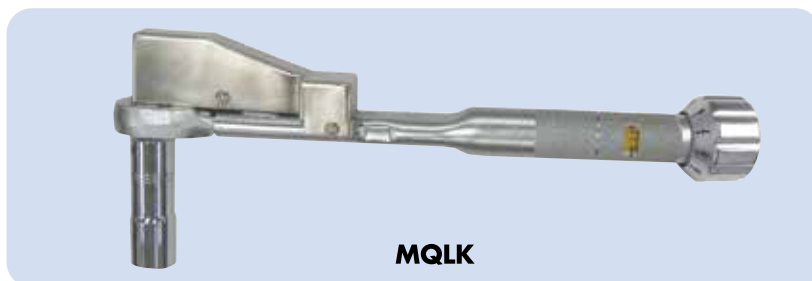

MLQK

* Ink is not included

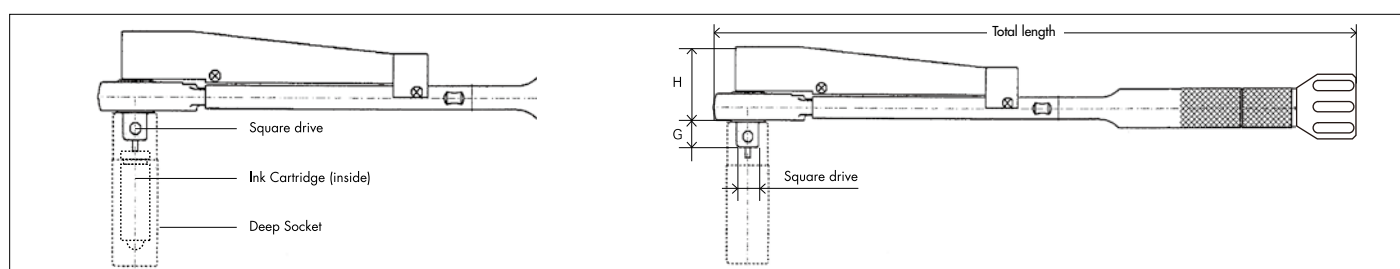

Model (kgf·cm)	Range kgf·cm	Increment	Old Model (N·m)	New Model (N·m)	Range N·m	Increment	Square drive mm	Total length mm	Dimensions (mm)			Weight kg	Optional socket mm
									Head				
									H	G			
250MQLK	70~250	2	N250MQLK	N25MQLK	7~25	0.2	9.53	232	54	11	0.38	8~24	
500MQLK	100~500	5	N500MQLK	N50MQLK	10~50	0.5	(3/8")	257	54	11	0.57	8~24	
1000MQLK	200~1,000	10	N1000MQLK	N100MQLK	20~100	1	12.7	359	57	14	0.91	13~24	
1400MQLK	400~1,400	10	N1400MQLK	N140MQLK	40~140	1	(1/2")	399	57	14	0.96	13~24	

MLQK-E HEXAGON MARKING TORQUE WRENCHES

No tightening negligence with marking check.

FEATURES

- A mark is automatically painted when the specified torque is reached; an electric signal is triggered to pop up the paint marker at the tip of the wrench to mark.
- Marking position is finely adjustable front to back and side to side. Marks can also be printed on the side of a socket bolt, or the head or periphery of a buried bolt.
- The marker: $\phi 11$ (Marker pen is not included.)

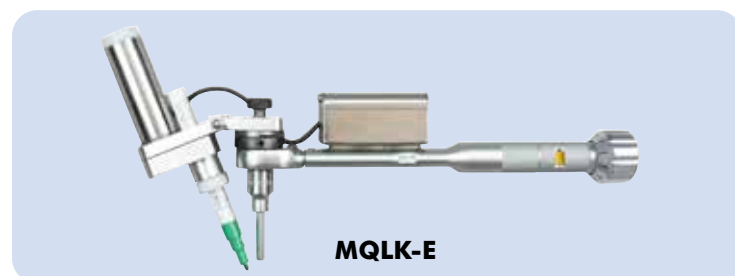

MLQK-E

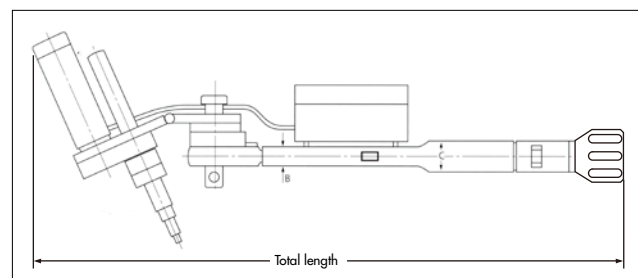

BATTERY CHARGER SPECIFICATIONS

- Input : 100-240VAC, 50/60Hz
- Cell : 2S and 3S
- Output current : 3 x 850mA



Model (kgf·cm)	Range kgf·cm	Increment	Old Model (N·m)	New Model (N·m)	Range N·m	Increment	Square drive mm	Total length mm	Dimensions (mm)			Weight kg
									B	C		
60MQLK-E	20~60	1	N60MQLK-E	N6MQLK-E	2~6	0.1						0.7
120MQLK-E	40~120	2	N120MQLK-E	N12MQLK-E	4~12	0.2	9.53	327	10	15		0.8
250MQLK-E	70~250	2	N250MQLK-E	N25MQLK-E	7~25	0.2	(3/8")					
500MQLK-E	100~500	5	N500MQLK-E	N50MQLK-E	10~50	0.5		352		20		1
1000MQLK-E	200~1000	10	N1000MQLK-E	N100MQLK-E	20~100	1	12.7	459	12	22		1.3
1400MQLK-E	400~1400	10	N1400MQLK-E	N140MQLK-E	40~140	1	(1/2")	499				1.4

* is the new model that is applied from 1st January, 2016.

TCSK-99MA

MULTI-FUNCTION TORQUE TASK MANAGER / ANALYZER

The multi-controller, the "Careless Mistake Detector" has a 100-240V multi-input type power system.

SWPMSeries

TORQUE TOOLS FOR TCSK

SWPM tools connect with TCSK-99MA and prevent missing tightening joints.

TCSK-99MA



N-QLK-SWPM

This is an extremely useful multi-function controller that can serve many purposes, such as detecting loose joints, eliminating faulty fastener tightening, and task time management through connection with a KANON torque wrench, or torque driver.

FEATURES

- TCSK-99MA connects to KANON SWPM series torque tools.
- The red LED indicators are large and easy-to-read, allowing the operator to check the settings and progress of fastener tightening work at a glance. With visible and audible signals, the TCSK-99MA prevents you from leaving joints loose during fastener tightening work.
- Compared with conventional products, TCSK-99MA offers many different functions at a lower price.
- TCSK-99MA can help manage work processes via external output signals.

* This item does not have the CE mark.

Model	TCSK-99MA
Count	1 to 99
Timer setting	Digital input (set time for each function)
Judgement	OK (sounds and LED lights up in green) NG (sounds and LED lights up in red)
External input	Start, stop, reset, direction of rotation, work, lock
External output	Count OK, work NG/OK, overtime NG, in-time NG
Power supply	Input (primary side), switching power type multi-input of 100 to 240 VAC Output(secondary side) 24VDC, 2A 50W
Power consumption	10W
Outside dimensions	209mm (W)×77mm(H)×180mm(D)
Weight	approximately 1.7kg

FEATURES

- When the tool clicks, indicating the joint is tightened to the specified torque, a signal is sent to the TCSK-99MA.

SWPM TYPES ● Type and torque range

Model	Available Models
SPK-SWPM	190SPK~3100SPK N19SPK~N310SPK
RSPK-SWPM	190RSPK~3100RSPK N21RSPK~N320RSPK
QSPK-SWPM	PI60QSPK~PI2800QSPK 60QSPK~2800QSPK N6QSPK~N280QSPK
SPCK-SWPM	60SPCK~2800SPCK N6SPCK~N280SPCK

- Accuracy : $\pm 3\%$ of pre-set value

QLK-SWPM	PI60QLK~PI2000QLK 60QLK~2000QLK N6QLK~N200QLK
LCK-SWPM	60LCK~2000LCK N6LCK~N200LCK

- Accuracy : $\pm 3\%$ of indicated value over the full range

LTDK-SWP	OI200LTDK / PI30LTDK~PI50LTDK 12LTDK~100LTDK CN120LTDK~N10LTDK
----------	--

- Accuracy : $\pm 3\%$ of indicated value over the full range, clockwise

ZLK

KANON insulated adjustable type torque wrench

Special 2-layer insulation coating preventing shock hazard

FEATURES

- Torque value preset is available within the capacity according to your need.
- Special 2-layer insulation coating is a risk protection for users against shock hazard.
- Damage to coating is easy to recognize from the different color for the top and the bottom layer of special 2-layer insulation coating.
- Withstand voltage is 240V at maximum.
- Best for maintenance and inspection for electric vehicles
- Exclusive design for cw tightening
- The accuracy is guaranteed within a tolerance of 3%.

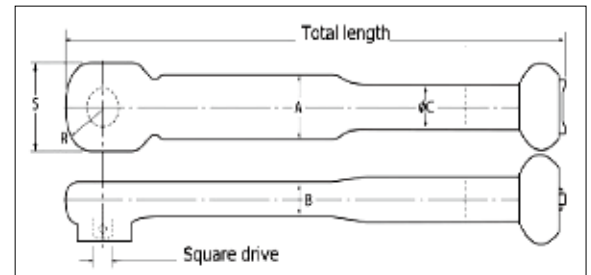

Model (N·m)	Range	Increment	Square Drive	Total length	Dimensions (mm)					Weight
					Head		Body			
					S	R	A	B	φC	
N50ZLK	10~50	0.5	9.53 (3/8")	287	38	19	31	17.4	21	0.52
N100ZLK	20~100	1	12.7 (1/2")	392	45	22.5	33.5	19.4	23	0.89

FK

INDICATOR PLATE TORQUE WRENCHES

Quite suitable for general tightening and for checking torque on previously tightened joints. A popular series with fan-shaped indicator plate scales.

FEATURES

- The simple structure and small friction area give this series of tools a long life.
- Strong and easy to handle.
- Accuracy : ±3% of indicated value over the full range

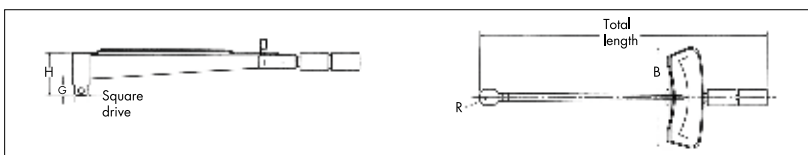
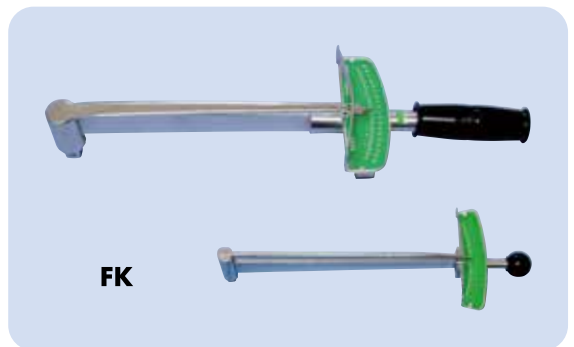

Old Model (N·m)	New Model (N·m)	Range (CW/CCW)	Increment	Sq.drive	Total length	Dimensions (mm)				Weight
						Head		Body		
						H	G	R	B	
N7FK	CN70FK	10~70 //	2 //	6.35 (1/4")	132	7.5	5	75	0.05	
N15FK	CN150FK	50~150 //	5 //		140				0.08	
N30FK	N3FK	1~3 N·m	0.1 N·m		170				0.1	
N60FK	N6FK	1~6 //	0.2 //		190				0.22	
N120FK	N12FK	2~12 //	0.5 //		237				0.25	
N230FK	N23FK	3~23 //	0.5 //	9.53 (3/8")	290	11	9	106	0.3	
N450FK	N45FK	5~45 //	1 //	320	0.34					
N900FK	N90FK	10~90 //	2 //	12.7 (1/2")	388	14	12.5	114	1.1	
N1300FK	N130FK	20~130 //	2 //		441				1.2	
N1800FK	N180FK	30~180 //	5 //		487				1.3	
N2800FK	N280FK	50~280 //	5 //		587				2.6	
N4200FK	N420FK	70~420 //	10 //	19.05 (3/4")	853	20	28	186	3.5	

* is the new model that is applied from 1st January, 2016.

TOK-G DIAL INDICATOR TORQUE WRENCHES

Easy to read dial indicator. Well suited for inspection and general maintenance service.



TOK-G (with peak indicator)



FEATURES

- Oval design with comfort rubber grip reduces strain.
- Easily readable for inspections.
- Useful for general tightening work.
- Accuracy : $\pm 3\%$ of indicated value over the full range

USING A TOK WRENCH

- (1) Turn the dial cap and set the indicator to 0.
 - (2) Mount a socket on the square drive.
 - (3) Tighten until the indicator points to the desired torque.
- * When using a peak indicator wrench, set it to 0 before tightening.

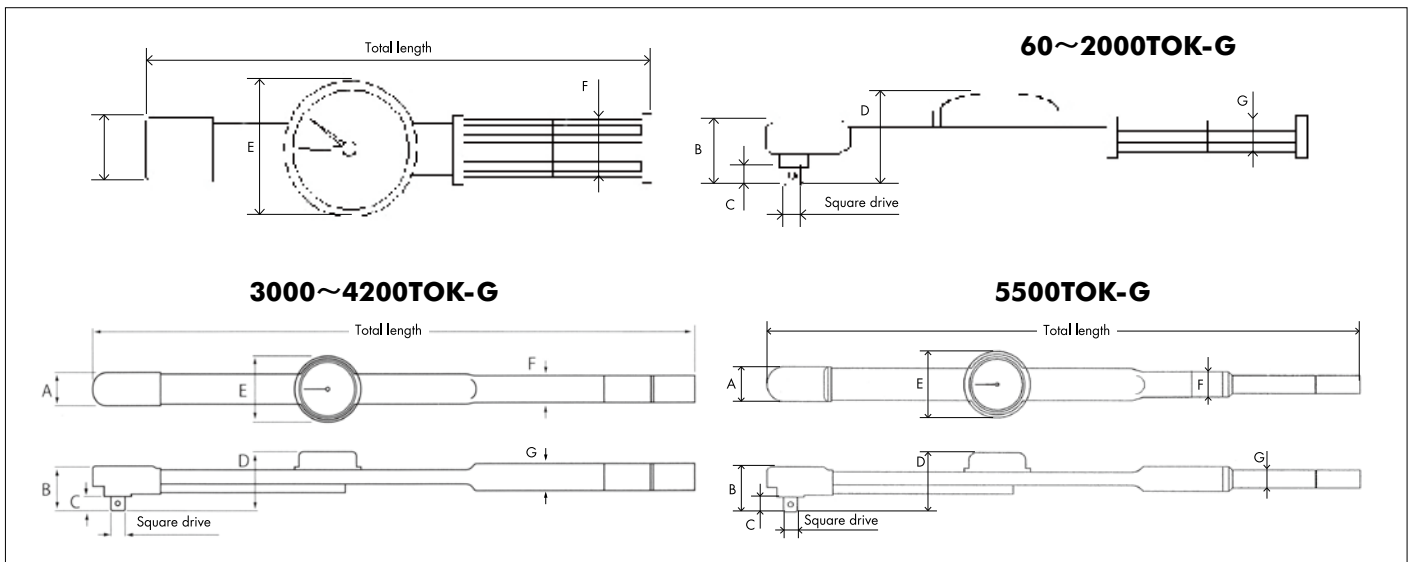

Model (kgf·cm/kgf·m)	Range (CW/CCW)	Increment	Model (N·m)	Range (CW/CCW)	Increment	Square drive	Total length	Dimensions (mm)							Weight kg
								Head			Body				
	kgf·cm/kgf·m			N·m		mm	mm	A	B	C	D	E	F	G	
60TOK-G	6~60	1 kgf·cm	N 6TOK-G	0.6~6	0.1	6.35 (1/4")	260	35	38.5	7.5	58	90	37	21.5	0.5
120TOK-G	10~120	2	N 12TOK-G	1~12	0.2										
300TOK-G	50~300	5	N 30TOK-G	5~30	0.5										
500TOK-G	50~500	5	N 50TOK-G	5~50	0.5	9.53 (3/8")	323	35	43	11	60	90	37	21.5	0.61
700TOK-G	100~700	10	N 70TOK-G	10~70	1										
1400TOK-G	200~1,400	20	N 140TOK-G	20~140	2	12.7 (1/2")	463	39	49	14	65	90	41	22.5	0.87
2000TOK-G	200~2,000	20	N 200TOK-G	20~200	2										
3000TOK-G	3~30	0.5 kgf·m	N 300TOK-G	30~300	5		682	41	55						1.6
4200TOK-G	4~42	1	N 420TOK-G	40~420	10	19.05 (3/4")	955	48		20	77	90			2.5
5500TOK-G	5~55	1	N 550TOK-G	50~550	10		1,110	50	60		80				3.8

DLT-N KANON DIGITAL TORQUE WRENCH

Digital control for ease of use and handling. Precise control of torque at a low cost.



DLT-N100

Optional Replaceable Heads (Refer to the page 10)



SCK
(Open End head)



RCK
(Ring head)



HCK
(Hex drive head)

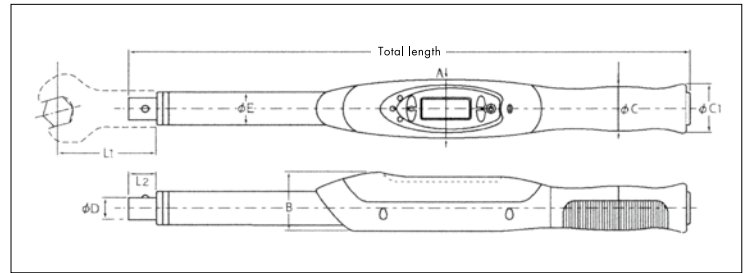

FEATURES

- The digital torque wrench DLT-N series measures and digitally displays tightening torque and return torque.
- Preset function: Set the tightening torque before operation, and the LED and a buzzer tell you when the preset torque is reached during operation.
- Data memory function: Connect the torque wrench after use to your PC, and the measurement data is stored in the PC for editing in the Excel format (Windows Excel only).
- Powered by 2 rechargeable nickel-metal hydride (Ni-MH) batteries, which are recharged via the USB port of the torque wrench while they are in the wrench.
- Auto power-off: Saves power to enable use of the unit for a longer time.
- Calendar function: Date and time of tightening operations are stored in the memory.
- Smart and slim design based on a new concept.
- The head is easily replaceable to suit different purposes of use.
- ±1% + 1 digit guaranteed accuracy (±3% + 1 digit for DLT-N50-UC).

Names and Functions of Components

⑧ Side



- ① Power key
Power ON/OFF; clears measured value in PA mode.
- ② Data key
Saves and calls data.
- ③ Mode key
Selects the measurement mode.
- ④ UP key
Sets tightening torque in the preset mode; searches a particular data in the data calling mode; sets calendar and clock.
- ⑤ DOWN key
Sets tightening torque in the preset mode; searches a particular data in the data calling mode; sets calendar and clock.
- ⑥ LED
Flashes to indicate that the preset torque is soon to be reach; an intermittent buzzer sounds. Lights up to indicate that the preset torque has been reached; a continuous buzzer sounds.
- ⑦ LCD display
Displays various data.
- ⑧ USB terminal
For battery charging and data outputting (Windows only).

Model	Range	Increment	Total length mm	Dimensions (mm)					Weight kg	Accessory			
				Head			Body						
				φD1	L1	L2	A	B	φC	φC1	φE		
DLT-N50-UC	10.00~50.00 N·m	0.01 N·m	411	12	55	15	47	47	37	40	27.2	0.8	50QCK
	7.38~36.87 ft·lb	0.01 ft·lb											
	88.5~442.5 in·lb	0.1 in·lb											
	102.0~509.8 kgf·cm	0.1 kgf·cm											
DLT-N100-UC	20.0~100.0 N·m	0.1 N·m	413	15	65	17	47	47	37	40	27.2	0.9	100QCK
	14.8~73.8 ft·lb	0.1 ft·lb											
	177~885 in·lb	1 in·lb											
	2.04~10.19 kgf·m	0.01 kgf·m											
DLT-N200-UC	40.0~200.0 N·m	0.1 N·m	457	18	80	22	47	47	37	40	27.2	1	200QCK
	29.6~147.5 ft·lb	0.1 ft·lb											
	354~1770 in·lb	1 in·lb											
	4.08~20.38 kgf·m	0.01 kgf·m											

[Common Specifications for DLT-N Series]

Accuracy	Data memory	Measurement mode	Alarm mode	Measurement method	Power source	Use time	Charge time	Auto power off	I/O terminal	Operating temperature range
±1% + 1 digit (±3% + 1 digit for DLT-N50)	999 data	RUN, PA, PC	LED and buzzer	CW/CCW auto switching	Ni-MH rechargeable batteries, size AA, 1.2V; 2 pieces	Approx. 20 hours with fully charged batteries (continuous use)	Max 5 hours. (approx.) for discharge and charge	After 60 seconds	USB terminal (for Windows) for data outputting and battery charging	+5 ~ +35°C

RUN : Current load value is shown continuously PA : The first peak value is detected and held. PC : Peak-to-peak and auto start

DTC-REV DATA OUTPUT DIGITAL TORQUE WRENCHES

Multi Function dataout put digital torque wrench with OLED display.



FEATURES

- Accuracy : $\pm 1\%$ of indicated value +1 increment, over full range
- Display : OLED
- Measuring mode : ①Peak hold ②Peak to Peak ③Tracking
- Measuring direction: CW / CCW changeover, provided with
: CW / CCW status display
- Power supply : Lithium-ion rechargeable battery 18650
: 100-240V battery charger
- Battery Life : Approx. 20 hours with fully charged
: battery. (continuous operation)
- Auto power-off : Approx. 30 minutes
- Tolerance setting : 1 to 10%. Automatic judgment for pre-set target torque
- Data input : 1000 data can be stored

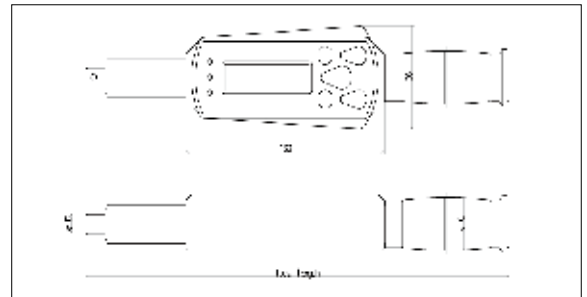

It can be measured tightening torque (CW) and loosening torque (CCW) with digital display.
When the pre-set target torque is achieved, it can be confirmed with change of sounds.
The preset values and tolerance can be set and the pass/fail judgment appears on LED.
Data include the date (year, month, date) and time (hour, min, second) in DTC-REV.
Since the OLED is high visibility, the display is easy to read even in the dark.

Model	Range(Unit)	Increment	Total length (mm)	ϕ D.	ϕ C	Weight (Kg)	Accessory
DTC-N10REV	1 ~ 10N·m	0.01N·m	314	10	35	0.8	12 QCK
DTC-N50REV	5 ~ 50N·m	0.01N·m	342	12	35	0.9	50 QCK
DTC-N100REV	10 ~ 100N·m	0.1N·m	386	15	35	1.1	100 QCK
DTC-N200REV	20 ~ 200N·m	0.1N·m	404	18	35	1.25	200 QCK
DTC-N300REV	30 ~ 300N·m	0.1N·m	535	22	35	1.8	280 QCK-A
DTC-N500REV	50 ~ 500N·m	0.1N·m	1063	30	34	4.2	700 QCK
DTC-N1000REV	100 ~ 1000N·m	1N·m	1417	34	34	7.6	1000 QCK
DTC-100REV	10 ~ 100kgf·cm	0.1kgf·cm	314	10	35	0.8	12 QCK
DTC-500REV	50 ~ 500kgf·cm	0.1kgf·cm	342	12	35	0.9	50 QCK
DTC-1000REV	100 ~ 1000kgf·cm	1kgf·cm	386	15	35	1.1	100 QCK
DTC-2000REV	200 ~ 2000kgf·cm	1kgf·cm	404	18	35	1.25	200 QCK
DTC-3000REV	3 ~ 30kgf·m	0.01kgf·m	535	22	35	1.8	280 QCK-A
DTC-5000REV	5 ~ 50kgf·m	0.01kgf·m	1063	30	34	4.2	700 QCK
DTC-10000REV	10 ~ 100kgf·m	0.1kgf·m	1417	34	34	7.6	1000 QCK
DTC-PI80REV	8 ~ 80lbf·in	0.01lbf·in	314	10	35	0.8	12 QCK
DTC-PI400REV	40 ~ 400lbf·in	0.1lbf·in	342	12	35	0.9	50 QCK
DTC-PI800REV	80 ~ 800lbf·in	0.1lbf·in	386	15	35	1.1	100 QCK
DTC-PF100REV	10 ~ 100lbf·ft	0.1lbf·ft	404	18	35	1.25	200 QCK
DTC-PF200REV	20 ~ 200lbf·ft	0.1lbf·ft	535	22	35	1.8	280 QCK-A
DTC-PF400REV	40 ~ 400lbf·ft	0.1lbf·ft	1063	30	34	4.2	700 QCK
DTC-PF800REV	80 ~ 800lbf·ft	1lbf·ft	1417	34	34	7.6	1000 QCK

Angle function is option: DTC-REV-A
Bluetooth function is option: DTC-REV-B (Certified in USA, Canada, Europe, Korea, Taiwan)

DTC-REV-A DATA OUTPUT DIGITAL TORQUE WRENCHES

Multi-function data output digital torque wrench with OLED display and with angle function.

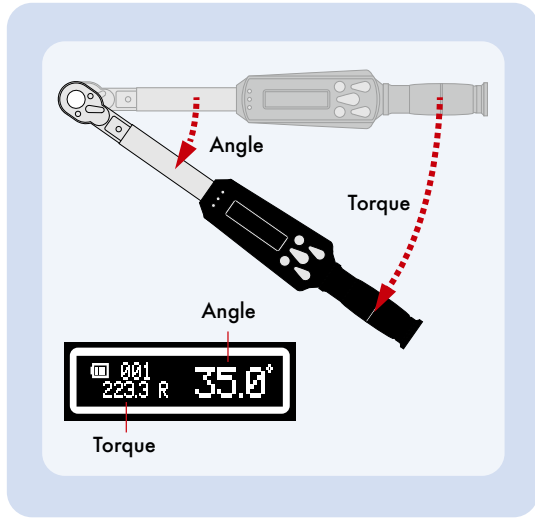

Model	Range(Unit)	Increment	Accessory
DTC-N10REV-A	1 ~ 10N·m	0.01N·m	12 QCK
DTC-N50REV-A	5 ~ 50N·m	0.01N·m	50 QCK
DTC-N100REV-A	10 ~ 100N·m	0.1N·m	100 QCK
DTC-N200REV-A	20 ~ 200N·m	0.1N·m	200 QCK
DTC-N300REV-A	30 ~ 300N·m	0.1N·m	280 QCK-A
DTC-N500REV-A	50 ~ 500N·m	0.1N·m	700 QCK
DTC-N1000REV-A	100 ~ 1000N·m	1N·m	1000 QCK
DTC-100REV-A	10 ~ 100kgf·cm	0.1kgf·cm	12 QCK
DTC-500REV-A	50 ~ 500kgf·cm	0.1kgf·cm	50 QCK
DTC-1000REV-A	100 ~ 1000kgf·cm	1kgf·cm	100 QCK
DTC-2000REV-A	200 ~ 2000kgf·cm	1kgf·cm	200 QCK
DTC-3000REV-A	3 ~ 30kgf·m	0.01kgf·m	280 QCK-A
DTC-5000REV-A	5 ~ 50kgf·m	0.01kgf·m	700 QCK
DTC-10000REV-A	10 ~ 100kgf·m	0.1kgf·m	1000 QCK
DTC-PI80REV-A	8 ~ 80lbf·in	0.01lbf·in	12 QCK
DTC-PI400REV-A	40 ~ 400lbf·in	0.1lbf·in	50 QCK
DTC-PI800REV-A	80 ~ 800lbf·in	0.1lbf·in	100 QCK
DTC-PF100REV-A	10 ~ 100lbf·ft	0.1lbf·ft	200 QCK
DTC-PF200REV-A	20 ~ 200lbf·ft	0.1lbf·ft	280 QCK-A
DTC-PF400REV-A	40 ~ 400lbf·ft	0.1lbf·ft	700 QCK
DTC-PF800REV-A	80 ~ 800lbf·ft	1lbf·ft	1000 QCK

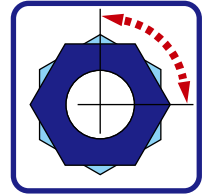

The tightening torque is displayed as an angle.
The torque and rotation angle are measured and displayed at the same time from the seated tighten screw as started point.

Dimensions of DTC-REV-A are same as DTC-REV.

DTC-REV-UW DATA OUTPUT DIGITAL TORQUE WRENCHES

Multi-function data output digital torque wrench connectable to the optional output device.



The measured data can be output to EXCEL on PC passed by U-WAVE without software.

OPTION

Mitutoyo
U-WAVE-TCB (264-625)



Mitutoyo
02AZD790E
cable



Model	Range(Unit)	Increment	Accessory
DTC-N10REV-UW	1 ~ 10N·m	0.01N·m	12 QCK
DTC-N50REV-UW	5 ~ 50N·m	0.01N·m	50 QCK
DTC-N100REV-UW	10 ~ 100N·m	0.1N·m	100 QCK
DTC-N200REV-UW	20 ~ 200N·m	0.1N·m	200 QCK
DTC-N300REV-UW	30 ~ 300N·m	0.1N·m	280 QCK-A
DTC-N500REV-UW	50 ~ 500N·m	0.1N·m	700 QCK
DTC-N1000REV-UW	100 ~ 1000N·m	1N·m	1000 QCK
DTC-100REV-UW	10 ~ 100kgf·cm	0.1kgf·cm	12 QCK
DTC-500REV-UW	50 ~ 500kgf·cm	0.1kgf·cm	50 QCK
DTC-1000REV-UW	100 ~ 1000kgf·cm	1kgf·cm	100 QCK
DTC-2000REV-UW	200 ~ 2000kgf·cm	1kgf·cm	200 QCK
DTC-3000REV-UW	3 ~ 30kgf·m	0.01kgf·m	280 QCK-A
DTC-5000REV-UW	5 ~ 50kgf·m	0.01kgf·m	700 QCK
DTC-10000REV-UW	10 ~ 100kgf·m	0.1kgf·m	1000 QCK
DTC-PI80REV-UW	8 ~ 80lbf·in	0.01lbf·in	12 QCK
DTC-PI400REV-UW	40 ~ 400lbf·in	0.1lbf·in	50 QCK
DTC-PI800REV-UW	80 ~ 800lbf·in	0.1lbf·in	100 QCK
DTC-PF100REV-UW	10 ~ 100lbf·ft	0.1lbf·ft	200 QCK
DTC-PF200REV-UW	20 ~ 200lbf·ft	0.1lbf·ft	280 QCK-A
DTC-PF400REV-UW	40 ~ 400lbf·ft	0.1lbf·ft	700 QCK
DTC-PF800REV-UW	80 ~ 800lbf·ft	1lbf·ft	1000 QCK

Dimensions of DTC-REV-UW are same as DTC-REV.

DTC-REV

Separate type

DATA OUTPUT DIGITAL TORQUE WRENCH

DATA OUTPUT DIGITAL TORQUE WRENCH

FEATURES

- Accuracy : $\pm 1\%$ of indicated value +1 increment, over full range
- Display : OLED
- Measuring mode : ①Peak hold ②Peak to Peak ③Tracking
- Measuring direction : CW / CCW changeover, provided with CW / CCW status display
- Power supply : Lithium-ion rechargeable battery 18650
100-240V battery charger
- Battery Life : Approx. 20 hours with fully charged battery. (continuous operation)
- Auto power-off : Approx. 30 minutes
- Tolerance setting : 1 to 10%. Automatic judgment for pre-set target torque
- Data input : 1000 data can be stored

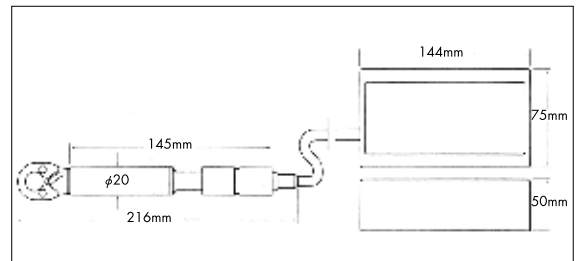

Model	Range (Unit)	Increment	Weight (kg)	Accessory
DTC-CN200REV	20~200 cN·m	0.1 cN·m	1	12QCK
DTC-CN500REV	50~500 cN·m	0.1 cN·m	1	12QCK
DTC-20REV	2~20 Kgf·cm	0.01 Kgf·cm	1	12QCK
DTC-50REV	5~50 Kgf·cm	0.01 Kgf·cm	1	12QCK
DTC-PI40REV	4~40 lbf·in	0.01 lbf·in	1	12QCK

DTDK-REV

DATA OUTPUT DIGITAL TORQUE DRIVER

Multi function data out put digital torque driver with OLED display.

FEATURES

- Accuracy : $\pm 1\%$ of indicated value +1 increment, over full range
- Display : OLED
- Measuring mode : ①Peak hold ②Peak to Peak ③Tracking
- Measuring direction : CW / CCW changeover, provided with CW / CCW status display
- Power supply : Lithium-ion rechargeable battery 18650
100-240V battery charger
- Battery Life : Approx. 20 hours with fully charged battery. (continuous operation)
- Auto power-off : Approx. 30 minutes
- Tolerance setting : 1 to 10%. Automatic judgment for pre-set target torque
- Data input : 1000 data can be stored

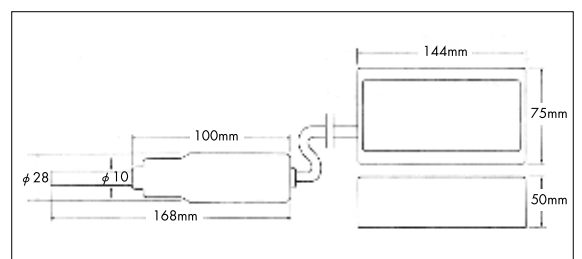

Model	Range (Unit)	Increment	Weight (kg)	Accessory
				Standard bits Phillips SB type
DTDK-CN200REV	20~200 cN·m	0.1 cN·m	1	No.0, No.1
DTDK-CN500REV	50~500 cN·m	0.1 cN·m	1	No.1, No.2
DTDK-20REV	2~20 Kgf·cm	0.01 Kgf·cm	1	No.0, No.1
DTDK-50REV	5~50 Kgf·cm	0.01 Kgf·cm	1	No.1, No.2
DTDK-PI40REV	4~40 lbf·in	0.01 lbf·in	1	No.1, No.2

LTDK CLUTCH RELEASE TORQUE SCREW DRIVERS

Clutch release prevents over-tightening, reduces fatigue.

FEATURES

- Comfortable grip for extended use.
- Light weight and short overall length facilitates jobs.
Sensitive clutch release helps the operator feel when the torque setting is reached.
- Set the required torque value and tighten, all operators tighten consistently.
- Two Phillips bit are included.
- Various hex and box drive bits are available.
- Use for clockwise tightening.
- Accuracy : $\pm 3\%$ of indicated value over the full range, clockwise.
- "H"-models accept standard bits instead of CB type bits.

USING AN LTDK DRIVER

- (1) Select and mount a bit to match the fastener.
- (2) Rotate the adjusting ring and set the desired torque.
- (3) Tighten the fastener clockwise until the clutch releases and there is no more resistance.



CN60~CN500LTDK

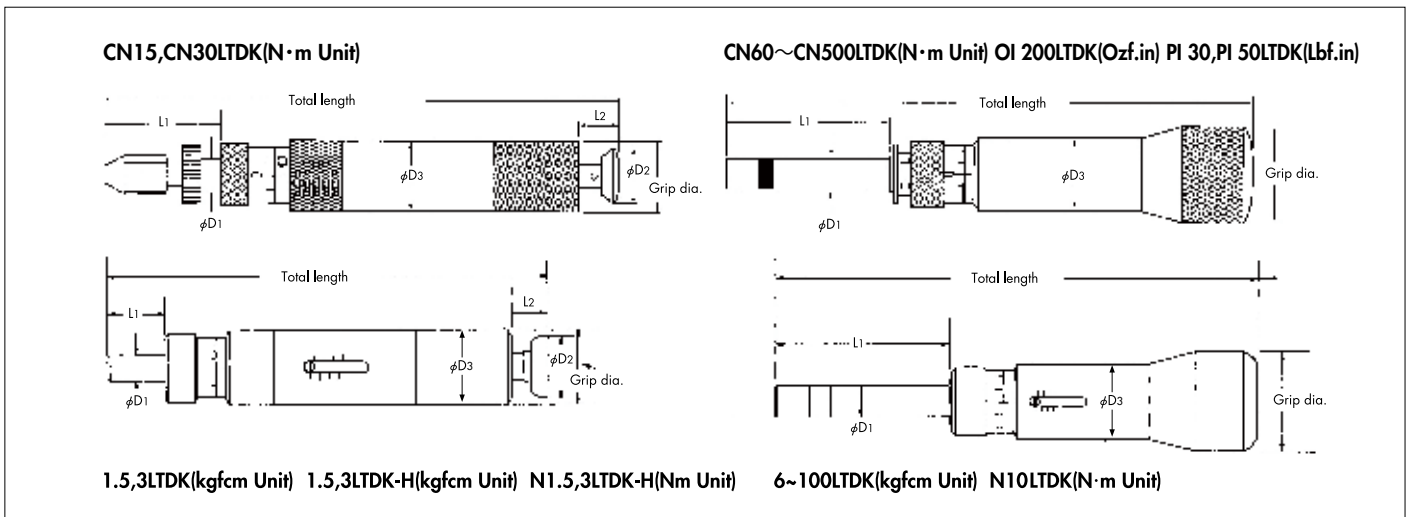

Old Model (cN·m/N·m)	New Model (cN·m/N·m)	Range	Increment	Model (ozf·in/lbf·in)	Range	Increment	Grip dia. φmm	Total length (without bit) mm	Dimensions (mm)					Weight g	Included Accessory		
									cN·m/N·m		ozf·in/lbf·in		Body				
									L1	L2	φD1	φD2	φD3	Phillips	Bit type	Included	
N1.5LTDK	CN15LTDK	1 ~ 15 cN·m	0.1 cN·m				16	107	22	10.5	5.5	14.4	15.5	57	No.0 No.1		KANON bits CB type
N3LTDK	CN30LTDK	2 ~ 30 "	0.2 "				25	110	26				20	99	No.0 No.1		
N6LTDK	CN60LTDK	5 ~ 60 "	0.5 "				30						192				No.0 No.1
N12LTDK	CN120LTDK	20 ~ 120 "	1 "	OI 200LTDK	40 ~ 200 ozf·in	1	34	157	51		10		214		No.1 No.2	Standard bits SB type	
N20LTDK	CN200LTDK	40 ~ 200 "	1 "				40	200	63				34	436			No.2, No.3
N30LTDK	CN300LTDK	40 ~ 300 "	1 "	PI 30LTDK	4 ~ 30 lbf·in	0.1	45	235	100		11		35	762	No.2, No.3		
N50LTDK	CN500LTDK	100 ~ 500 "	2.5 "	PI 50LTDK	10 ~ 50 "	0.25											No.0 No.1
N100LTDK	N10LTDK	4 ~ 10 N·m	0.05 N·m												No.0 No.1	Included	
N1.5LTDK-H	CN15LTDK-H	1 ~ 15 cN·m	0.1 cN·m				16	111	26	10.5	10	14.4	15.5	60			
N3LTDK-H	CN30LTDK-H	2 ~ 30 "	0.2 "														

* is the new model that is applied from 1st January, 2016.

Model (kgf·cm)	Range	Increment	Grip dia.	Total length (without bit)	Dimensions (mm)					Weight	Included Accessory		
					Body						Bits		Extension Bar
					L1	L2	φD1	φD2	φD3		g	Phillips	
1.5LTDK	0.1~1.5 kgf·cm	0.01 kgf·cm	16	99	14	10.5	5.5	14.4	15.5	50	No.0	KANON bits OB type	Included
3LTDK	0.2~3 //	0.02 //									No.1		
6LTDK	0.5~6 //	0.05 //	25	110	35	10	20	25	95	No.0	Standard bits SB type		
12LTDK	2~12 //	0.1 //								No.1			
20LTDK	4~20 //	0.1 //	34	157	57	11	34	436	208	No.2	Standard bits SB type		
30LTDK	4~30 //	0.1 //								No.3			
50LTDK	10~50 //	0.25 //	40	200	73	35	762	No.2, No.3					
100LTDK	40~100 //	0.5 //	45	235	100	60	No.0	No.1					
1.5LTDK-H	0.1~1.5 //	0.01 //	16	111	26	10.5	10	14.4	15.5	60	No.0	Standard bits SB type	
3LTDK-H	0.2~3 //	0.02 //									No.1		

STDK PRE-SET TORQUE DRIVERS

Clutch release prevents over tightening.



FEATURES

- A single function driver, used for a single torque setting.
- Most suited for tightening multiple same-size fasteners at the same torque in a production line.
- Setting confirmation unnecessary.
- Light weight and short overall length facilitates jobs.
Sensitive clutch release helps the operator feel when the torque setting is reached.
- All operators tighten consistently.
- Two Phillips bit are included.
- Various hex and box drive bits are available.
- Accuracy : ±3% of set value, cw, ccw
- * Please specify required set torque when you order.

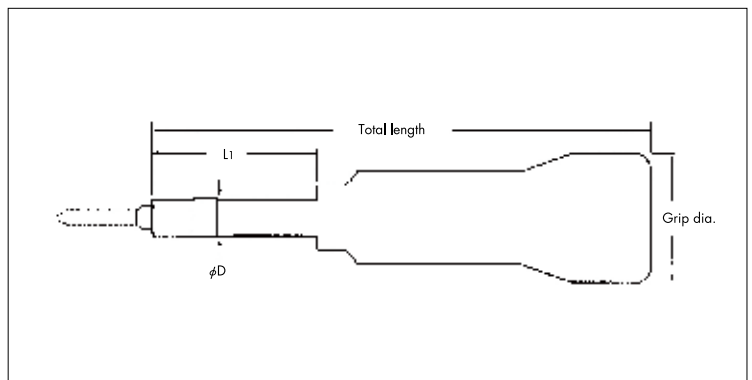

Model (kgf·cm)	Range	Old Model (cN·m/N·m)	New Model (cN·m/N·m)	Range	Model (ozf·in/lbf·in)	Range	Grip dia.	Total length (without bit)	Dimensions (mm)		Weight	Included Accessory		
									Body			Bits		Extension Bar
									L1	φD		g	Phillips	
1.5STDK	0.1~1.5	N1.5STDK	CN15STDK	1~15 cN·m	Ol 22STDK	2~22 ozf·in	16	92	22	8	45	No.0	KANON bits CB type	Included
3STDK	0.2~3	N3STDK	CN30STDK	2~30 //	Ol 44STDK	4~44 //						No.1		
6STDK	0.5~6	N6STDK	CN60STDK	5~60 //	Ol 80STDK	20~80 //	25	103	41	94	148	No.0	Standard bits SB type	
12STDK	2~12	N12STDK	CN120STDK	20~120 //	Ol 200STDK	40~200 //								
20STDK	4~20	N20STDK	CN200STDK	40~200 //	Pl 20STDK	4~20 lbf·in	30	116	54	10	170	No.1	Standard bits SB type	
30STDK	4~30	N30STDK	CN300STDK	40~300 //	Pl 30STDK	4~30 //								
50STDK	10~50	N50STDK	CN500STDK	100~500 //	Pl 50STDK	10~50 //	35	126	56	220	200	No.1	Standard bits SB type	
100STDK	40~100	N100STDK	CN100STDK	4~10 N·m	Pl 100STDK	40~100 //								
							45	248	246	11	790	No.2, No.3		

* is the new model that is applied from 1st January, 2016.

DPSK DIAL GAUGE TORQUE DRIVERS

Suited for light torque, general tightening work, inspections. Easy to handle, easy to read scale.

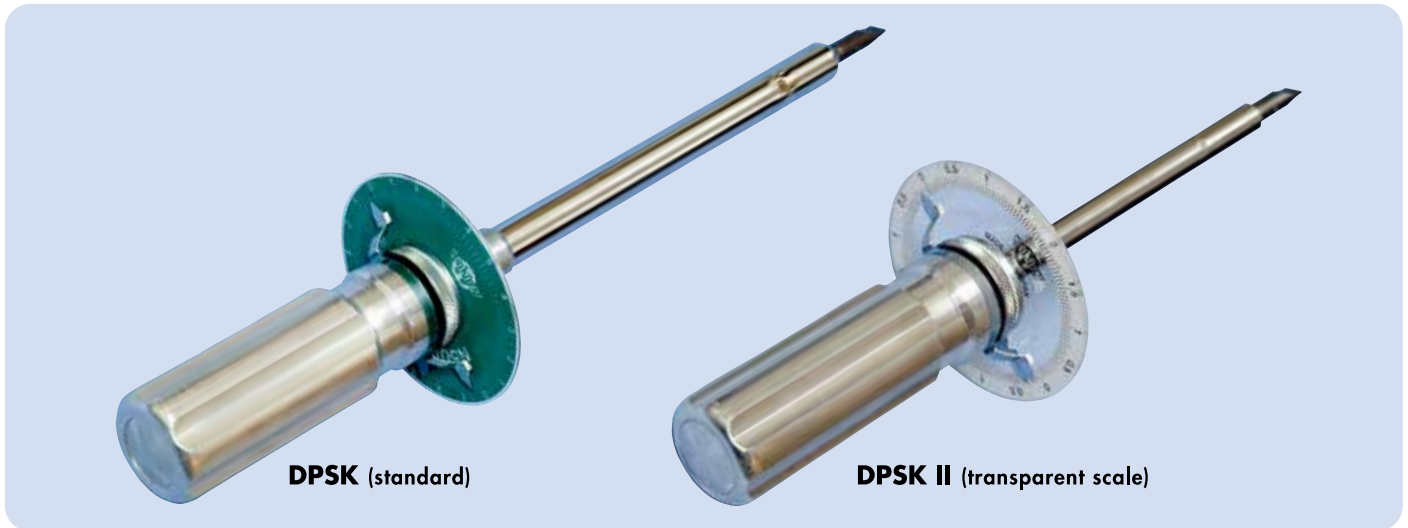

FEATURES

DPSK (standard)

- A light torque driver well suited for general tightening, inspections and break tests.
- Easy handling with a direct reading dial gauge.
- Use for both clockwise and counterclockwise tightening.
- Peak torque indicator works in both directions, too.
- Large, easily read dial gauge.

DPSK II (transparent scale)

- The transparent scale makes engaging the fastener easier.
- For both models, accuracy is $\pm 3\%$ of the indicated value over the full range

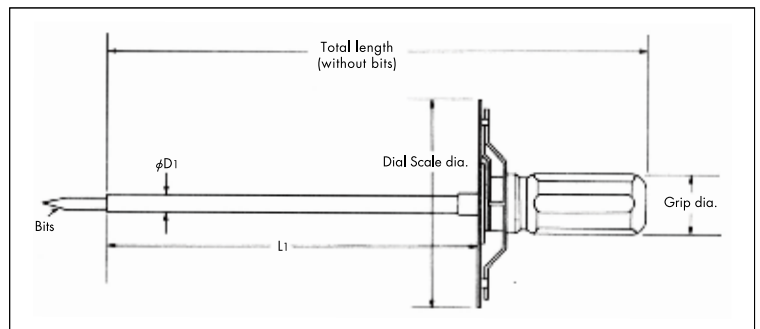

USING A DPSK DRIVER

- (1) Mount a bit matching the fastener being
- (2) Loosen the peak indicator ring.
- (3) Set the peak indicator to 0.
- (4) Tighten the fastener while observing the scale.

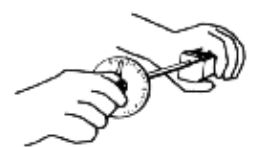
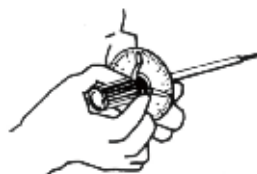

Model (kgf·cm)	Range (CW/CCW)	Increment	Old Model (cN·m/N·m)	New Model (cN·m/N·m)	Range (CW/CCW)	Increment	Dial dia.	Grip dia.	Total length (without bit)	Dimensions (mm)		Weight	Included Accessory Bits	
										Driver shaft(mm)	Weight		Phillips	Bit type
1DPSK-H	0.2~1	0.025	N 1DPSK	CN 10DPSK-H	2~10 cN·m	0.25 cN·m	78	21	260	152	6	0.12	No.0 No.1	Standard bits SB type
2DPSK-H	0.5~2	0.05	N 2DPSK	CN 20DPSK-H	5~20 "	0.5 "			252	148				
5DPSK-H	1~5	0.2	N 5DPSK	CN 50DPSK-H	10~50 "	2 "			255	150				
10DPSK	2~10	0.2	N 10DPSK	CN 100DPSK	20~100 "	2 "			222	130				
20DPSK	5~20	0.5	N 20DPSK	CN 200DPSK	50~200 "	5 "	242	130	12	0.36				
50DPSK	10~50	2	N 50DPSK	CN 500DPSK	100~500 "	20 "	36	300	188	14	0.47	No.1 No.2		
10DPSK(II)	2~10	0.2	N 10DPSK(II)	CN 100DPSK-L	20~100 cN·m	2 cN·m	222	130	12	0.29				
20DPSK(II)	5~20	0.5	N 20DPSK(II)	CN 200DPSK-L	50~200 "	5 "	242	130	12	0.32				
50DPSK(II)	10~50	2	N 50DPSK(II)	CN 500DPSK-L	100~500 "	20 "	36	300	188	14	0.42			

* is the new model that is applied from 1st January, 2016.

SGK TORQUE GAUGES

Capable of accurately measuring very low torque values.

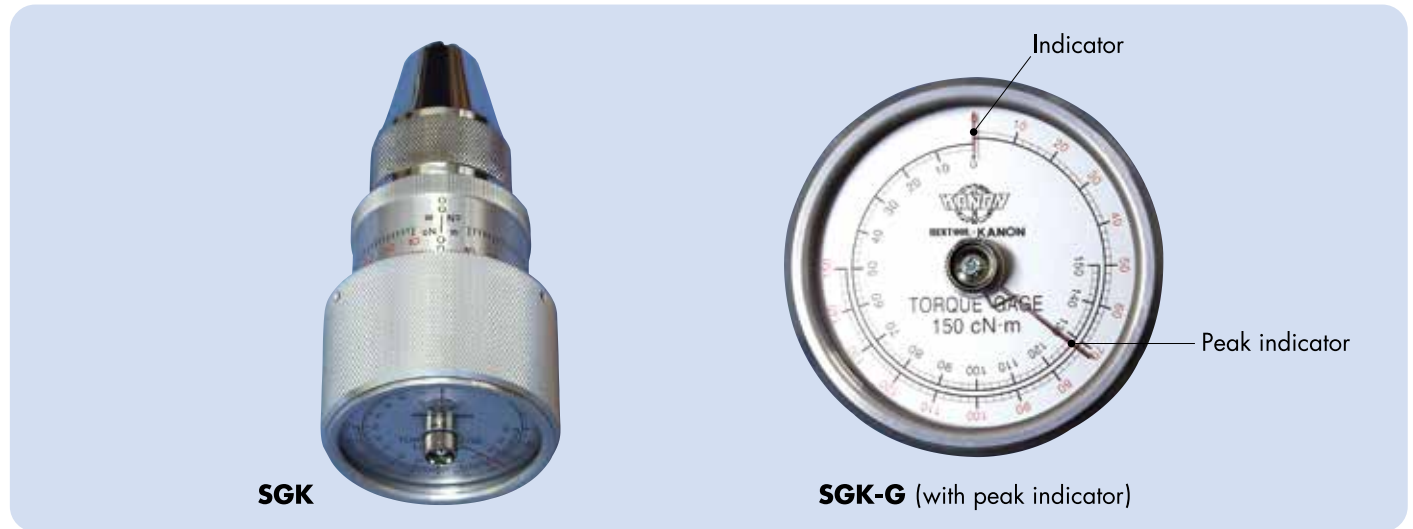

* Peak indicator is optional

FEATURES

- Due to their miniature design and light weight, these gauges are convenient and easy to carry.
- A three part chuck with knurled surface enables firmly gripping even odd shapes.
- The inset scale face helps avoid incidental damage.
- The gauges measure clockwise and counterclockwise.
- With scales on the sides and the face, torque readings can be obtained either way.
- Accuracy : $\pm 6\%$ of the indicated value over the full range

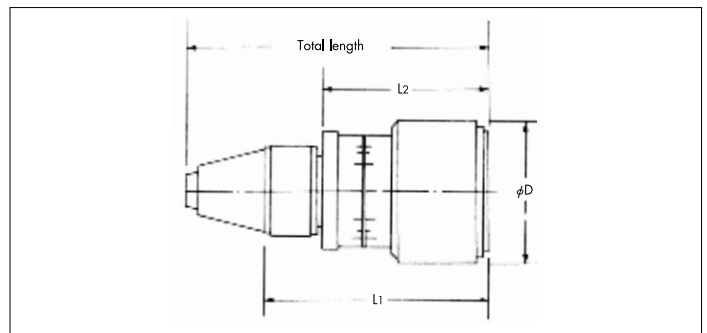

USING AN SGK GAUGE

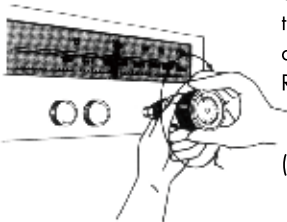

Starting torque can be measured with the chuck gripping a knob or shaft of an electronic device.
Rotate clockwise or counterclockwise.

(Rotate CW or CCW)



- If you would like SGK with a peak indicator, please specify "SGK-G" on your purchase order.
ex) CN150SGK-G

Three part chuck

Model (gf·cm/kgf·cm)	Range (CW/CCW)	Increment	Old Model (mN·m/cN·m)	New Model (mN·m/cN·m)	Range (CW/CCW)	Increment	Chucking dia.	Total length	Dimensions (mm)			Weight
									Grip dia.	Total length (without chuck)		
		gf·cm/kgf·cm			mN·m/cN·m		φ mm	mm	φ D	L ₁	L ₂	
90(I)SGK	10 ~ 90	2	N90(I)SGK	MN95GK	1 ~ 9	0.2	1 ~ 6.5	106	43	81	57.5	0.29
150(I)SGK	20 ~ 150	2	N150(I)SGK	MN155GK	2 ~ 15	0.2						
300(I)SGK	40 ~ 300	5	N300(I)SGK	MN305GK	4 ~ 30	0.5						
600(I)SGK	50 ~ 600	10	N600(I)SGK	MN605GK	5 ~ 60	1						
1200(I)SGK	100 ~ 1,200	20	N1200(I)SGK	MN1205GK	10 ~ 120	2						
2400(I)SGK	200 ~ 2,400	50	N2400(I)SGK	MN2405GK	20 ~ 240	5						
1.5(II)SGK	0.1 ~ 1.5	0.02	N1.5(II)SGK	CN155GK	1 ~ 15	0.2	1 ~ 8.5	134	63	100	73	0.6
2.4(II)SGK	0.2 ~ 2.4	0.02	N2.4(II)SGK	CN245GK	2 ~ 24	0.2						
3.6(II)SGK	0.4 ~ 3.6	0.05	N3.6(II)SGK	CN365GK	4 ~ 36	0.5						
6(II)SGK	0.5 ~ 6	0.1	N6(II)SGK	CN605GK	5 ~ 60	1						
9(II)SGK	1 ~ 9	0.2	N9(II)SGK	CN905GK	10 ~ 90	2						
15(II)SGK	1 ~ 15	0.2	N15(II)SGK	CN1505GK	10 ~ 150	2						

* is the new model that is applied from 1st January, 2016.

KDTA-GT-UC

DIGITAL TORQUE ANALYZERS

Enhanced digital processor system. Provides high performance with digital wrenches.

FEATURES

- LCD display eliminates reading errors.
- Processor chip assures measurement with high reliability and accuracy.
- The display unit angle can be adjusted approximately 70°.
- Saves time and helps speed up work.
- Equipped with a kgf·cm/N·m selector switch.
- Operator can set min/max percentage parameters from 0–10%.
- Analyzer can indicate in or out of specification with pass or fail displayed.

SPECIFICATIONS

- Power source : AC100-240V 50/60Hz
- Accuracy : ±1% of the indicated value +1 increment, over the full range
- Display : LCD (character height : 25mm)
- Operating temperature : 5~35°C



KDTA-N20GT-UC

Model	Range(CW/CCW)	Increment	English Model	Range(CW/CCW)	Increment	Measuring mode	Dimensions (mm)			Drive size mm	Weight kg	Included Accessory
	kgf·cm/kgf·m	N·m		lbf·in	N·m		Overall depth	Overall width	Overall height			
KDTA-N2GT-UC	2 ~ 20	0.01 kgf·cm	KDTA-N2GT-PI	1.77 ~ 17.70	0.01 lbf·in	TRACK Peak hold Peak to peak hold	120	250	251	12	6	6.35×12 9.5×12 Socket
	20 ~ 200	0.1 cN·m		20 ~ 200	0.1 cN·m							
KDTA-N10GT-UC	10 ~ 100	0.1 kgf·cm	KDTA-N10GT-PI	8.9 ~ 88.0	0.1 lbf·in							
	1 ~ 10	0.01 N·m		1 ~ 10	0.01 N·m							
KDTA-N20GT-UC	20 ~ 200	0.1 kgf·cm	KDTA-N20GT-PI	17.7 ~ 177.0	0.1 lbf·in		220	380	272	26	25	19.05×26 12.7×26 Socket
	2 ~ 20	0.01 N·m		2 ~ 20	0.01 N·m							
KDTA-N100GT-UC	100 ~ 1000	1 kgf·cm	KDTA-N100GT-PI	89 ~ 880	1 lbf·in	30				30	25	30
	10 ~ 100	0.1 N·m		10 ~ 100	0.1 N·m							
KDTA-N200GT-UC	200 ~ 2000	1 kgf·cm	KDTA-N200GT-PI	177 ~ 1770	1 lbf·in							
	20 ~ 200	0.1 N·m		20 ~ 200	0.1 N·m							
KDTA-N600GT-UC	600 ~ 6000	1 kgf·cm	KDTA-N600GT-PF	44.3 ~ 442.0	0.1 lbf·ft							
	60 ~ 600	0.1 N·m		60 ~ 600	0.1 N·m							
KDTA-N1000GT-UC	10 ~ 100	0.1 kgf·cm	KDTA-N1000GT-PF	74 ~ 737	1 lbf·ft							
	100 ~ 1000	1 N·m		100 ~ 1000	1 N·m							



KDTA-GTH-UC

LARGE DIGITAL TORQUE ANALYZERS



KDTA-N20GTH-UC

FEATURES

- LCD display eliminates reading errors.
- Processor chip assures measurement with high reliability and accuracy.
- The display unit angle can be adjusted approximately 70°.
- Saves time and helps speed up work.
- Equipped with a kgf·cm/N·m selector switch.

SPECIFICATIONS

- Power : AC100-240V 50/60Hz
- Accuracy : ±1% of the indicated value +1 increment, over the full range
- Display : LCD (character height : 25mm)
- Operating temperature range : 5~35°C

Model	Range(CW/CCW)		Increment	English Model	Range(CW/CCW)		Increment	Measuring mode	Dimensions (mm)			Drive size	Weight	Included Accessory
	kgf·cm/kgf·m				lbf·in/lbf·ft				Overall depth	Overall width	Overall height			
KDTA-N20GTH-UC	20 ~ 200	kgf·cm	0.1	KDTA-N20GTH-PI	17.7 ~ 177.0	lbf·in	0.1	TRACK Peak hold Peak to peak hold	340	220	169	12	12	6.35×12 Socket 9.5×12 Socket
	2 ~ 20	N·m	0.01		2 ~ 20	N·m	0.01		240	14				
KDTA-N100GTH-UC	100 ~ 1000	kgf·cm	1	KDTA-N100GTH-PI	89 ~ 880	lbf·in	1		540	280	240	14	18	9.5×14 Socket 12.7×14 Socket
	10 ~ 100	N·m	0.1		10 ~ 100	N·m	0.1		603	310				
KDTA-N200GTH-UC	200 ~ 2000	kgf·cm	1	KDTA-N200GTH-PI	177 ~ 1770	lbf·in	1		780	362	285	22	40	12.7×22 Socket 19.05×22 Socket
	20 ~ 200	N·m	0.1		20 ~ 200	N·m	0.1							
KDTA-N300GTH-UC	300 ~ 3000	kgf·cm	1	KDTA-N300GTH-PF	22.2 ~ 221.0	lbf·ft	0.1		1300	490	415	26	92	12.7×26 Socket 19.05×26 Socket
	30 ~ 300	N·m	0.1		30 ~ 300	N·m	0.1	30						
KDTA-N600GTH-UC	600 ~ 6000	kgf·cm	1	KDTA-N600GTH-PF	44.3 ~ 442.0	lbf·ft	0.1	1668	556	415	30	59	12.7×30, 19.05×30 25.4×30 Socket	
	60 ~ 600	N·m	0.1		60 ~ 600	N·m	0.1							74 ~ 737

DRIVE ATTACHMENTS (Optional)

■ KDTA-N2GT-UC/N10GT-UC N20GT-UC/KDTA-N20GTH-UC

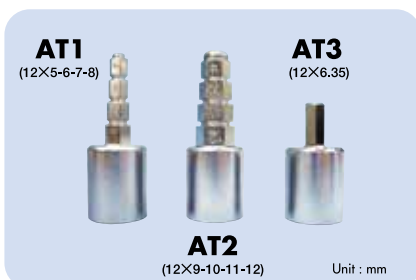

■ KDTA-N100GT-UC/KDTA-N200GT-UC KDTA-N100GTH-UC/KDTA-N200GTH-UC KDTA-N200GTS-UC



■ KDTA-N300GTH-UC



KDTA-GTS-UC

DIGITAL TORQUE ANALYZERS

Highly accurate and economical torque analyzer, easy for operators to use on the job site.



FEATURES

- LCD display eliminates reading errors.
- Processor chip assures measurement with high reliability and accuracy.
- Saves time and helps speed up work.
- Equipped with a kgf·cm/N·m selector switch.

SPECIFICATIONS

- Power : AC100-240V 50/60Hz
- Accuracy : $\pm 1\%$ of the indicated value +1 increment, over the full range
- Display : LCD (character height : 25mm)
- Operating temperature range : 5~35°C

Model	Range (CW/CCW)		Increment		Measuring mode	Unit conversion	Dimensions (mm)			Drive size mm	Weight kg	Included Accessory
	gf·cm/kgf·m		N·m				Overall depth	Overall width	Overall height			
	50 ~ 2000	1	kgf·cm	1						kgf·cm		
KDTA-N200GTS-UC	50 ~ 2000	1	kgf·cm	1	TRACK Peak hold Peak to peak hold	kgf·cm N·m	260	200	200	14	10	9.5 × 14 12.7 × 14 Socket
KDTA-N200GTS-PI	45 ~ 1770	1	lbf·in	1								

DRT

KANON TORQUE MEASUREMENT MULTI-INDICATOR

Model DRT multi-indicator handles 16 different types of work.
The TEDS-based smart indicator is designed for accurate and speedy analysis of bolt-tightening.



Click type torque wrench for DRT

Model	Range
DRT-N50DR	10 ~ 50Nm
DRT-N100DR	20 ~ 100Nm
DRT-N200DR	40 ~ 200Nm



Non-click torque wrench for DRT

Model	Range
DRT-N40DTC	4 ~ 40Nm
DRT-N100DTC	10 ~ 100Nm
DRT-N200DTC	20 ~ 200Nm



Torque Driver for DRT

Model	Range
DRT-CN500DTDK	100 ~ 500cNm



Load cell for DRT

Model	Range
DRT-N2KDIA	0.2 ~ 2Nm
DRT-N20KDIA	2 ~ 20Nm
DRT-N200KDIA	20 ~ 200Nm

FEATURES

- Tools are easily exchanged and calibrated. A sensor with built-in TEDS information is directly connected to a tool for automatic reading of necessary information, eliminating troublesome calibration each time a tool is exchanged (IEEE 1451.4, Class 2 mixed mode interfaced).
- Various tools can be used, including click type and non-click type torque wrench and strain gauge sensors.
- Torque values remain in waveforms, allowing the user to view torque in any desired place.
- Bolt-tightening is analyzed in a short time: Tightening, Loosening inspection, Re-tightening inspection, Torque wrench inspection, Destructive inspection

TEDS-based multi-indicating system (Examples)

Torque wrench with sensor for operation



Torque sensor



Torque wrench with sensor for inspection



* Sensors are built to order.

**Multi-indicator
DRT**



Data collection

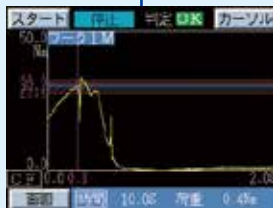

Torque is displayed in waveforms.



Judgment (an example of pass)



Judgment (an example of rejection)

* English version is also available

<Specifications>

Model	DRT	
Display/controller	3.5 type STN color LCD (320 x 240 dots)	
Operation screen	Controller	Touch panel
	Display range	0 to ±9999
	Decimal point position	Arbitrarily selected
	Display change frequency	3 times/s
	Time axis	0.1 to 99.9s
Setting	Comparative judgment values Load value: upper limit, lower limit, upper-upper limit, and lower-lower limit	
Function	Hold function	Inflection point, sample, peak, maximal and minimal hold
	Clock function	Data is controlled and saved according to real-time clock.
Data output	RS-232C, CF card	
Power supply	AC 100 to 240V	
Operating temperature range	0 to +40°C	
Weight	2.8kg	
Dimensions	107 (W) x 140 (H) x 257 (D) mm	
Applicable standards	EMC	VCCI 1 (Class A), EN55011 (Class A), EN61326-4-2, 3, 4, 5, 6, 8, 11, EN61000-3-2, 3
	Safety standards	EN61010-1



**Dr. Torque
Multi-indicator DRT**

Torque Measurement
Multi-indicator

KDTA-DH

DIGITAL TORQUE ANALYZERS FOR TORQUE DRIVERS



KDTA-8DH

KDTA-8DH / KDTA-80DH

FEATURES

- Designed for LTK and STDK
- Battery powered
- Battery Charger is available for AC 100V~240V 50/60Hz
- Lightweight plastic case
- kgf·cm/N·m / lbf·in unit conversion
- MODE : TRACK (constantly indicates torque value.)
PEAK HOLD
PEAK TO PEAK-HOLD
- AUTO RESET : Timer function available
- DATA OUTPUT : Digital output
- Accuracy : $\pm 1\%$ of the indicated value +1 increment, over the full range

Model	Range	Increment	Measuring mode	Battery	Size	Weight (kg)
KDTA-8DH	3~800mN·m 0.03~8kgf·cm 0.03~7lbf·in	0.1mN·m 0.001kgf·cm 0.001lbf·in	RUN Peak hold Peak to Peak hold	Rechargeable	230 (W) × 123 (D) × 65 (H) mm	1.8
KDTA-80DH	3~800cN·m 0.3~80kgf·cm 0.3~70lbf·in	0.1cN·m 0.01kgf·cm 0.01lbf·in	RUN Peak hold Peak to Peak hold	Rechargeable	230 (W) × 123 (D) × 65 (H) mm	1.8

KDTA-D

DIGITAL TORQUE ANALYZERS FOR ELECTRIC DRIVERS

KDTA-10D / KDTA-100D

FEATURES

- Battery is rechargeable.
- For any brand of the Electric Driver
- Battery Charger is available for AC 100V~240V 50/60Hz
- MODE : TRACK (constantly indicates torque value.)
PEAK HOLD
PEAK TO PEAK-HOLD
- AUTO RESET : Timer function available
- DATA OUTPUT : Digital output
- Accuracy : $\pm 1\%$ of the indicated value +1 increment, over the full range



Model	Range	Increment	Measuring mode	Battery	Size	Weight (kg)
KDTA-10D	1.5~100.0cN·m 0.15~10.00kgf·cm 0.13~10.00lbf·in	0.1cN·m 0.01kgf·cm 0.01lbf·in	RUN Peak hold Peak to Peak hold	Rechargeable	230 (W) × 123 (D) × 65 (H) mm	1.18
KDTA-100D	15~1000cN·m 1.5~100.0kgf·cm 1.3~100.0lbf·in	1cN·m 0.1kgf·cm 0.1lbf·in	RUN Peak hold Peak to Peak hold	Rechargeable	230 (W) × 123 (D) × 65 (H) mm	1.18

TK TENSION GAUGES

Demonstrating KANON's measuring versatility.
Great performance whether measuring vertically or horizontally.

FEATURES

- Measures pushing, pulling force and spring tension.
Our tension gauges are designed to indicate precise increments of force.
- Use the gauges for taking horizontal measurements. Just add the correcting value to the indicated value (see the table below). A peak indicator is available for TK500 to TK30000 and TK500CN to TK30000CN.
- Accuracy : ± 1 increment

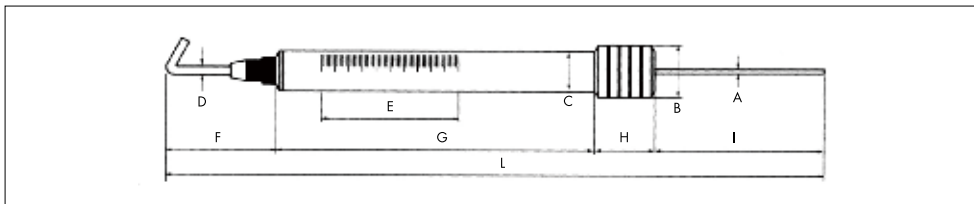

Model (g)	Range (g)	Incr. (g)	A mm	B mm	C mm	D mm	E mm	F mm	G mm	H mm	I mm	L mm	Weight (g)	Correcting value for horizontal measurements (g)
TK10	0 ~ 10	0.5	1.5	16	13	1.5	40	19	98	15	48	181	30	3
TK30	0 ~ 30	1	1.5	16	13	1.5	60	19	113	15	66	214	30	3
TK50	0 ~ 50	1	1.5	16	13	1.5	60	19	113	15	66	214	30	3
TK110	0 ~ 110	2	2	16	13	2	60	27.5	113	15	65.5	221	35	10
TK200	0 ~ 200	5	2	16	13	2	60	27.5	113	15	65.5	221	35	10
TK300	0 ~ 300	5	2	16	13	2	60	27.5	113	15	65.5	221	35	10
TK500	0 ~ 500	10	3	20	16	2.6	56	43	131	25	69	270	78	30
TK600	0 ~ 600	20	3	20	16	2.6	56	43	131	25	69	270	78	30
TK1000	0 ~ 1000	25	3	20	16	2.6	56	43	131	25	69	270	78	30
TK1500	0 ~ 1500	50	3	20	16	2.6	56	43	131	25	69	270	78	30
TK2000	0 ~ 2000	50	3	20	16	2.6	56	43	131	25	69	270	78	30
TK2500	0 ~ 2500	50	3	20	16	2.6	62	43	143	25	74	288	85	50
TK3000	0 ~ 3000	50	3	20	16	2.6	62	43	143	25	74	288	85	50
TK4000	0 ~ 4000	50	4	25	22	3.5	68	43	178	35	82	340	200	100
TK5000	0 ~ 5000	100	4	25	22	3.5	68	43	178	35	82	340	200	100
TK7000	0 ~ 7000	200	4	25	22	3.5	68	43	178	35	82	340	205	100
TK10000	0 ~ 10000	200	4	25	22	3.5	68	43	178	35	82	340	205	100
TK15000	0 ~ 15000	200	8	35	32	7	95	83	230	35	145	462	600	250
TK20000	0 ~ 20000	200	8	35	32	7	118	83	280	35	140	540	680	250
TK30000	0 ~ 30000	500	8	40	38	7	130	83	305	35	172	598	830	350

Model (cN)	Range (cN)	Incr. (cN)	A mm	B mm	C mm	D mm	E mm	F mm	G mm	H mm	I mm	L mm	Weight (g)	Correcting value for horizontal measurements (c-N)
TK10CN	0 ~ 10	0.5	1.5	16	13	1.5	40	19	98	15	48	181	30	3
TK30CN	0 ~ 30	1	1.5	16	13	1.5	60	19	113	15	66	214	30	3
TK50CN	0 ~ 50	1	1.5	16	13	1.5	60	19	113	15	66	214	30	3
TK110CN	0 ~ 110	2	2	16	13	2	60	27.5	113	15	65.5	221	35	10
TK200CN	0 ~ 200	5	2	16	13	2	60	27.5	113	15	65.5	221	35	10
TK300CN	0 ~ 300	5	2	16	13	2	60	27.5	113	15	65.5	221	35	10
TK500CN	0 ~ 500	10	3	20	16	2.6	56	43	131	25	69	270	78	30
TK600CN	0 ~ 600	20	3	20	16	2.6	56	43	131	25	69	270	78	30
TK1000CN	0 ~ 1000	25	3	20	16	2.6	56	43	131	25	69	270	78	30
TK1500CN	0 ~ 1500	50	3	20	16	2.6	56	43	131	25	69	270	78	30
TK2000CN	0 ~ 2000	50	3	20	16	2.6	56	43	131	25	69	270	78	30
TK2500CN	0 ~ 2500	50	3	20	16	2.6	62	43	143	25	74	288	85	50
TK3000CN	0 ~ 3000	50	3	20	16	2.6	62	43	143	25	74	288	85	50
TK4000CN	0 ~ 4000	50	4	25	22	3.5	68	43	178	35	82	340	200	100
TK5000CN	0 ~ 5000	100	4	25	22	3.5	68	43	178	35	82	340	200	100
TK7000CN	0 ~ 7000	200	4	25	22	3.5	68	43	178	35	82	340	205	100
TK10000CN	0 ~ 10000	200	4	25	22	3.5	68	43	178	35	82	340	205	100
TK15000CN	0 ~ 15000	200	8	35	32	7	95	83	230	35	145	462	600	250
TK20000CN	0 ~ 20000	200	8	35	32	7	118	83	280	35	140	540	680	250
TK30000CN	0 ~ 30000	500	8	40	38	7	130	83	305	35	172	598	830	350



- If you take a measurement horizontally, add the correcting value to the indicated measurement value per the table.

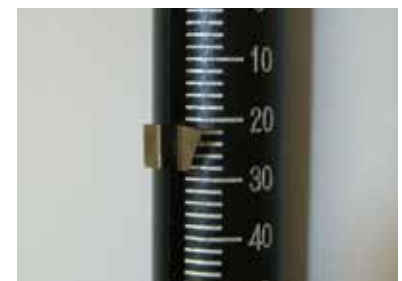





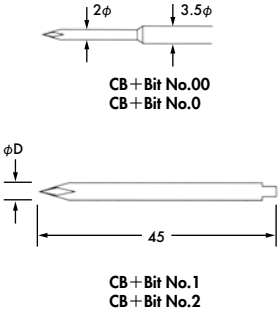
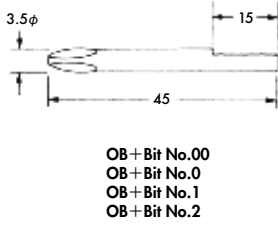
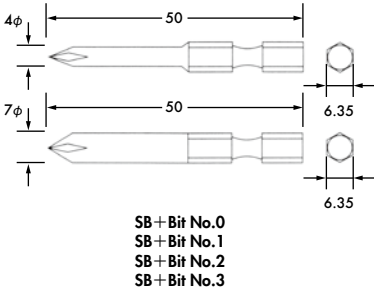

* Peak indicator is optional

- If you would like your TK gauge with a peak indicator, please specify "TK-G" on your purchase order.
ex). TK500CN-G

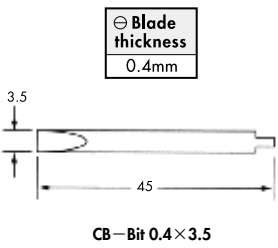
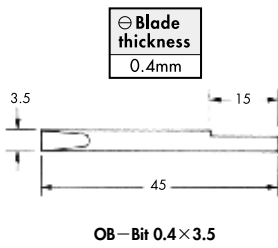
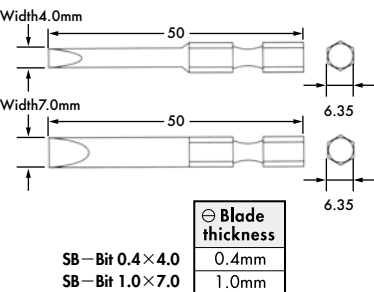
BITS

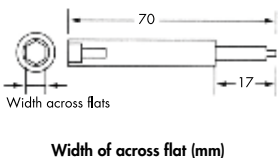
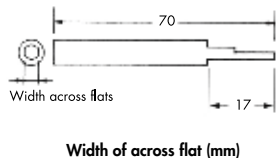
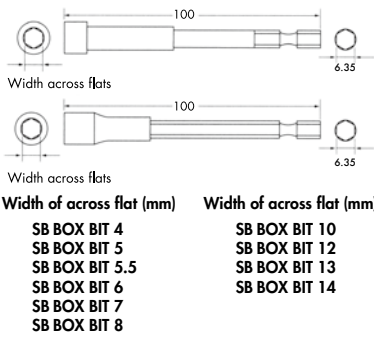
BITS FOR TORQUE DRIVERS

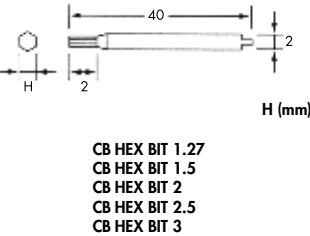
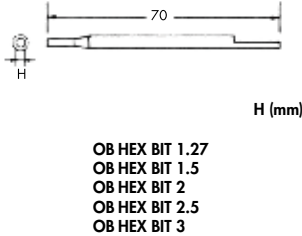
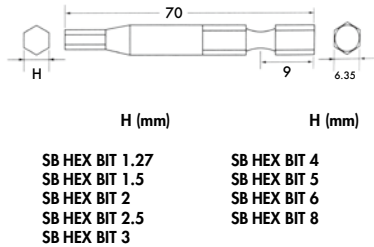
Type	CB type (KANON original)	OB type (KANON original)	SB type (Standard)
Applicable driver	CN15,CN30LTDK CN15,CN30STDK	1.5LTDK,3LTDK	CN60,120,200,300,500LTDK,N10LTDK CN15,30LTDK-H,1.5,3LTDK-H 6,12,20,30,50,100LTDK CN60,120,200,300,500STDK,N10STDK 6,12,20,30,50,100STDK CN100,200,500DPSK,CN100,200,500DPSK-L 10,20,50DPSK,10,20,50DPSK-II CN10,20,50DPSK-H,1,2,5DPSK-H
 Phillips	 <p>CB+Bit No.00 CB+Bit No.0</p> <p>CB+Bit No.1 CB+Bit No.2</p>	 <p>OB+Bit No.00 OB+Bit No.0 OB+Bit No.1 OB+Bit No.2</p>	 <p>SB+Bit No.0 SB+Bit No.1 SB+Bit No.2 SB+Bit No.3</p>
 Slot Drive	 <p>CB-Bit 0.4×3.5</p>	 <p>OB-Bit 0.4×3.5</p>	 <p>SB-Bit 0.4×4.0 SB-Bit 1.0×7.0</p>
 BOX BITS (Female type)	 <p>Width of across flat (mm)</p> <p>CB BOX BIT 3 CB BOX BIT 4 CB BOX BIT 5 CB BOX BIT 5.5 CB BOX BIT 6</p>	 <p>Width of across flat (mm)</p> <p>OB BOX BIT 3 OB BOX BIT 4 OB BOX BIT 5 OB BOX BIT 5.5 OB BOX BIT 6</p>	 <p>Width of across flat (mm)</p> <p>SB BOX BIT 4 SB BOX BIT 5 SB BOX BIT 5.5 SB BOX BIT 6 SB BOX BIT 7 SB BOX BIT 8</p> <p>SB BOX BIT 10 SB BOX BIT 12 SB BOX BIT 13 SB BOX BIT 14</p>
 HEX BITS (Male type)	 <p>H (mm)</p> <p>CB HEX BIT 1.27 CB HEX BIT 1.5 CB HEX BIT 2 CB HEX BIT 2.5 CB HEX BIT 3</p>	 <p>H (mm)</p> <p>OB HEX BIT 1.27 OB HEX BIT 1.5 OB HEX BIT 2 OB HEX BIT 2.5 OB HEX BIT 3</p>	 <p>H (mm)</p> <p>SB HEX BIT 1.27 SB HEX BIT 1.5 SB HEX BIT 2 SB HEX BIT 2.5 SB HEX BIT 3</p> <p>SB HEX BIT 4 SB HEX BIT 5 SB HEX BIT 6 SB HEX BIT 8</p>

PARTS FOR QLK, QSPK AND QCK

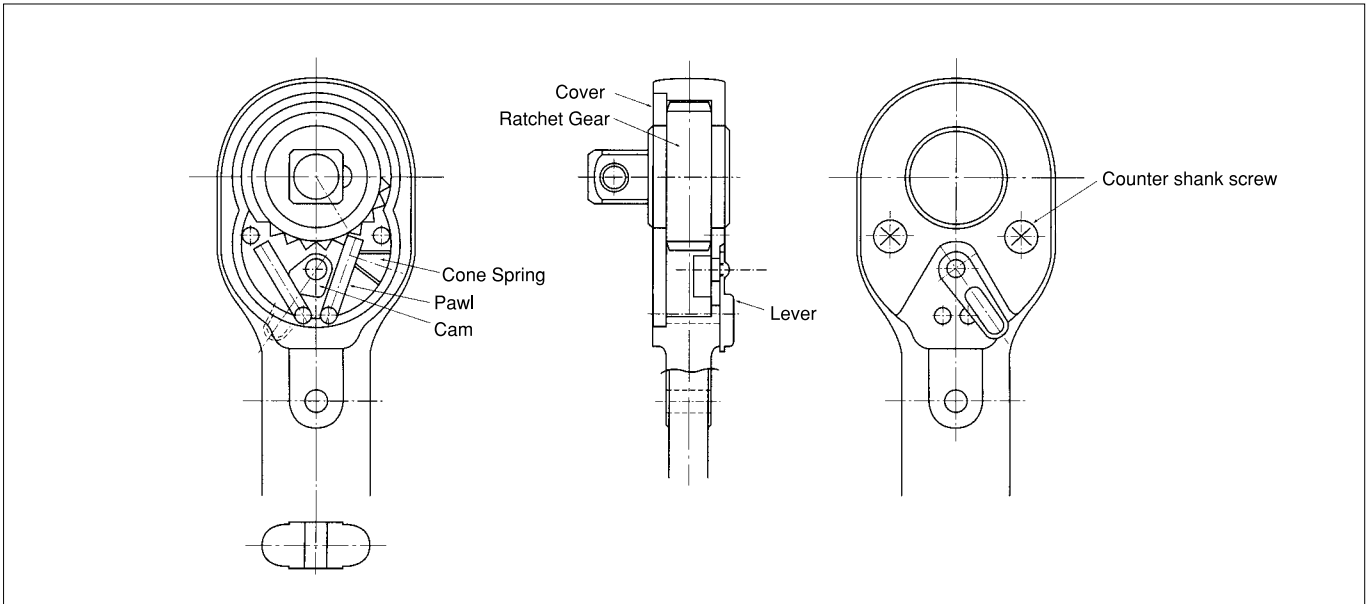

CAUTION FOR USE

CONFORM TO ITEMS AS SHOWN BELOW, AND ADEQUATELY HANDLE THE TORQUE WRENCH.

- 1** When bolts are tightened, it is dangerous to insert the pipe in the handle. Furthermore, an adequate tightening torque value can not be obtained.
- 2** If the extension tool is applied to the torque meter, a torque value indicated in the dial does not mean a torque value which is actually imposed on the bolt. (See Fig. 1)
The torque value should be calculated as follows.

$$T = \frac{A+B}{A} \times T_1$$

Where T=force which is actually imposed on bolts.

T₁=indication value of meter.

A=effective length of the body.

B=effective length of extension tool.

- 3** When bolts and nuts are tightened, the grasping position shall be at the center of the knurled zone, and tightening should be performed. (See Fig. 2)

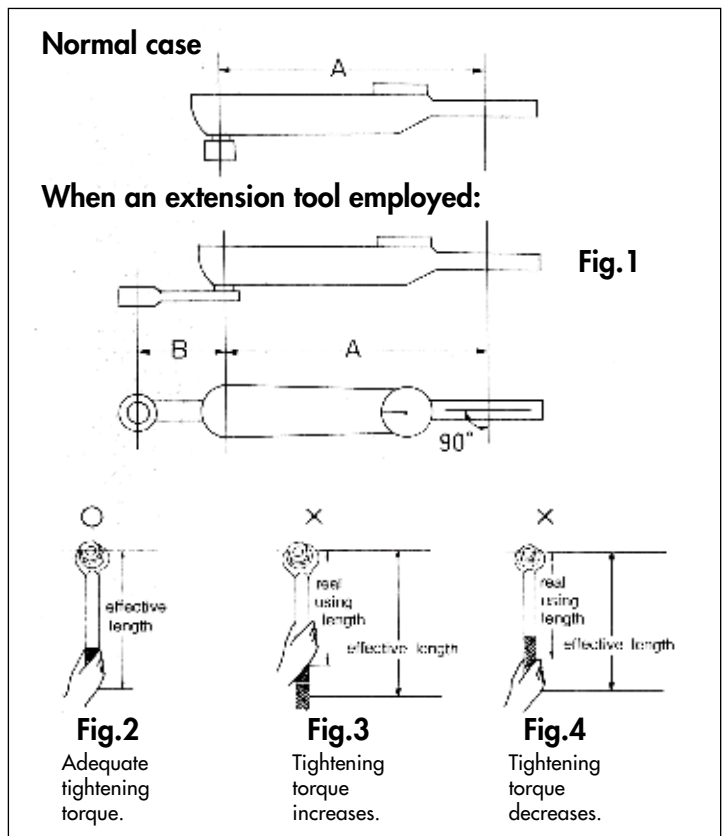

Bolt tightening torque table

Bolt width across flats (mm)			Bolt screw nominal dia.	Reference standard tightening torque $\frac{\text{kgf}\cdot\text{cm}}{\text{Nm}}$			
hexagon head bolt	set screw	hexagon socket head cap screw		Standard Bolt	7T,8T (high ten.)	10T,11T (high ten.) friction connection	Brass
4	(0.9)	(1.5)	M2	1.5 0.15	2.7 0.26	3.6 0.35	0.8 0.08
4.5	(1.27)	(2)	M2.5	3.2 0.31	5.8 0.57	7.7 0.76	1.6 0.16
5.5	1.5	2.5	M3	6 0.59	10.8 1.06	15 1.47	3 0.29
6	—	—	(M3.5)	10 0.98	18 1.77	24 2.35	5 0.49
7	2	3	M4	16 1.57	28 2.75	30 2.94	8 0.78
8	—	—	(M4.5)	21 2.06	38 3.73	50 4.9	11 1.08
8	2.5	4	M5	30 2.94	54 5.30	72 7.06	15 1.47
10	3	5	M6	50 4.9	90 8.83	120 11.77	25 2.45
11	—	—	(M7)	90 8.83	160 15.69	220 21.57	45 4.41
13	4	6	M8	120 11.77	220 21.57	290 28.44	60 5.88
17	5	8	M10	240 23.54	430 42.17	580 56.88	120 11.77
19	6	10	M12	420 41.19	760 74.53	1,000 98.07	210 20.59
22	6	12	(M14)	690 67.67	1,240 121.6	1,650 161.8	350 34.32
24	8	14	M16	1,080 105.9	2,000 196.1	2,600 255	540 52.96
27	8	14	(M18)	1,500 147.1	2,700 264.8	3,600 353	750 73.55
30	10	17	M20	2,100 205.9	3,800 372.7	5,100 500.1	1,050 103
32	—	17	(M22)	2,800 274.6	5,100 500.1	6,700 657	1,400 137.3
36	—	19	M24	3,400 333.4	6,100 598.2	8,200 804.1	1,700 166.7
41	—	19	(M27)	5,400 529.6	9,700 951.2	13,000 1,275	2,700 264.8
46	—	22	M30	7,200 706.1	13,000 1,275	17,300 1,697	3,600 353
50	—	24	(M33)	10,000 980.7	18,000 1,765	24,000 2,354	5,000 490.3
55	—	27	M36	13,000 1,275	23,400 2,295	31,200 3,060	6,500 637.4
60	—	27	(M39)	16,000 1,569	28,800 2,824	38,400 3,766	8,000 784.5
65	—	32	M42	20,000 1,961	36,000 3,531	48,000 4,707	10,000 980.7
JIS B1180	JIS B1177	JIS B1176	Related standards	SS	SCr	SCr	C-B
			Material	S-C	SCM	SCM	C-R
			Strength classify (JIS B1051)	4·6 ~ 6·9	8·8 ~ 12·9	10·9 ~ 12·9	A-B

Note: 1. The size in () of width across flats is subject to other standards than JIS.
 2. Products for attached with () to the bolt and screw dia, should not be used if possible.

torque unit and conversion table

	Metric	SI unit	Imperial
Torque unit	kgf·cm kgf·m gf·cm	N·m N·cm	lbf·in lbf·ft OZf·in
Conversion in unit	1 kgf·m = 100 kgf·cm 1 kgf·cm = 1000 gf·cm 1 kgf·m = 10 kgf·mm	1 N·m = 100 N·cm	1 lbf·ft = 12 lbf·in 1 lbf·in = 16 OZf·in
Conversion between unit	1 kgf·cm = 0.098065 N·m 1 kgf·cm = 0.8679627 lbf·in 1 kgf·cm = 0.072330 lbf·ft	1 N·m = 10.1972 kgf·cm 1 N·m = 8.850 lbf·in 1 N·m = 0.737562 lbf·ft	1 lbf·in = 1.15 kgf·cm 1 lbf·in = 0.112985 N·m 1 lbf·ft = 13.825 kgf·cm 1 lbf·ft = 0.001356 N·m
Force unit	1 kgf = 9.807 N 1 kgf = 2.205 lbf	1 N = 0.101 972 kgf 1 N = 0.224809 lbf	1 lbf = 0.453592 kgf 1 lbf = 4.448 N (1 lbf = 16 OZf)
Length	1 cm = 0.393701 in	1 m = 3.281 ft	1 in = 2.54cm 1 ft = 0.305m (1 ft = 12 in)



<https://www.bestool-kanon.co.jp>

Improvement specifications subject to change without notice.

Distributed by:

Produced by :

NAKAMURA MFG. CO., LTD.

4-4, Ohi 4-Chome, Shinagawa-ku, Tokyo 140-0014, Japan

2022-7-●000