

Alignment stage for solder joint strength test SJS-100N-L/S

- Stage for fixing a PCB for solder joint strength test
- The stage angle switchable to 45 or 90 degrees

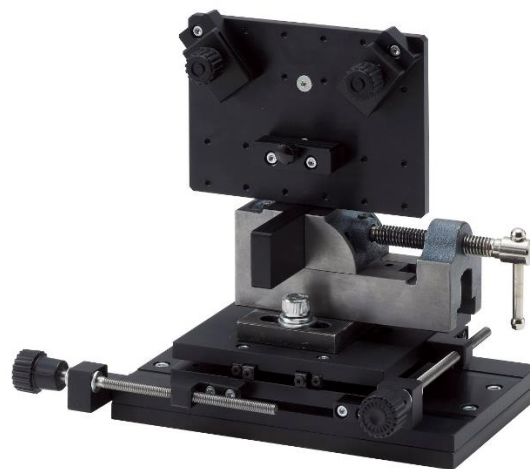



SJS-100N-L

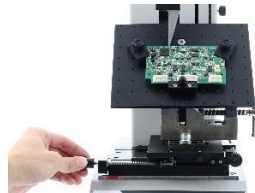

SJS-100N-S

How to Install the Test Sample (and SJS-1000N-L and SJ-QFP-01)

Fix sample to SJS-1000N-L.	Adjust position of hook tip with XY stage.	Hook the soldered part to start testing.
		

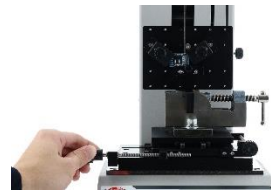
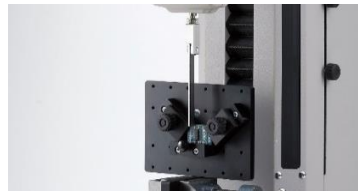

How to Install Test Sample (SJS-1000N-S and SJ-TIP-03)

Fix sample to SJS-1000N-S.	Adjust position of jig tip with XY stage.	Push the soldered part with jig to start testing.
		

Specifications		
Use	For mounting large sample	For mounting small sample
Model	SJS-100N-L	SJS-100N-S
Capacity	100N	
Dimension	Refer to the Dimension	
Weight *1	Approx. 3.2kg	Approx. 2.8kg
Moving distance of XY stage	+/-30mm	

*1 Weight of the attachment is also applied as a load on the force gauge. Consider it when selecting the capacity of a force gauge.

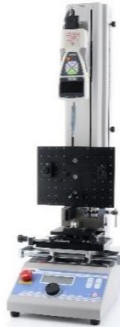
* Two clampers and two knobs are included.

Examples of Product Configuration SJ-QFP-01	
<p>Example 1 Code: 1S2008A IEC 62137-1-1:2007 Surface mounting technology - Environmental and endurance test methods for surface mount solder joint - Part 1-1: Pull strength test (Corresponding part only) (Japanese Standards: JIS C 62137-1-1: 2010) (Corresponding part only) (For large sample)</p> <p>Digital force gauge: ZTS-100N Motorized test stand: EMX-500N-L Optional attachment: SJ-QFP-01 Optional attachment: SJS-100N-L Optional attachment: XST-500N Optional cable: CB-528 Optional software: Force Recorder Standard</p>	 <p>SJ-QFP-01 Example1 Image</p>
Examples of Product Configuration SJ-TIP-02	
<p>Example 1 Code: 1S2009A JIS Z 3198-7: 2003 Test method for lead-free solders-Part 7: Method for shear strength of solder joints on chip components (Corresponding part only)</p> <p>Digital force gauge: ZTS-100N Motorized test stand: MX2-500N-L-V90 Optional attachment: SJ-TIP-02 Optional attachment: SJS-100N-L Optional attachment: XST-500N Optional cable: CB-528</p>	 <p>SJ-TIP-02 Example 1 Image</p>
Examples of Product Configuration SJ-TIP-03	
<p>Example 1 Code: 1S2010A IEC 62137-1-2:2007 Surface mounting technology - Environmental and endurance test methods for surface mount solder joint - Part 1-2: Shear strength test (Corresponding part only) (Japanese Standards: JIS C 62137-1-2: 2010) (Corresponding part only) (For small sample and tip diameter is 2mm or less)</p> <p>Digital force gauge: ZTS-100N Motorized test stand: EMX-500N Optional attachment: SJ-TIP-03 Optional attachment: SJS-100N-S Optional cable: CB-528 Optional software: Force Recorder Standard</p>	 <p>SJ-TIP-03 Example 1 Image</p>

* Refer to the specification of each product for the detail.

* Depending on the sample characteristics, product configuration, and measurement requirements vary, contact our authorized distributor or us for more information

* The maximum load value of the force gauge varies depending on the measuring sample requirements.

[PCB fixing stage, Sample Clamper and Knob] The parts below are also available for replacement.

Model	Included Parts	Images	
SJ-BB-L	PCB fixing stage (L)		
SJ-BB-S	PCB fixing stage (S)		
SCK-PRT *	Sample Clamper and Knob	 SCK-PRT	 Installation image

* This set of parts is sold in two pairs per order, not sold individually.

For enlarging the detailed work	
Magnifying glass enlarges the magnification to 2x or 4x and the neck angle can be adjusted freely, which improves the work efficiency.	
 Image	 Goose Neck Magnifier Magnet type 1720PM

Related Standards of Electronic Component	
Peeling test of embossed carrier tape which complies with corresponding part of IEC 60286-3 (2013) and JIS C0806-3 (2014)	Breaking strength test of cover tape which is a requirement of JIS C 0806-3 (2014)
Example Specialized tester: IPTS-5N	Example (*) Code: 1G2005A Digital force gauge: ZTS-200N Motorized test stand: MX2-500N-L Optional attachment: GC-60x2 Optional cable: CB-528

Related Products		
<p>QFP lead hook SJ-QFP-01</p> <p>For 45-degree pull strength test of solder joints complying with the corresponding part of IEC and JIS standards</p> 	<p>Chip shear jig SJ-TIP-01</p> <p>For 90-degree shear strength test of solder joints complying with the corresponding part of JIS standard Tip diameter: 0.25mm</p> 	<p>Chip shear jig SJ-TIP-02</p> <p>For 90-degree shear strength test of solder joints complying with the corresponding part of JIS standard Tip diameter: 0.5mm</p> 
<p>Chip shear jig SJ-TIP-03</p> <p>For 90-degree shear strength test of solder joints complying with the corresponding part of IEC and JIS standards Tip diameter: 2mm</p> 	<p>Chip shear jig SJ-TIP-04</p> <p>For 90-degree shear strength test of solder joints complying with the corresponding part of IEC and JIS standards Tip diameter: 4mm</p> 	<p>X-Axis slide table XST-500N</p> <p>Designed to move and adjust the stage in the X-axis direction easily</p> 
<p>Chip peel Fixture GT-10/20</p> <p>Ideal for shear test of electric components (Capacity: 500N)</p> 	<p>Small Grip SC-3/8</p> <p>Ideal for measurement of thin samples and narrow space such as electronic component</p> 	<p>Pantograph Grip PGC-0505</p> <p>Ideal for measurement in narrow spaces due to the thin chuck part</p> 
<p>Peeling Tester IPTS-5N</p> <p>Specialized for easy and precise peel test of embossed carrier tape</p> 		

[Dimensions]

SJS-100N-L

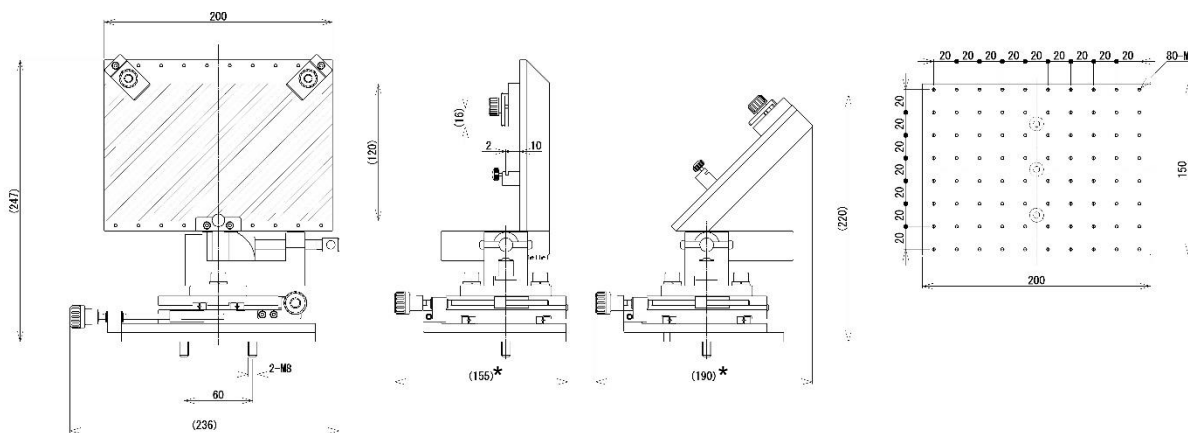

* The depth depends on the grip position of board and Y-axis position of the stage. Contact us for further details.

SJS-100N-S

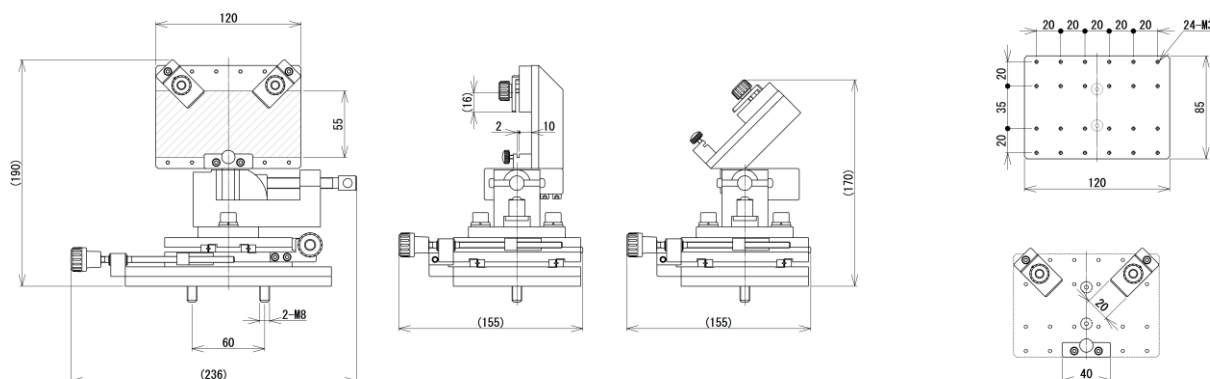

Unit : mm

[Cautions]

- The contents may be changed without prior notice.
- A force gauge (sold separately) is required to use this product.
- This product is designed for force testing only. Do not use it for any other purposes.
- Some samples may not be suitable to measure.
- Do not copy and use this content without authority.

SHRADDHA IMPEX
 Authorized Distributor

Email: shraddhaimpex@gmail.com / sales@shraddhaimpex.net
 Web: www.shraddhaimpex.net
 Contact: +91 9819530352 / +91 8591279918