

Testing Kit for 45-degree peel test

P45-50N

Peel test for packaging film recommended for food and medical industries
 Designed to easy test sample setting at 45-degree
 Easy sample fastening with adjustable lever, clear chuck and holding plate





Sample chuck



Table



Testing Image







How to Install test sample		
<p>Peel off a small part of the sample lid and place the sample on the table</p>	<p>Clump the sample lid with the sample chuck</p>	<p>Place the sample chuck cord around the roller of the table and hook the end to the chuck cord to the Force gauge</p>
		

Specifications	
Model	P45-50N
Maximum Capacity	50N
Maximum sample size	Height:10-100mm Diameter:20-140mm
Dimensions	as diagram in page 4/4
Weight *1	Sample grip: approx.10g Table: approx.1500g
Mountable Test Stand *2	MX-500N-L, MX-1000, MX2-500N-L, MX2-1000N, HV-500 II -L, HV-1000N

- * Possible testing area varies depending on the size of the packages
- * This testing kit does not cater for full opening test. Custom- made order is available for full opening test. Please refer to page 3/4.
- * Original testing kit can be customized to your measuring requirement
- * Standard small hook (A-1/S-1/SR-1) is required for this test.
- *1 When selecting the force capacity, weight of the chuck must be included to the force gauge load.
- *2 Please contact us for other testing stands installment

Examples of Product Configuration P45-50N	
<p>Example1 Code : 1P2010A</p> <p>- simple 45-degree peel test up to 50N</p> <p>Digital force gauge : DST-200N Motorized Test Stand : MX-500N-L Optional attachment : P45-50N *2</p>	 <p>Example2 Image</p>
<p>Example2 Code : 1P2010B</p> <p>- Functional 45-degree peel test up to 50N</p> <p>Digital force gauge : ZTS-100N Motorized Test Stand : MX2-500N-L *1 Optional Motorized Test Stand : -V600 Optional Attachment : P45-50N *2 Optional Cable : CB-528</p>	

- * Please refer to the specification of each product for details.
- * Product configuration varies depending on the shape and characteristic of the sample and measurement conditions
- * The recommended capacity of the force gauge varies depending on the expected force to be loaded.
- * Custom-made order is available for **JIS S0021-2:2018** 「Packaging-Accessible design-Ease of opening」 and **ISO17480:2015** 「Packaging -- Accessible design -- Ease of opening」 (**Full Opening test**) Please refer to page 3/4.
- *1 MX2 series test stands are recommended with appropriate moving speed for 45-degree angle peel test.
- *2 With the possibilities of liquid splashing, while testing, use of the Tray PTW-10IN (not included in the kit) is recommended.

Related Accessories and Jigs (available separately)		
<p>Tray PTW-10IN</p>	<p>Beverage Can Tab pulling force testing kit PTD-100N</p>	<p>Food Can Tab pulling force test kit PTF-100N</p>
<p>Tray is to be fixed under the testing kit for splash protection when measuring liquid product packaging</p>	<p>For measuring pulling force of the stay-on-tabs on the beverage cans</p>	<p>For measuring easy open pull tabs: pulling and opening</p>
		
<p>Screw Cap Torque tester DTXS/DTXA Series</p>	<p>Food Texture analyzer FRTS-5N/50N/100N</p>	<p>Food Hardness Testing Unit FCA-DSV-50N</p>
<p>For bottle screw caps torque force measurements: Opening and Closures</p>	<p>For evaluation of the textural property variations with simple touch screen operation.</p>	<p>For measurement of food hardness by simple operation.</p>
		

[Custom-made Kit (made to order) for full opening test]

For ISO17480:2015 「Packaging -- Accessible design -- Ease of opening」 and (Corresponding Japanese standard: JIS S0021-2:2018) (corresponding part only) *Please contact us for the custom-made Kit

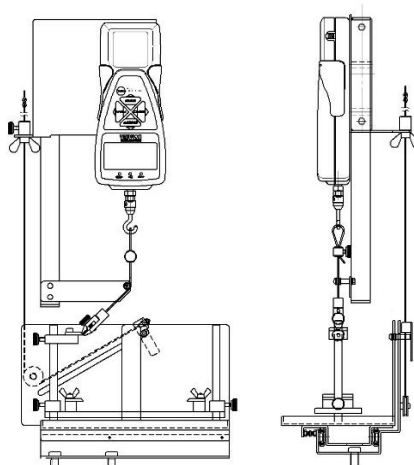

[Dimensions]

Table

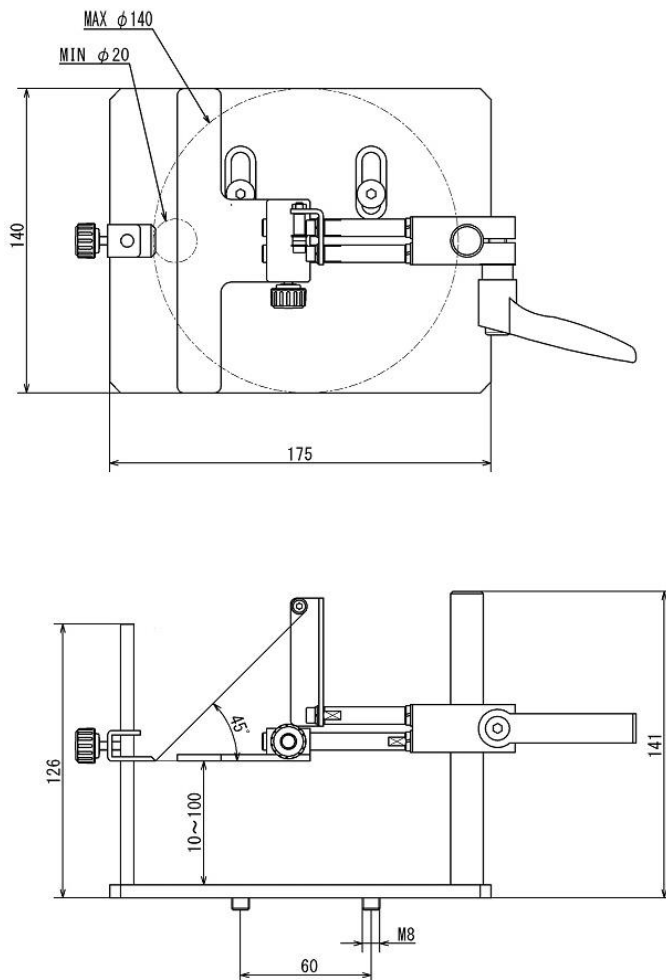

Sample chuck

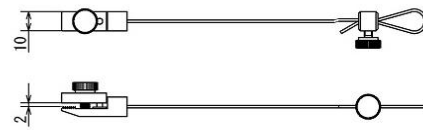

Unit: mm

[Cautions]

- Information in this document is subject to change without prior notice.
- This document is product descriptions and handling precautions, and do not guarantee various characteristics or safety.
- This product is designed for force measurement purpose only.
- Do not copy and use this content without authorization.
- A force gauge (sold separately) is required to use this product.
- Some samples may not be suitable to measure with this product.

SHRADDHA IMPEX
Authorized Distributor

Email: shraddhaimpex@gmail.com / sales@shraddhaimpex.net

Web: www.shraddhaimpex.net

Contact: +91 9819530352 / +91 8591279918