

XY Table

XY-500N series

- It allows minor adjustment of sample position, which is ideal for tension/compression testing of small samples such as PCB (only for XY-500N-M8/BB)
- Low table secures stroke of vertical test stand



XY-500N-BB



XY-500N-M8





XY-500N-EZ

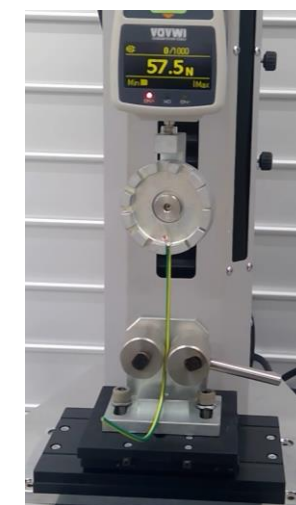

XY-500N-M8 Testing Image

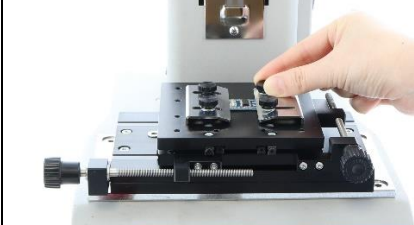

XY-500N-EZ Test Image





How to use XY-500N-BB		
Fix it to the test stand	Fix the sample	Rotate the knob to adjust the position in X and Y axis direction
		







Specification			
Model	XY-500N-BB	XY-500N-M8	XY-500N-EZ
Testing type	Tension and compression		Tension
Usage	-Fix the sample directly on the table	-Mount the vise grip on the table -Mount the GF-1 and optional attachment on the table	-Adjust the pulling position easily by the free movable table
Features	-Fine and simple position adjustment -Fix the sample directly on the table by the supplied plate	-Fine and simple position adjustment -Mount attachments (*1)	-For tension test only - Automatically adjust the pulling position to the center by the free movable table -Mount attachments (*1)
Compression capacity	1000N		-
Tension capacity	500N		500N
X-axis stroke	±30mm		
Y-axis stroke	±30mm		
Feeding method	Feed screw		Free
Travel	0.8 mm / every single turn of the knob		-
Hole size	M4	M8	M8
Dimensions	See [Dimension]		
Weight	Approx. 1.5kg	Approx. 1.5kg	Approx. 1.4kg

* The available stroke of test stands becomes shorter after installing the table. Consider it when selecting the stroke of a test stand.

* The resistance force (less than 1N) occurred when table is moving may affect the test result of low-capacity testing.

*1 Mount vise grip & attachments or GF-1/-2 & attachments to perform test.

Mountable Test Stand			
Motorized Test Stand		Manual Test Stand	
MX-500N MX-1000N	MX2-500N MX2-1000N MX2-2500N MX2-5000N EMX series	SVL-1000N SVH-1000N	HV-500N II HV-1000N HV-3000N
			
MX-500N	EMX-1000N	SVL-1000N	HV-500N II

Related Products		
Vise Grip GT-30/2000N	Self-centering Vise Grip GTW-50R/50L	Chuck for Clamping Cap CCJ series
		
It is used to grip and fix samples, being mounted on a vertical test stand. It is available in capacity from 250N up to 2000N.	It is self-centering vise. It is available in capacity from 500N to 1000N.	It is designed for gripping round-shaped samples tightly by the 4 pins.
Alignment stage for solder joints strength test SJS-100N-L/S	X-Axis slide table XST-500N	Universal Joint UJ6-1000N/UJ10-5000N
		
It is designed for fixing a PCB to test pull and shear strength of solder joints to adjust in the XY-axis direction finely and change the angle to 45 degrees or 90 degrees.	It is designed to move and adjust in the X-axis direction easily.	It is an optional attachment to prevent unbalanced load.

[Dimension]

XY-500N-BB

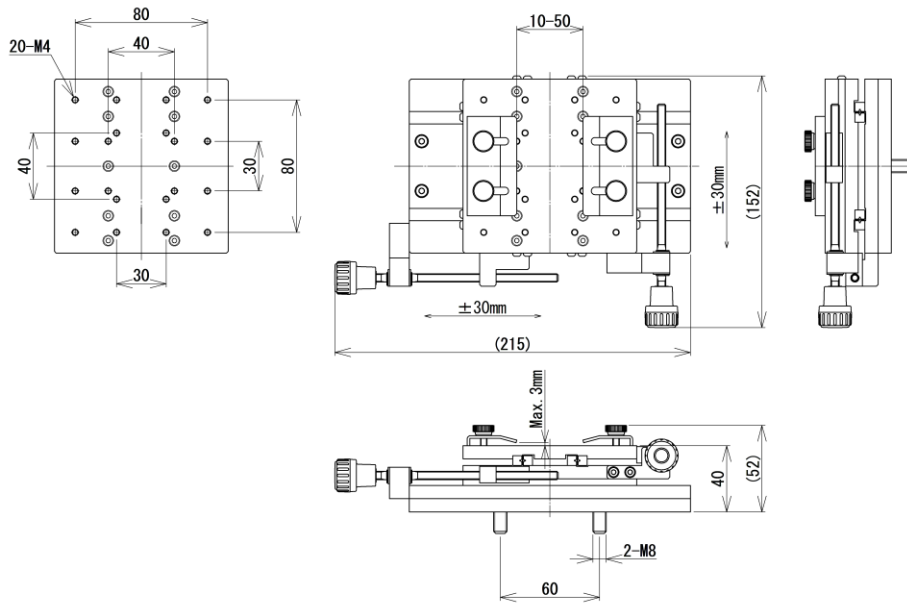

XY-500N-M8

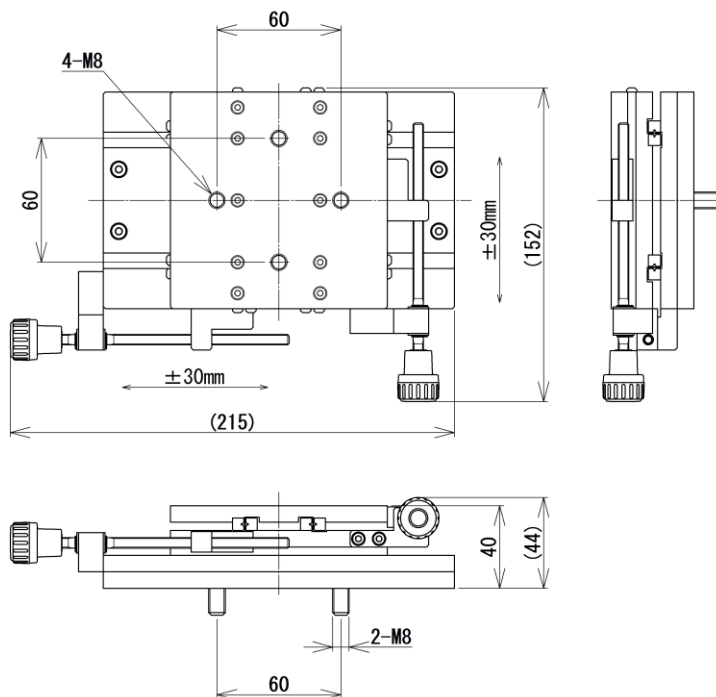

XY-500N-EZ

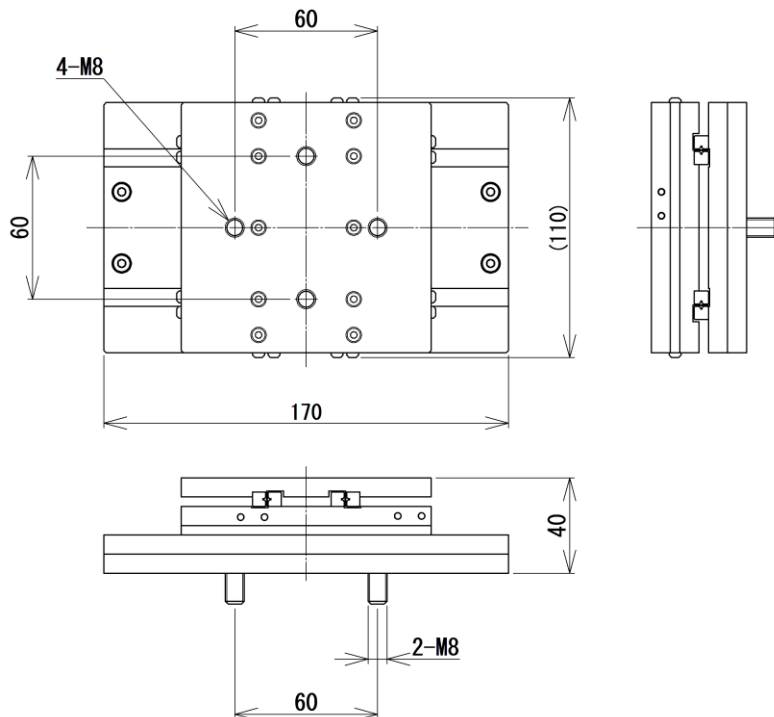

Unit: mm

[Cautions]

- Information in this document is subject to change without prior notice.
- This document is product descriptions and handling precautions, and do not guarantee various characteristics or safety.
- This product is designed for force measurement purpose only.
- Do not copy and use this content without authorization.
- A force gauge (sold separately) is required to use this product.
- Some samples may not be suitable to measure with this product.

SHRADDHA IMPEX
Authorized Distributor

Email: shraddhaimpex@gmail.com / sales@shraddhaimpex.net

Web: www.shraddhaimpex.net

Contact: +91 9819530352 / +91 8591279918