

X-axis Slide Table XST-500N



- This table enables you to align test sample very easily, improving test efficiency.
- Simply move the table as required to set the sample at the appropriate position.





XST-500N



Mounting image

Application	
Align test sample very easily.	Move the table as required.
 <p>This table's smooth move and easy fixing by knobs improve test efficiency, which is useful for example when you test many electric components on a circuit board in a row.</p>	 <p>It handles even the test samples which is unable to be centered.</p>





Usage	
Fix Grip Mounting Adapter GF-1/GF-2 (*) supplied with test stand to XST-500N and mount optional attachment on it.	Fix vise grip to XST-500N directly.
	







* Grip Mounting Adapter GF-1/GF-2 is not included in manual test stands SVL-1000N/SVH-1000N.

Specification	
Model	XST-500N
Capacity	500N
Movable displacement	70mm
Dimensions	See [Dimensions].
Weight	Approx. 1.9kg

* Fix the knobs firmly when applying force.

* Note that the stage may move horizontally if the knobs are not fixed enough or high unbalanced load is applied.

Mountable to the following test stands			
Motorized test stands		Manual test stands	
MX-500N MX-1000N	MX2-500N MX2-1000N MX2-2500N MX2-5000N EMX series	SVL-1000N SVH-1000N	HV-500N2 HV-1000N HV-3000N
			
MX-500N	EMX-1000N	SVL-1000N	HV-500N2

Related Products		
Alignment stage for solder joints strength test SJS-100N-L/S	XY-table XY-500N series	Cap clamping jig CCJ series
Designed for fixing PCB in solder joint strength test and shear test. Fine tuning in X and Y axis. Angle changeable (45 or 90 degree).	Finely adjust sample's position in X and Y axis. Suitable for tiny sample such as components on PCB.	Designed for gripping round-shaped samples. The 4 pins grip sample firmly.
		
Vice Grip GT-30/2000N	Self-centering Vice GTW-50R/50L	GTW-2500N
Available in capacity from 250N up to 2000N.	Self-centering vise. Available in capacity from 500N to 1000N.	Self-centering vise, made of stainless in capacity up to 2500N.
		

* Refer to specifications of the individual product for details.

[Dimensions]

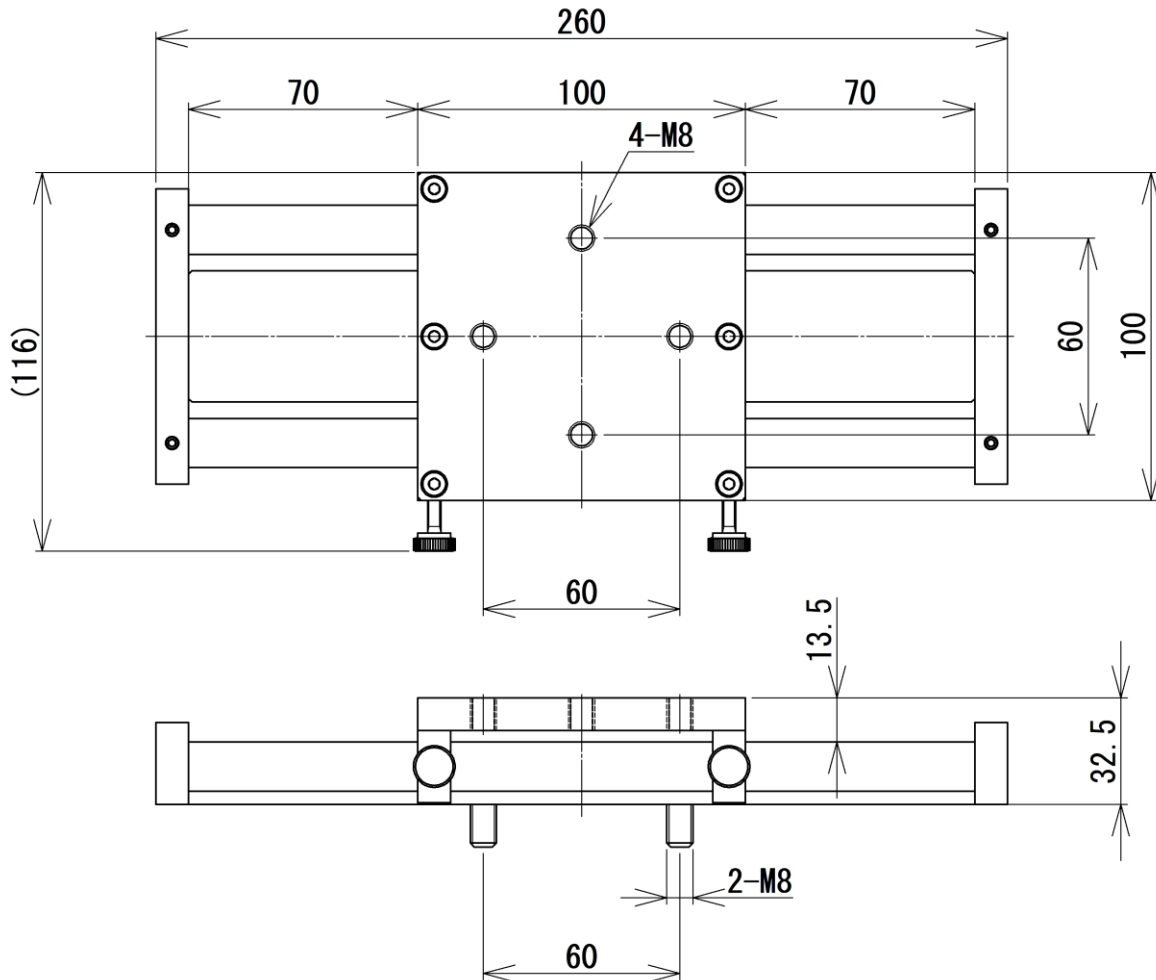

Unit: mm

[Cautions]

- Information in this document is subject to change without prior notice.
- This document is product descriptions and handling precautions, and do not guarantee various characteristics or safety.
- This product is designed for force measurement purpose only.
- Do not copy and use this content without authorization.

SHRADDHA IMPEX
Authorized Distributor

Email: shraddhaimpex@gmail.com / sales@shraddhaimpex.net

Web: www.shraddhaimpex.net

Contact: +91 9819530352 / +91 8591279918