

Simple Manual Test Stand SVL-1000N/SVH-1000N

Both tensile and compressive force can be measured
Uniformity of measurement direction brings high repeatability
Simple operation by lever or handle

For operational efficiency
Lever Operation
SVL-1000N





For movement control
Handle Operation
SVH-1000N



* Force gauge is not included

Feature 1	Feature 2	Feature 3	Feature 4
Up to 1000N measurement	Stroke control by mechanical stopper	Various options are available	Easy carry with light weight
Both tensile and compressive force can be measured with this manual test stand with force gauge.	Stroke is adjustable by mechanical stopper function.	Various options are available such as length meter and long stroke for wide measurement needs.	Light weight body enable to measure force at diverse places.



Measurement example		
Simple spring test	Sewed strength of button	Pull off strength of connector
		

* Force gauge and grips are not included.

Specifications		
Model	SVL-1000N	SVH-1000N
Capacity	1000N	
Force direction	Tension and compression	
Travel method	Lever	Handle
Travel per 1 turn	60mm per 170 degrees	3 mm
Max. Sample Height *1	Approx. 225mm	
Stroke	60 mm	
Function	Mechanical stopper	
Weight	Approx. 7.3 kg	Approx. 7.7 kg
Dimension	See [Dimensions]	
Fixable force gauge *2	Digital force gauge: DST, DSV, ZTS, ZTA series Mechanical force gauge: FB, PS, PSM series	

*1 The Max. Sample Height refers to the distance between the test stand table and the tip of force gauge (1000N or less of ZT series) measuring shaft when the head is at the top.

*2 Some high capacity model force gauges (with M10 thread) and load cells cannot be mounted to the test stand. Please check the dimensions before purchase.

Available Options		
Extended column Order code: -EXT Ex) SVH-1000N-EXT	Length meter Order code: -S Ex) SVH-1000N-S	Grip mounting adapter GF-1
		
For bigger sample measurement The column and max. sample height extend 200mm *The stroke does not extend.	Digital display of displacement Resolution: 0.01mm	Mount attachments to test stand base

Recommended force gauge		
Simple measurement	Simple measurement	With more functions
 <p>Mechanical force gauge FB series</p>	 <p>Digital force gauge DST/DSV series</p>	 <p>Digital force gauge ZTS/ZTA series</p>

[Dimensions]

SVL-1000N

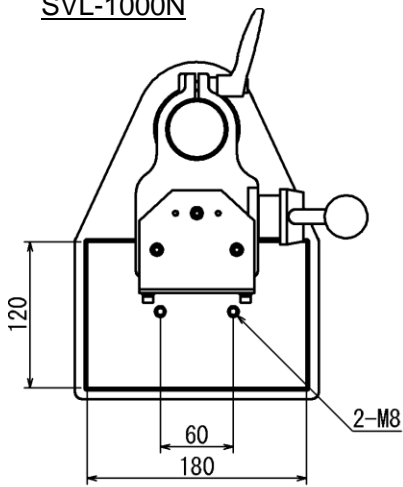

	Standard	Extended column (-EXT)
H	410	610
R	265	465

Unit: mm

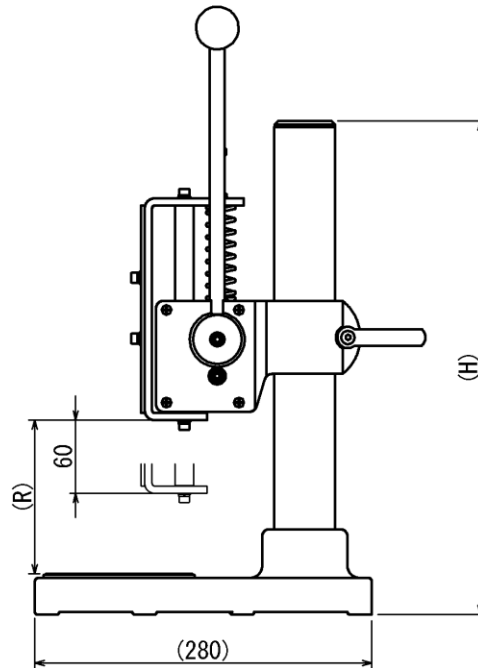
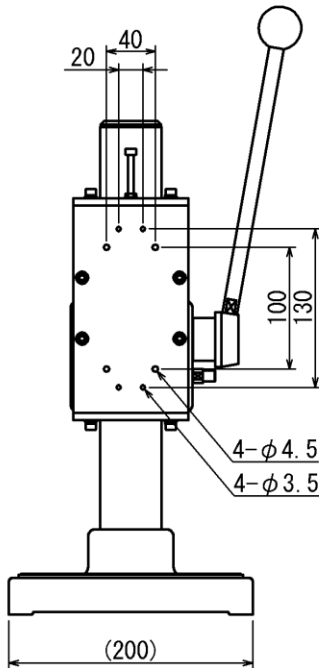

SVH-1000N

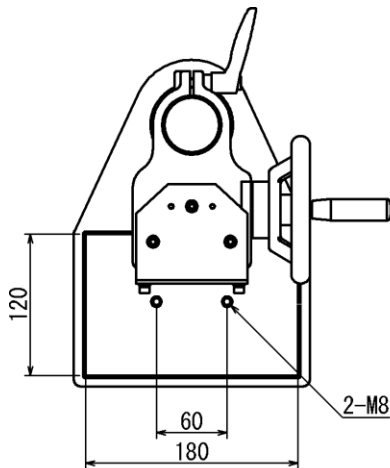

	Standard	Extended column (-EXT)
H	410	610
R	265	465

Unit: mm

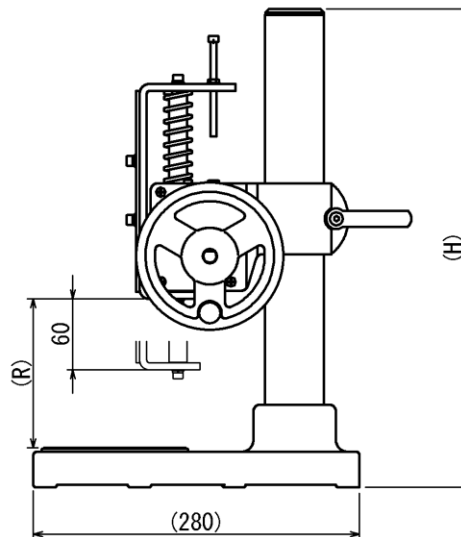
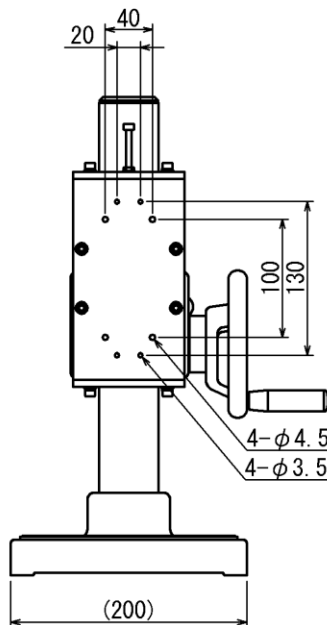

[Cautions]

- Information in this document is subject to change without prior notice.
- This document is product descriptions and handling precautions, and do not guarantee various characteristics or safety.
- This product is designed for force measurement purpose only.
- Do not copy and use this content without authorization.
- A force gauge (sold separately) is required to use this product.
- Do not use this product in the environments including fierce temperature changes, high temperature, high humidity, near water, dusty place.

SHRADDHA IMPEX
Authorized Distributor

Email: shraddhaimpex@gmail.com / sales@shraddhaimpex.net
Web: www.shraddhaimpex.net
Contact: +919819530352/ +918591279918