

GENERAL CATALOG



TORQUE WRENCH

AND ANALYZER

<http://www.bestool-kanon.co.jp>



NAKAMURA MFG.CO.,LTD.
TSURU FACTORY



ISO 9001
JQA-2434



ISO 14001
JQA-EM1367

BESTOOL-KANON

Exploring the frontiers of higher accuracy and reliability.

Every single fastener fulfills an important function maintaining the life of every product. In the transportation or chemical industries, if a fastener loosens from improper tightening, it might cause a serious disaster costing human life. We focus our techniques and wisdom, accumulated over many years, on preventing such occurrences.

Tightening only by hand will cause unexpected disaster. For example,

Traffic accidents

Improper wheel nut tightening resulting in wheels coming off.

Construction accidents

Improper tightening of structural joints resulting in collapsing scaffolding or buildings.

Explosions

Improperly tightened underground gas line joints resulting in leakage and explosion.

Chemical accidents

In chemical plants, improperly tightened joints can release toxic substances.

Torque tools play an important role in preventing such incidents.

Torque tools tighten joints uniformly with adequate force.

In particular they serve:

1. To prevent under-or-over-tightening.
2. To tighten multiple bolts uniformly.
3. To adequately generate the clamping force required for bolted joints.

BESTOOL-KANON

NOTE: Can be calibrated to : Inch pounds, Foot pounds, Newton meters.

PAGE 3
DTC-EXL
DATA PRINT-OUT DIGITAL
TORQUE WRENCHES

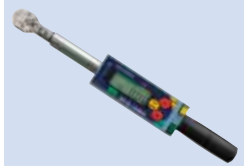

PAGE 4
DTDK-EXL
DIGITAL TORQUE DRIVER
WITH CONNECTED DISPLAY



PAGE 4
DTC-N5EXL
DIGITAL TORQUE WRENCH
WITH CONNECTED DISPLAY



PAGE 5
SPK
PRE-SET
TORQUE WRENCHES

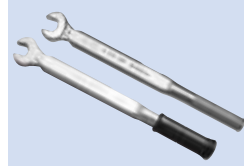

PAGE 6
RSPK
PRE-SET, RING
TORQUE WRENCHES

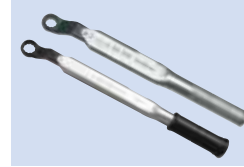

PAGE 7
QLK
ADJUSTABLE, RATCHET
TORQUE WRENCHES



PAGE 8
GLK/BLK
ADJUSTABLE, RATCHET TORQUE
WRENCHES WITH PLASTIC GRIP

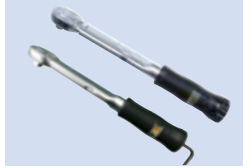

PAGE 9
QSPK
QSPKH, QSPK-A

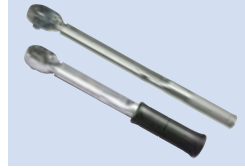

PAGE 10
SPCK/SPCKH
PRE-SET, REPLACEABLE HWAD
TORQUE WRENCHES

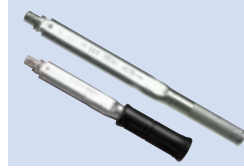

PAGE 11
LCK/GCK
ADJUSTABLE, REPLACEABLE
HEAD TORQUE WRENCHES

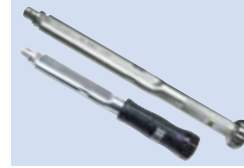

PAGE 12
HEADS
OPTIONAL REPLACEABLE
HEADS

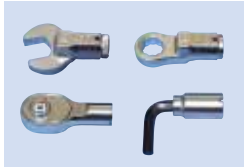

PAGE 13
**QLK-LR/
HYK**

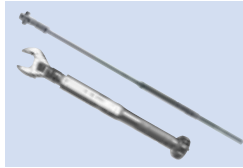

PAGE 14
FK
INDICATOR PLATE
TORQUE WRENCHES

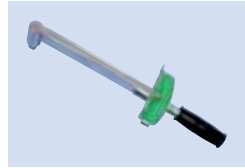

PAGE 15
**MLK
MLK-E**

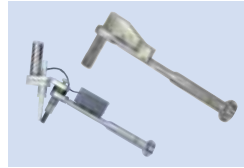

PAGE 16
TOK-G
DIAL INDICATOR
TORQUE WRENCHES

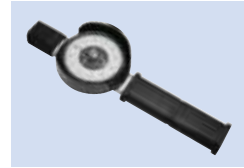

PAGE 17
LTDK
CLUTCH RELEASE TORQUE
SCREW DRIVERS



PAGE 18
STDK
PRE-SET TORQUE DRIVERS



PAGE 19
DPSK
DIAL GAUGE
TORQUE DRIVERS

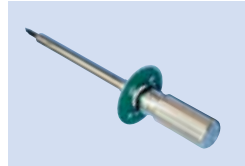

PAGE 20
SGK
TORQUE GAUGES



PAGE 21
KDTA-SV
DIGITAL TORQUE ANALYZERS



PAGE 22
KDTA-SVH
LARGE DIGITAL TORQUE
ANALYZERS



PAGE 22
TPK-3
STANDARD PRINTER



PAGE 23
KDTA-SVII
DIGITAL TORQUE ANALYZERS



PAGE 23
KDTA-SVEX
AUTOMATIC
DIGITAL TORQUE ANALYZERS



PAGE 24
KDTA-DH
DIGITAL TORQUE ANALYZERS
FOR TORQUE DRIVERS



PAGE 24
KDTA-D
DIGITAL TORQUE ANALYZERS
FOR ELECTRIC DRIVERS



PAGE 25
CTK-XL CAP
TESTER
DIGITAL CAP
TORQUE ANALYZERS



PAGE 26
TK
TENSION GAUGES



PAGE 27
TCSK-99MA
MULTI-FUNCTION TORQUE
TASK MANAGER /ANALYZER



PAGE 28
SWPM Series
TORQUE TOOLS FOR TCSK

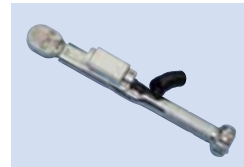

DTC-EXL DATA PRINT-OUT DIGITAL TORQUE WRENCHES

Newly designed, features a multi-function digital read-out.



FEATURES

- Accuracy : $\pm 1\%$ of indicated value + 1 increment, over the full range
- Display : torque reading 4-digit LCD display
- Measurement modes : ①Peak hold ②Peak to peak-hold ③Run
- Direction of measurement : Automatic CW/CCW changeover, provided with CW/CCW status display
- Power supply : two rechargeable "AA" 1.2V batteries and a 100-240V battery charger
- Battery life : Approximately 20 hours with fully charged batteries (continuous operation)
- Power off : Auto power-off, approximately 3 minutes 40 seconds
- Tolerance setting : Automatic judgement capability per the Min/Max settings
- Data memory : 100 pieces of data
- Output : Printer output (exclusively to a TPK-3), analog output << 0 to 1.024 (mid point) to 2.048 V >>

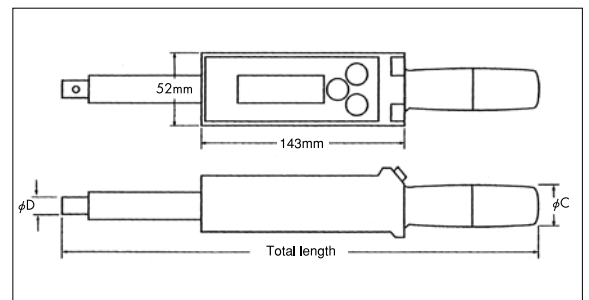

| Model | Range (CW/CCW) | Increment | Total length (mm) | φ D (mm) | φ C (mm) | Weight (kg) | Accessory |
|--------------|-----------------|-------------|-------------------|----------|----------|-------------|------------|
| DTC-100EXL | 10~100 kgf.cm | 0.1 kgf.cm | 300 | 10 | 26 | 0.7 | 120 QCK |
| DTC-500EXL | 50~500 kgf.cm | 0.5 kgf.cm | 324 | 12 | 26 | 0.7 | 450 QCK |
| DTC-1000EXL | 100~1000 kgf.cm | 1 kgf.cm | 365 | 15 | 32 | 0.8 | 900 QCK |
| DTC-2000EXL | 200~2000 kgf.cm | 1 kgf.cm | 380 | 18 | 32 | 0.9 | 1800 QCK |
| DTC-3000EXL | 3~30 kgf.m | 0.02 kgf.m | 535 | 22 | 32 | 1.5 | 2800 QCK-A |
| DTC-5000EXL | 5~50 kgf.m | 0.05 kgf.m | 1,063 | 30 | 34 | 3.9 | 7000 QCK |
| DTC-10000EXL | 10~100 kgf.m | 0.1 kgf.m | 1,417 | 34 | 34 | 7.3 | 10000 QCK |
| DTC-N10EXL | 1~10 N.m | 0.01 N.m | 300 | 10 | 26 | 0.7 | 120 QCK |
| DTC-N50EXL | 5~50 N.m | 0.05 N.m | 324 | 12 | 26 | 0.7 | 450 QCK |
| DTC-N100EXL | 10~100 N.m | 0.1 N.m | 365 | 15 | 32 | 0.8 | 900 QCK |
| DTC-N200EXL | 20~200 N.m | 0.1 N.m | 380 | 18 | 32 | 0.9 | 1800 QCK |
| DTC-N300EXL | 30~300 N.m | 0.2 N.m | 535 | 22 | 32 | 1.5 | 2800 QCK-A |
| DTC-N500EXL | 50~500 N.m | 0.5 N.m | 1,063 | 30 | 34 | 3.9 | 7000 QCK |
| DTC-N1000EXL | 100~1000 N.m | 1 N.m | 1,417 | 34 | 34 | 7.3 | 10000 QCK |
| DTC-P180EXL | 8~80 lbf.in | 0.01 lbf.in | 300 | 10 | 26 | 0.7 | 120 QCK |
| DTC-P1400EXL | 40~400 lbf.in | 0.1 lbf.in | 324 | 12 | 26 | 0.7 | 450 QCK |
| DTC-P1800EXL | 80~800 lbf.in | 0.1 lbf.in | 365 | 15 | 32 | 0.8 | 900 QCK |
| DTC-PF100EXL | 10~100 lbf.ft | 0.1 lbf.ft | 380 | 18 | 32 | 0.9 | 1800 QCK |
| DTC-PF200EXL | 20~200 lbf.ft | 0.1 lbf.ft | 535 | 22 | 32 | 1.5 | 2800 QCK-A |
| DTC-PF400EXL | 40~400 lbf.ft | 0.2 lbf.ft | 1,063 | 30 | 34 | 3.9 | 7000 QCK |
| DTC-PF800EXL | 80~800 lbf.ft | 1 lbf.ft | 1,417 | 34 | 34 | 7.3 | 10000 QCK |

DTDK-EXL

DIGITAL TORQUE DRIVER WITH CONNECTED DISPLAY

The display is separate from the driver. Complete tightening control for small screws.

FEATURES

- Accuracy : $\pm 1\%$ of indicated value +1 increment, over the full range
- Display : torque reading 4-digit LCD display
- Measurement modes : ①Peak hold ②Peak to peak-hold ③Run
- Direction of measurement : Automatic CW/CCW changeover, provided with CW/CCW status display
- Power supply : two rechargeable "AA" 1.2V batteries and a 100-240V battery charger
- Battery life : Approximately 20 hours with fully charged batteries (continuous operation)
- Power off : Auto Power-off, approximately 3 minutes 40 seconds
- Tolerance setting : Automatic judgement capability per the Min/Max settings
- Data memory : 100 pieces of data
- Output : Printer output (exclusively to a TPK-3), analog output << 0 to 1.024 (mid point) to 2.048 V >>

| Model | Range (CW/CCW) | Increment | Weight (kg) | Included Accessory |
|--------------|----------------|-------------|-------------|------------------------------------|
| | | | | Standard bills Phillips SB type |
| DTDK-20EXL | 2~20 kgf.cm | 0.01 kgf.cm | 1 | No.0, No.1 |
| DTDK-50EXL | 5~50 kgf.cm | 0.05 kgf.cm | 1 | No.1, No.2 |
| DTDK-N2EXL | 20~200 cN.m | 0.1 cN.m | 1 | No.0, No.1 |
| DTDK-N5EXL | 50~500 cN.m | 0.5 cN.m | 1 | No.1, No.2 |
| DTDK-PI40EXL | 4~40 lbf.in | 0.01 lbf.in | 1 | No.1, No.2 |

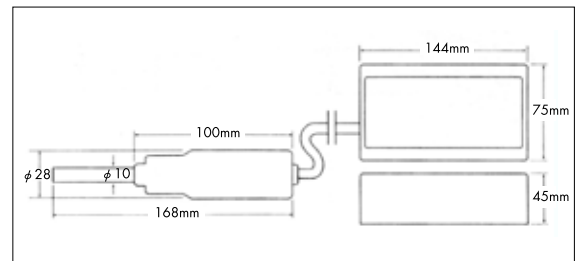

DTC-N5EXL

DIGITAL TORQUE WRENCH WITH CONNECTED DISPLAY

The display is separate from the wrench. The slender wrench body facilitates measuring lower torques.

FEATURES

- Accuracy : $\pm 1\%$ of indicated value +1 increment, over the full range
- Display : torque reading 4-digit LCD display
- Measurement modes : ①Peak hold ②Peak to peak-hold ③Run
- Direction of measurement : Automatic CW/CCW changeover, provided with CW/CCW status display
- Power supply : two rechargeable "AA" 1.2V batteries and a 100-240V battery charger
- Battery life : Approximately 20 hours with fully charged batteries (continuous operation)
- Power off : Auto Power-off, approximately 3 minutes 40 seconds
- Tolerance setting : Automatic judgement capability per the Min/Max settings
- Data memory : 100 pieces of data
- Output : Printer output (exclusively to a TPK-3), analog output << 0 to 1.024 (mid point) to 2.048 V >>

| Model | Range (CW/CCW) | Increment | Weight (kg) | Accessory |
|-------------|----------------|-------------|-------------|-----------|
| DTC-50EXL | 5~50 kgf.cm | 0.05 kgf.cm | 0.9 | 120QCK |
| DTC-N5EXL | 50~500 cN.m | 0.5 cN.m | 0.9 | 120QCK |
| DTC-PI40EXL | 4~40 lbf.in | 0.01 lbf.in | 0.9 | 120QCK |

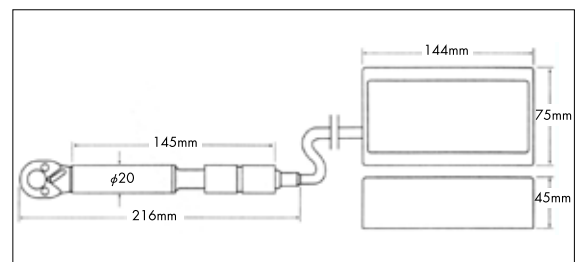

SPK PRE-SET TORQUE WRENCHES

Audible and tangible "CLICK" when the set torque is reached, assuring a securely tightened joint. This series is well-suited for production line use.

FEATURES

- A single function wrench, used for a single setting combination of fastener size and torque setting.
- Most suited for tightening multiple same-size fasteners at the same torque in a production line.
- Setting confirmation unnecessary.
- Can be used effectively in confined spaces.
- Tightening to set torque only in the direction of the arrow indicator, but can be used for general tightening in the other direction as well.
- Accuracy : $\pm 3\%$ of pre-set value



SPK (Metal Handle)



(N) 80~670 SPKH (with Rubber Grip)

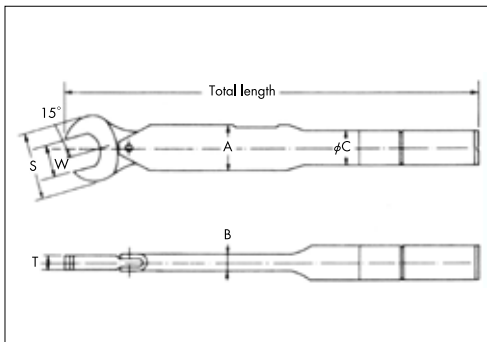

EXAMPLE OF ORDER

Model Size(W) Pre-set Value
 | | |
 N190SPK 10 × 14N·m

| Model (kgf·cm) | Range kgf·cm | Model (N·m) | Range N·m | Available sizes (W) mm | | | | | | Total length mm | Dimensions (mm) | | | | | Weight kg | | | | | |
|----------------|--------------|-------------|-----------|------------------------|----|----|----|----|-----|-----------------|-----------------|------|------|------|------|-----------|----|------|------|------|-----|
| | | | | | | | | | | | Head | | Body | | | | | | | | |
| | | | | | | | | | S | T | A | B | C | | | | | | | | |
| 30SPK | 5~30 | N30SPK | 0.5~3 | 5.5 | 6 | | | | 152 | 24 | 5 | 19.5 | 7.5 | 15 | 0.1 | | | | | | |
| 80SPK | 15~80 | N80SPK | 1.5~8 | 7 | 8 | 9 | 10 | | 175 | 24 | 5 | 19.5 | 7.5 | 15 | 0.11 | | | | | | |
| | | | | 8 | 9 | 10 | 11 | 12 | | | | | | | | 13 | | | | | |
| 190SPK | 35~190 | N190SPK | 3.5~19 | 10 | 11 | | | | 203 | 27 | 7 | 19.5 | 7.5 | 15 | 0.15 | | | | | | |
| | | | | 12 | 13 | 14 | | | 205 | 30 | | | | | | | | | | | |
| | | | | 17 | 19 | | | | 213 | 35 | | | | | | | | | | | |
| | | | | 10 | 11 | 12 | 13 | 14 | 248 | 35 | | | | | | | | | | | |
| 380SPK | 80~380 | N380SPK | 8~38 | 17 | 19 | | | | 252 | 39 | 8 | 26.6 | 8.2 | 20 | 0.29 | | | | | | |
| | | | | 21 | 22 | 23 | 24 | | 256 | 45 | | | | | | | | | | | |
| | | | | 26 | 27 | 29 | 30 | 32 | 264 | 52 | | | | | | 9 | | | | | |
| | | | | 14 | 17 | 19 | 21 | | 319 | 45 | | | | | | 10 | | | | | |
| 670SPK | 130~670 | N670SPK | 13~67 | 22 | 24 | 26 | | | 325 | 50 | 11 | 25.8 | 9.7 | 20 | 0.45 | | | | | | |
| | | | | 27 | 30 | 32 | | | 330 | 56 | | | | | 0.46 | | | | | | |
| | | | | 36 | 41 | | | | 342 | 65 | | | | | 0.47 | | | | | | |
| | | | | 17 | 19 | 22 | | | 390 | 52 | | | | | 0.49 | | | | | | |
| 1200SPK | 240~1,200 | N1200SPK | 24~120 | 24 | 26 | 27 | | | 397 | 57 | 12 | 32.8 | 11.3 | 25 | 0.75 | | | | | | |
| | | | | 29 | 30 | 32 | | | 403 | 62 | | | | | 0.77 | | | | | | |
| | | | | 36 | 41 | | | | 404 | 64 | | | | | 14 | 0.79 | | | | | |
| | | | | 19 | 22 | | | | 435 | 53 | | | | | 12 | 0.81 | | | | | |
| 1600SPK | 300~1,600 | N1600SPK | 30~160 | 24 | 26 | | | | 442 | 56 | 12 | 32.8 | 11.3 | 25 | 0.94 | | | | | | |
| | | | | 27 | 30 | 32 | 36 | | 449 | 64 | | | | | 14 | 0.97 | | | | | |
| | | | | 41 | | | | | 457 | 73 | | | | | 14 | 0.99 | | | | | |
| | | | | 19 | 22 | | | | 585 | 72 | | | | | 15 | 1.1 | | | | | |
| 2200SPK | 450~2,200 | N2200SPK | 45~220 | 24 | 27 | | | | 597 | 82 | 15 | 35.6 | 12.5 | 27.2 | 1.1 | | | | | | |
| | | | | 30 | 32 | 36 | | | | | | | | | 597 | 82 | 15 | 35.6 | 12.5 | 27.2 | 1.2 |
| | | | | 41 | | | | | | | | | | | | | | | | | 597 |
| | | | | 22 | 24 | | | | | | | | | | 650 | 67 | 16 | 1.5 | | | |
| 3100SPK | 650~3,100 | N3100SPK | 65~310 | 27 | 30 | 32 | | | 654 | 72 | 16 | 38.0 | 16 | 30 | 1.3 | | | | | | |
| | | | | 36 | 41 | | | | 662 | 82 | | | | | 18 | 1.32 | | | | | |
| | | | | 24 | 27 | | | | 833 | 74 | | | | | 18 | 1.4 | | | | | |
| | | | | 30 | 32 | | | | 838 | 78 | | | | | 18 | 1.46 | | | | | |
| 4200SPK | 900~4,200 | N4200SPK | 90~420 | 36 | | | | | 843 | 82 | 18 | 43.3 | 17.8 | 34 | 1.47 | | | | | | |
| | | | | 41 | | | | | 847 | 88 | | | | | 18 | 1.5 | | | | | |
| | | | | 46 | | | | | 860 | 94 | | | | | 18 | 1.52 | | | | | |
| | | | | 24 | 27 | | | | 833 | 74 | | | | | 18 | 1.45 | | | | | |

RSPK PRE-SET, RING TORQUE WRENCHES

Can be used for accurate torque application even on joints inaccessible with other wrenches.

FEATURES

- The ring head of RSPK wrenches is offset at a 45° angle making certain joints particularly accessible.
- A single function wrench, used for a single setting combination of fastener size and torque setting.
- Most suited for tightening multiple same-size fasteners at the same torque on a production line.
- Setting confirmation unnecessary.
- Accuracy : ±3% of pre-set value

EXAMPLE OF ORDER

Model Size(W) Pre-set Value
 | | |
 N190RSPK 10 × 14N·m



| Model | ★1 Available sizes (W) | | | ★2 Dimensions Head | | | Model | ★3 Available sizes (W) | | | Dimensions Head | | | | |
|-------------------|------------------------|----|---|--------------------|-----|----|---------------------|------------------------|----|------|-----------------|---|---|-----|---|
| | mm | S | T | mm | S | T | | mm | S | T | mm | S | T | | |
| | | | | | | | | | | | | | | mm | S |
| 30RSPK N30RSPK | 5.5 | 4 | | 80RSPK N80RSPK | 5.5 | 4 | 190RSPK N190RSPK | 10 | 16 | 7 | | | | | |
| | 6 | 10 | 5 | | 6 | 10 | | 5 | 11 | 18 | | | | 7 | |
| | 7 | | | | 7 | | | | 12 | 19 | | | | 8 | |
| | 8 | 13 | 6 | | 8 | 13 | | 6 | 13 | 20 | | | | 8.5 | |
| | 9 | 14 | | | 9 | 14 | | | 14 | 22 | | | | 9 | |
| | 10 | 16 | 7 | | 10 | 16 | 17 | 26 | 10 | | | | | | |
| | | | | | 11 | 18 | | 19 | 29 | 10.5 | | | | | |
| | | | | | 12 | 19 | 8 | | 22 | 33 | 12 | | | | |

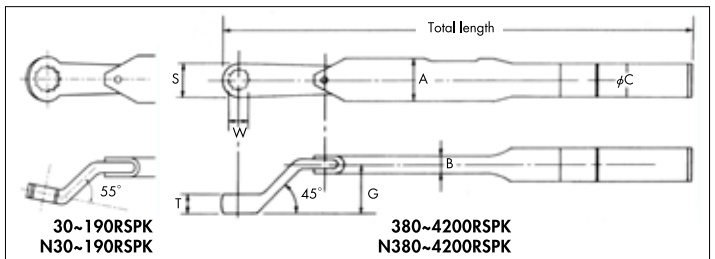

| Model (kgf·cm) | Range (kgf·cm) | Model (N·m) | Range (N·m) | Available sizes (W) | | | | Total length (mm) | Dimensions (mm) | | | | | | | Weight (kg) |
|----------------|----------------|-------------|-------------|---------------------|----|----|----|-------------------|-----------------|------|------|------|------|------|------|-------------|
| | | | | | | | | | Head | | | | Body | | | |
| | | | | S | T | G | A | B | C | | | | | | | |
| 30RSPK | 5~35 | N30RSPK | 0.5~3.5 | 5.5 | 6 | | | 175 | ★1 | | 19.5 | 7.5 | 15 | 0.12 | | |
| | | | | 7 | 8 | 9 | 10 | | | | | | | | | |
| | | | | 5.5 | 6 | 7 | | | | | | | | | | |
| | | | | 8 | 9 | 10 | | | | | | | | | | |
| 80RSPK | 20~90 | N80RSPK | 2~9 | 11 | 12 | | | 197 | ★2 | | 19.5 | 7.5 | 15 | 0.13 | | |
| | | | | 8 | 9 | 10 | | | | | | | | | | |
| | | | | 11 | 12 | | | | | | | | | | | |
| 190RSPK | 40~210 | N190RSPK | 4~21 | 10 | | | | 222 | ★3 | | 19.5 | 7.5 | 15 | 0.21 | | |
| | | | | 11 | 12 | 13 | 14 | | | | | | | | 225 | |
| | | | | 17 | 19 | 22 | | | | | | | | | | 228 |
| | | | | 11 | 12 | 13 | 14 | | | | | | | | | |
| 380RSPK | 90~420 | N380RSPK | 9~42 | 17 | 19 | 22 | | 273 | 10 | 25 | 26.6 | 8.2 | 20 | 0.31 | | |
| | | | | 14 | 17 | | | | | | | | | | 32 | |
| | | | | 17 | 19 | 22 | | | | | | | | | | |
| 670RSPK | 140~730 | N670RSPK | 14~73 | 14 | 17 | | | 343 | 26 | 12 | 27 | 25.8 | 9.7 | 20 | 0.46 | |
| | | | | 19 | 22 | 24 | | | | | | | | | | 348 |
| | | | | 27 | 30 | 32 | | | | | | | | | | |
| | | | | 19 | | | | | | | | | | | | |
| 1200RSPK | 250~1,270 | N1200RSPK | 25~127 | 19 | | | | 413 | 32 | 13 | 29 | 32.8 | 11.3 | 25 | 0.5 | |
| | | | | 22 | 24 | | | | | | | | | | | 415 |
| | | | | 27 | 30 | 32 | | | | | | | | | | |
| | | | | 36 | | | | | | | | | | | | |
| | | | | 19 | 22 | 24 | | | | | | | | | | 470 |
| 27 | 30 | 32 | | | | | | | | | | | | | | |
| 1600RSPK | 320~1,700 | N1600RSPK | 32~170 | 19 | 22 | 24 | | 474 | 37 | 15 | 31 | 32.8 | 11.3 | 25 | 1.0 | |
| | | | | 22 | 24 | 27 | | | | | | | | | | 605 |
| | | | | 30 | 32 | | | | | | | | | | | |
| 2200RSPK | 480~2,300 | N2200RSPK | 48~230 | 19 | | | | 608 | 41 | 16.5 | 33 | 35.6 | 12.5 | 27.2 | 1.2 | |
| | | | | 22 | 24 | 27 | | | | | | | | | | 610 |
| | | | | 30 | 32 | | | | | | | | | | | |
| | | | | 36 | | | | | | | | | | | | |
| | | | | 41 | | | | | | | | | | | | |
| 3100RSPK | 680~3,200 | N3100RSPK | 68~320 | 22 | | | | 682 | 40 | 35 | 38 | 16 | 30 | 1.35 | | |
| | | | | 24 | 27 | 30 | | | | | | | | | 685 | |
| | | | | 32 | 36 | | | | | | | | | | | 688 |
| | | | | 41 | | | | | | | | | | | | |
| 4200RSPK | 950~4,300 | N4200RSPK | 95~430 | 27 | 30 | 32 | | 880 | 52 | 18 | 37 | 43.3 | 17.8 | 34 | 1.4 | |
| | | | | 36 | | | | | | | | | | | | 885 |
| | | | | 41 | | | | | | | | | | | | |
| | | | | 46 | | | | | | | | | | | | |
| | | | | 46 | | | | | | | | | | | | |

QLK ADJUSTABLE, RATCHET TORQUE WRENCHES

Freely set torque values within the capacity range. Replaceable socket, ratchet wrenches.

FEATURES

- The ratchet improves efficiency. These wrenches are well suited for repetitive work.
- By replacing the sockets, various sizes of fasteners can be tightened within the tool's capacity range.
- By reversing the ratchet, the wrench can be used to loosen fasteners counter-clockwise.
- Tightening to a torque setting can only be done clockwise.
- Accuracy : ±3% of indicated value over the full range.



ADJUSTING THE TORQUE SETTING

◆ 30QLK~5600QLK

- (1) Loosen the lock screw. (See Fig.1)
- (2) Turn the sub-scale and adjust to a torque value (the main scale plus the sub-scale)(See Fig.2)
- (3) Tighten the lock screw. (If the lock screw hits the pin before completely tightening, then change the position of the pin)

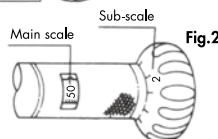
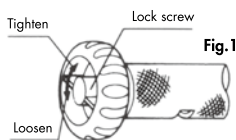

Set torque value: 50+2=52kgf·m

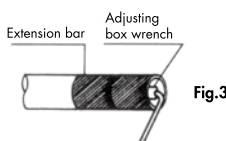

◆ 7000QLK~14000QLK

- (1) When applicable, mount the extension bar snugly all the way onto the body of the wrench.
- (2) With the extension bar mounted (See Fig.3), insert the hexagonal side of the adjusting box wrench.
- Without the extension bar (See Fig.4), insert the hexagonal side of the adjusting box wrench into the body.
- (3) Turn the adjusting box wrench to set the torque value. (the main scale plus the sub-scale)

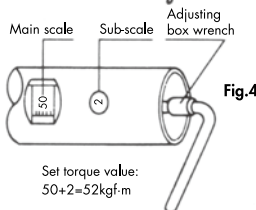

Set torque value: 50+2=52kgf·m

30~5600QLK

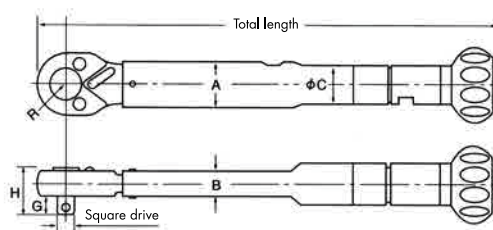

7000~21000QLK

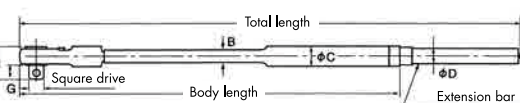

★ Torque adjusting box wrench

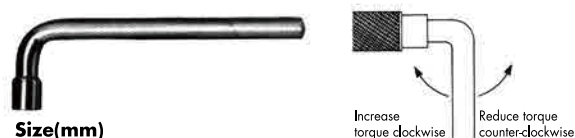

Size(mm)

| | |
|----------------------|----|
| (N)7000QLK~10000QLK | 8 |
| (N)14000QLK~21000QLK | 10 |

| Model (kgf·cm/kgf·m) | Range kgf·cm/kgf·m | Increment kgf·cm/kgf·m | Model (cN·m/N·m) | Range cN·m/N·m | Increment cN·m/N·m | Model (lbf·in) | Range lbf·in | Increment lbf·in | Square drive mm | Total length mm | Dimensions (mm) | | | | | | | | Weight kg | Standard Accessory | | |
|-------------------------|-----------------------|---------------------------|---------------------|-------------------|-----------------------|-------------------|-----------------|---------------------|-----------------------|-----------------------|-----------------|-----|------|------|------|------|------|-------|----------------|-----------------------|------|------|
| | | | | | | | | | | | Head | | | Body | | | | | | | | |
| | | | | | | | | | | | | H | G | R | A | B | C | D | Body length | | | |
| 30QLK | 10~30 | 0.5 | N30QLK | 100~300 | 5 | | | | 6.35 (1/4") | 186 | 18.8 | 7.5 | 12 | | | | | | | | 0.18 | |
| 60QLK | 20~60 | 1 | N60QLK | 2~6 | 0.1 | | | | | | | | | | | | | | | | | |
| 120QLK | 40~120 | 2 | N120QLK | 4~12 | 0.2 | PI 120QLK | 40~120 | 2 | | | | | | | | | | | | | | |
| 230QLK | 70~230 | 2 | N230QLK | 7~23 | 0.2 | PI 230QLK | 70~230 | 2 | | | | | | | | | | | | | | |
| 250QLK | 50~250 | 2 | N250QLK | 5~25 | 0.2 | | | | 9.53 (3/8") | 232 | | | 15.5 | | | | | | | | 0.27 | |
| 450QLK | 100~450 | 5 | N450QLK | 10~45 | 0.5 | PI 450QLK | 100~450 | 5 | | 253.5 | 25 | 11 | 16 | 25 | 11.4 | 20 | | | | | 0.29 | |
| 500QLK | 100~500 | 5 | N500QLK | 10~50 | 0.5 | | | | | | | | | | | | | | | | | |
| 900QLK | 200~900 | 10 | N900QLK | 20~90 | 1 | | | | | | | | | | | | | | | | | |
| 1000QLK | 200~1000 | 10 | N1000QLK | 20~100 | 1 | PI 1000QLK | 200~1000 | 10 | | | | | | | | | | | | | | |
| 1400QLK | 400~1400 | 10 | N1400QLK | 40~140 | 1 | | | | | 352 | 31 | | 19.7 | 27.5 | 12.4 | 21.7 | | | | | 0.45 | |
| 1800QLK | 400~1800 | 20 | N1800QLK | 40~180 | 2 | | | | | 392 | | 14 | | | | | | | | | | 0.79 |
| 2000QLK | 400~2000 | 20 | N2000QLK | 40~200 | 2 | PI 2000QLK | 400~2000 | 20 | | 478 | 33 | | 23 | 34 | | | | | | | | 0.85 |
| 2800QLK | 4~28 | 0.2 | N2800QLK | 40~280 | 2 | | | | | | | | | | 15.4 | 27.2 | | | | | | 1.45 |
| 3600QLK | 8~36 | 0.2 | N3600QLK | 80~360 | 2 | | | | | 678 | 42 | | 23.5 | 35 | | | | | | | | 1.9 |
| 4200QLK | 6~42 | 0.2 | N4200QLK | 60~420 | 2 | | | | | 1,314 | | | | | | | | | | | | 1.9 |
| 5600QLK | 8~56 | 0.3 | N5600QLK | 80~560 | 3 | | | | 19.05 (3/4") | 950 | 42.7 | 20 | 27 | 38 | 16 | 30 | | | | | | 3.3 |
| 7000QLK | 10~70 | 0.5 | N7000QLK | 100~700 | 5 | | | | | 1,314 | 49.5 | | 34 | 46 | 19.2 | 35.4 | 27.2 | 990 | | | | 5 |
| 8500QLK | 10~85 | 0.5 | N8500QLK | 100~850 | 5 | | | | | 1,388 | | | | | | | | | | | | 6.2 |
| 10000QLK | 10~100 | 0.5 | N10000QLK | 100~1000 | 5 | | | | | 1,538 | | | | | | | | | | | | 8.5 |
| 14000QLK | 20~140 | 1 | N14000QLK | 200~1400 | 10 | | | | | 1,844 | 58 | 27 | 38 | 54 | 23 | 42.7 | 31.8 | 1,105 | | | | 9.8 |
| 15000QLK | 20~150 | 1 | N15000QLK | 200~1500 | 10 | | | | | 1,844 | | | | | | | | | | | | 14 |
| 21000QLK | 70~210 | 1 | N21000QLK | 700~2100 | 10 | | | | 25.4 (1") | 2,064 | 61 | | 44 | 66 | 26 | 51 | 40 | 1,144 | | | | 19.5 |

GLK

ADJUSTABLE, RATCHET TORQUE WRENCHES WITH PLASTIC GRIP

Freely set torque values within the capacity range. Replaceable socket, ratchet wrenches.

FEATURES

- The ratchet improves efficiency. These wrenches are well suited for repetitive work.
- By replacing the sockets, various sizes of fasteners can be tightened within the tool's capacity range.
- By reversing the ratchet, the wrench can be used to loosen fasteners counter-clockwise.
- Tightening to a torque setting can only be done clockwise.
- Accuracy : $\pm 3\%$ of indicated value over the full range.



60~1400GLK

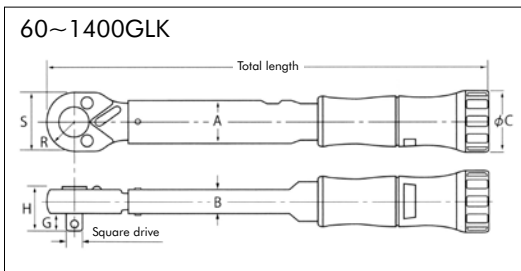

| Model (kgf·cm) | Range | Increment | Model (N·m) | Range | Increment | Square drive | Total length | Dimensions (mm) | | | | | | Weight | |
|----------------|----------|-----------|-------------|--------|-----------|--------------|--------------|-----------------|-----|------|------|------|------|--------|------|
| | | | | | | | | Head | | | Body | | | | |
| | kgf·cm | kgf·cm | | N·m | N·m | mm | mm | H | G | S | R | A | B | φ C | kg |
| 60GLK | 20~60 | 1 | N6GLK | 2~6 | 0.1 | 6.35 (1/4") | 187 | 18.8 | 7.5 | 24 | 12 | 18.2 | 9.6 | 29 | 0.2 |
| 120GLK | 40~120 | 2 | N12GLK | 4~12 | 0.2 | | | | | | | | | | 0.28 |
| 250GLK | 50~250 | 2 | N25GLK | 5~25 | 0.2 | 9.53 (3/8") | 233 | 25 | 11 | 31 | 15.5 | 25 | 11.4 | 35 | 0.47 |
| 500GLK | 100~500 | 5 | N50GLK | 10~50 | 0.5 | | 255 | | | | | | | | 0.8 |
| 1000GLK | 200~1000 | 10 | N100GLK | 20~100 | 1 | 12.7 (1/2") | 355 | 31 | 14 | 39.4 | 19.7 | 27.5 | 12.4 | 38 | 0.87 |
| 1400GLK | 400~1400 | 10 | N140GLK | 40~140 | 1 | | 395 | | | | | | | | |

BLK

ADJUSTABLE BY HEX WRENCH, RATCHET TORQUE WRENCHES WITH PLASTIC GRIP

Freely set torque values within the capacity range. Replaceable socket, ratchet wrenches.

FEATURES

- Adjusted setting torque value by her wrench.
- The ratchet improves efficiency. These wrenches are well suited for repetitive work.
- By replacing the sockets, various sizes of fasteners can be tightened within the tool's capacity range.
- By reversing the ratchet, the wrench can be used to loosen fasteners counter-clockwise.
- Tightening to a torque setting can only be done clockwise.
- Accuracy : $\pm 3\%$ of indicated value over the full range.



250~1000BLK

*Her wrench is not included

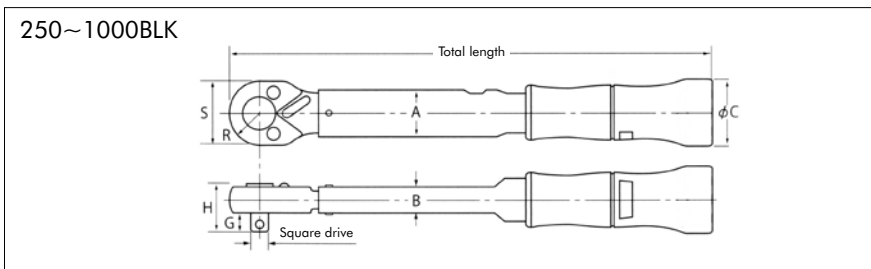

| Model (kgf·cm) | Range | Increment | Model (N·m) | Range | Increment | Square drive | Total length | Dimensions (mm) | | | | | | Weight |
|----------------|----------|-----------|-------------|--------|-----------|--------------|--------------|-----------------|----|------|------|------|----|--------|
| | | | | | | | | Head | | | Body | | | |
| | kgf·cm | kgf·cm | | N·m | N·m | mm | mm | H | G | R | A | B | C | kg |
| 250BLK | 50~250 | 2 | N25BLK | 5~25 | 0.2 | 9.53 (3/8") | 245 | 25 | 11 | 15.5 | | | 30 | 0.27 |
| 500BLK | 100~500 | 5 | N50BLK | 10~50 | 0.5 | | | | | 16 | 25 | 11.4 | 33 | 0.43 |
| 1000BLK | 200~1000 | 10 | N100BLK | 20~100 | 1 | 12.7 (1/2") | 392 | 31 | 14 | 19.7 | 27.5 | 12.4 | 36 | 0.72 |

QSPK

PRE-SET, RATCHET TORQUE WRENCHES, METAL HANDLE

Pre-set torque value. Improved work efficiency with ratchet square drive.

FEATURES

- The ratchet drive enables quickly tightening fasteners to the preset torque. Suitable for repetitive jobs.
- The wrench's inner mechanism automatically resets itself for the the next job after disengaging from a tightened joint.
- Accuracy : ±3% of set value.

EXAMPLE OF ORDER

Model Pre-set Value
 | |
 N900QSPK × 72N·m

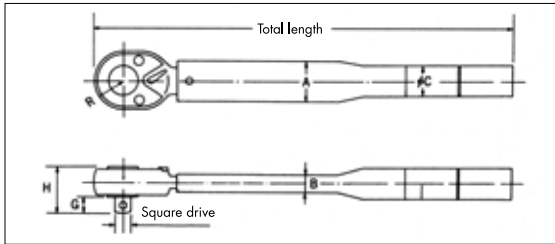

QSPK (Metal Handle)

| Model (kgf-cm) | Range kgf-cm | Model (N-m) | Range N-m | Model (lbf-in/lbf-ft) | Range lbf-in/lbf-ft | Square drive mm | Total length mm | Dimensions (mm) | | | | | | Weight kg |
|----------------|--------------|-------------|-----------|-----------------------|---------------------|-----------------|-----------------|-----------------|------|------|------|------|------|-----------|
| | | | | | | | | Head | | | Body | | | |
| | | | | | | | | H | G | R | A | B | C | |
| 60QSPK | 20~60 | N 60QSPK | 2~6 | PI 60QSPK | 20~60 lbf-in | 6.35 (1/4") | 174 | 19.5 | 7.5 | 12.5 | 18.2 | 9.6 | 15 | 0.17 |
| 120QSPK | 40~120 | N 120QSPK | 4~12 | PI 120QSPK | 40~120 " | 9.53 (3/8") | 220 | 25 | 12 | 16 | 25 | 11.4 | 20 | 0.25 |
| 230QSPK | 70~230 | N 230QSPK | 7~23 | PI 230QSPK | 70~230 " | | 240 | | | | | | | |
| 250QSPK | 70~250 | N 250QSPK | 7~25 | PI 450QSPK | 100~450 " | 12.7 (1/2") | 340 | 31 | 14 | 19.7 | 27.5 | 12.4 | 21.7 | 0.64 |
| 450QSPK | 100~450 | N 450QSPK | 10~45 | PI 1400QSPK | 400~1400 " | | 380 | | | | | | | |
| 500QSPK | 100~500 | N 500QSPK | 10~50 | PI 1800QSPK | 400~1800 " | | 463.5 | 33 | 20 | 23 | 34 | 15.4 | 27.2 | 1.35 |
| 900QSPK | 200~900 | N 900QSPK | 20~90 | PI 2800QSPK | 600~2800 " | | 664 | | | | | | | |
| 1000QSPK | 200~1000 | N 1000QSPK | 20~100 | PF 4200QSPK | 50~300 lbf-ft | 980 | 49.5 | 34 | 43.5 | 18 | 34 | 34 | 4.3 | |
| 1400QSPK | 400~1400 | N 1400QSPK | 40~140 | | | | | | | | | | | |
| 1800QSPK | 400~1800 | N 1800QSPK | 40~180 | | | | | | | | | | | |
| 2000QSPK | 400~2000 | N 2000QSPK | 40~200 | | | | | | | | | | | |
| 2800QSPK | 600~2800 | N 2800QSPK | 60~280 | | | | | | | | | | | |
| 4200QSPK | 600~4200 | N 4200QSPK | 60~420 | | | | | | | | | | | |

QSPKH, QSPK-A

PRE-SET, RATCHET TORQUE WRENCHES WITH PLASTIC GRIP

Pre-set torque value. Improved work efficiency with ratchet square drive.

FEATURES

- The ratchet drive enables quickly tightening fasteners to the preset torque. Suitable for repetitive jobs.
- The wrench's inner mechanism automatically resets itself for the the next job after disengaging from a tightened joint.
- Accuracy : ±3% of set value.



(N)60~1400QSPKH, QSPK-A (with Rubber Grip)

■ H-type : The end cap is removed with a slotted screwdriver to adjust torque.

| Model (kgf-cm/kgf-m) | Range kgf-cm | Model (cN-m/N-m) | Range N-m | Square drive mm | Total length mm | Dimensions (mm) | | | | | | Weight kg |
|----------------------|--------------|------------------|-----------|-----------------|-----------------|-----------------|-----|------|------|------|------|-----------|
| | | | | | | Head | | | Body | | | |
| | | | | | | H | G | R | A | B | C | |
| 60QSPKH | 20~60 | N60QSPKH | 2~6 | 6.35 (1/4") | 174 | 19.5 | 7.5 | 12.5 | 18.2 | 9.6 | 26.5 | 0.19 |
| 120QSPKH | 40~120 | N120QSPKH | 4~12 | 9.53 (3/8") | 220 | 25 | 12 | 16 | 25 | 11.4 | 32.7 | 0.27 |
| 250QSPKH | 70~250 | N250QSPKH | 7~25 | | 240 | | | | | | | 0.41 |
| 500QSPKH | 100~500 | N500QSPKH | 10~50 | 12.7 (1/2") | 340 | 31 | 14 | 19.7 | 27.5 | 12.4 | 37 | 0.69 |
| 1000QSPKH | 200~1000 | N1000QSPKH | 20~100 | | 380 | | | | | | | 0.75 |
| 1400QSPKH | 400~1400 | N1400QSPKH | 40~140 | | | | | | | | | |

■ H-type : The end cap is removed with a slotted screwdriver to adjust torque.

| Model (kgf-cm/kgf-m) | Range kgf-cm | Model (cN-m/N-m) | Range N-m | Square drive mm | Total length mm | Dimensions (mm) | | | | | | Weight kg |
|----------------------|--------------|------------------|-----------|-----------------|-----------------|-----------------|-----|------|------|------|------|-----------|
| | | | | | | Head | | | Body | | | |
| | | | | | | H | G | R | A | B | C | |
| 60QSPK-A | 20~60 | N60QSPK-A | 2~6 | 6.35 (1/4") | 174 | 19.5 | 7.5 | 12.5 | 18.2 | 9.6 | 26.5 | 0.19 |
| 120QSPK-A | 40~120 | N120QSPK-A | 4~12 | 9.53 (3/8") | 220 | 25 | 12 | 16 | 25 | 11.4 | 32.7 | 0.27 |
| 250QSPK-A | 70~250 | N250QSPK-A | 7~25 | | 240 | | | | | | | 0.41 |
| 500QSPK-A | 100~500 | N500QSPK-A | 10~50 | 12.7 (1/2") | 340 | 31 | 14 | 19.7 | 27.5 | 12.4 | 37 | 0.69 |
| 1000QSPK-A | 200~1000 | N1000QSPK-A | 20~100 | | 380 | | | | | | | 0.75 |
| 1400QSPK-A | 400~1400 | N1400QSPK-A | 40~140 | | | | | | | | | |

Note : Use a KANON torque wrench analyzer when adjusting torque. Without the analyzer, torque cannot be adjusted.



QSPKH

*Adjusting tool is option



QSPK-A

*Hex wrench is option

SPCK PRE-SET, REPLACEABLE HEAD TORQUE WRENCHES

Work at a set torque value can proceed smoothly while using various replaceable heads.

FEATURES

- Replaceable ratchet, open end wrench, ring, and hex drive heads are available.
- Pre-set torque wrench well suited for repetitive jobs at the specified torque value.
- Accuracy : $\pm 3\%$ of pre-set value

USING AN SPCK

Mount the head on the drive.

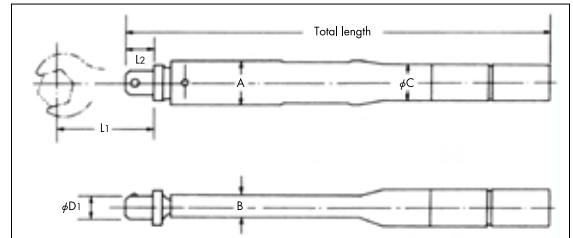

| Model (kgf·cm) | Range (kgf·cm) | Model (N·m) | Range (N·m) | Total length (mm) | Dimensions (mm) | | | | | | Weight (kg) | Replaceable heads | | | | |
|----------------|----------------|-------------|-------------|-------------------|-----------------|-----|----|------|------|----------|-------------|----------------------------|-----------|-----------|--------|-----|
| | | | | | Head | | | Body | | | | | | | | |
| | | | | | ϕD_1 | L1 | L2 | A | B | ϕC | | | | | | |
| 60SPCK | 20~60 | N60SPCK | 2~6 | 161 | 10 | 45 | 13 | 18.2 | 9.6 | 15 | 0.15 | 120QCK,230 { SCK, RCK, HCK | | | | |
| 120SPCK | 40~120 | N120SPCK | 4~12 | | | | | | | | | 230 (QCK, SCK, RCK, HCK) | | | | |
| 230SPCK | 70~230 | N230SPCK | 7~23 | 196 | 12 | 55 | 16 | 25 | 11.4 | 20 | 0.27 | 450 (QCK, SCK, RCK, HCK) | | | | |
| 250SPCK | 70~250 | N250SPCK | 7~25 | | | | | | | | | 900SPCK | 200~900 | N900SPCK | 20~90 | 312 |
| 450SPCK | 100~450 | N450SPCK | 10~45 | 220 | 15 | 65 | 18 | 27.5 | 12.4 | 21.7 | 0.57 | 1800 (QCK, SCK, RCK, HCK) | | | | |
| 500SPCK | 100~500 | N500SPCK | 10~50 | | | | | | | | | 2000SPCK | 400~2,000 | N2000SPCK | 40~200 | 428 |
| 900SPCK | 200~900 | N900SPCK | 20~90 | 312 | 15 | 65 | 18 | 27.5 | 12.4 | 21.7 | 0.57 | 2800 (QCK, SCK, RCK, HCK) | | | | |
| 1000SPCK | 200~1,000 | N1000SPCK | 20~100 | | | | | | | | | 4400SPCK | 600~4,400 | N4400SPCK | 60~440 | 893 |
| 1800SPCK | 400~1,800 | N1800SPCK | 40~180 | 428 | 18 | 80 | 22 | 34 | 15.4 | 27.2 | 0.92 | 4400 (QCK, SCK, RCK) | | | | |
| 2000SPCK | 400~2,000 | N2000SPCK | 40~200 | | | | | | | | | 2800 (QCK, SCK, RCK, HCK) | | | | |
| 2800SPCK | 600~2,800 | N2800SPCK | 60~280 | 590 | 22 | 100 | 27 | 38 | 16 | 30 | 1.7 | 4400 (QCK, SCK, RCK) | | | | |
| 4400SPCK | 600~4,400 | N4400SPCK | 60~440 | | | | | | | | | 893 | 22 | 100 | 27 | 39 |

SPCKH PRE-SET, REPLACEABLE HWAD TORQUE WRENCHES WITH PLASTIC GRIP

Work at a set torque value can proceed smoothly while using various replaceable heads.



Optional Replaceable Heads (Refer to the page 12)



| Model (kgf·cm) | Range (kgf·cm) | Model (N·m) | Range (N·m) | Total length (mm) | Dimensions (mm) | | | | | | Weight (kg) | Replaceable heads |
|----------------|----------------|-------------|-------------|-------------------|-----------------|----|----|------|------|----------|-------------|----------------------------|
| | | | | | Head | | | Body | | | | |
| | | | | | ϕD_1 | L1 | L2 | A | B | ϕC | | |
| 60SPCKH | 20~60 | N60SPCKH | 2~6 | 161 | 10 | 45 | 13 | 18.2 | 9.6 | 26.5 | 0.17 | 120QCK,230 { SCK, RCK, HCK |
| 120SPCKH | 04~120 | N120SPCKH | 4~12 | | | | | | | | | 230 (QCK, SCK, RCK, HCK) |
| 250SPCKH | 70~250 | N250SPCKH | 7~25 | 196 | 12 | 55 | 16 | 25 | 11.4 | 32.7 | 0.3 | 450 (QCK, SCK, RCK, HCK) |
| 500SPCKH | 100~500 | N500SPCKH | 10~50 | | | | | | | | | 900 (QCK, SCK, RCK, HCK) |
| 1000SPCKH | 200~1,000 | N1000SPCKH | 20~100 | 312 | 15 | 65 | 18 | 27.5 | 12.4 | 37 | 0.62 | 900 (QCK, SCK, RCK, HCK) |

RE-SETTING THE PRE-SET TORQUE

(SPK · RSPK · QSPK · SPCK · TYPES)

- (1) Remove the screw cap with a slot drive screw driver.
- (2) Loosen the setting screw with a hex wrench.
- (3) Using the special adjusting tool or equivalent, rotate the slotted plate clockwise to increase torque or counterclockwise to reduce torque. Check the setting with a torque analyzer.
- (4) Tighten the setting screw with a hex wrench.
- (5) Screw on the screws cap and tighten it.

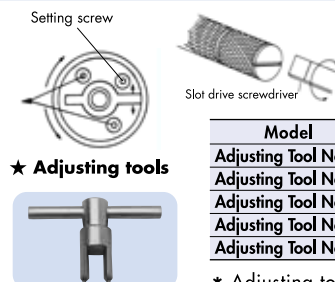

| Model | Applicable Torque wrench Tools |
|---------------------|---|
| Adjusting Tool No.1 | (N)30,80,190SPK(H), (N)30,80,190RSPK(H), (N)60,120,230,250QSPK(H) |
| Adjusting Tool No.2 | (N)380,670SPK(H), (N)380,670RSPK(H), (N)450,500,900,1000,1400QSPK(H) |
| Adjusting Tool No.3 | (N)1200,1600,2200SPK, (N)1200,1600,2200RSPK, (N)1800,2000QSPK, (N)2800 QSPK |
| Adjusting Tool No.4 | (N)3100SPK, (N)3100RSPK, (N)4200QSPK |
| Adjusting Tool No.5 | (N)4200SPK, (N)4200RSPK |

* Adjusting tool is option.

LCK

ADJUSTABLE, REPLACEABLE HEAD TORQUE WRENCHES

Freely replace heads according to work applications. The combination of replaceable heads and torque adjustability make this series extremely versatile.

FEATURES

- Ring, ratchet, open end wrench and hex drive heads are available.
- The torque can be set to any value within the capacity range.
- Models are available ranging from 20 kgf-cm to 14,000 kgf-cm.
- Accuracy : $\pm 3\%$ of indicated value over the full range

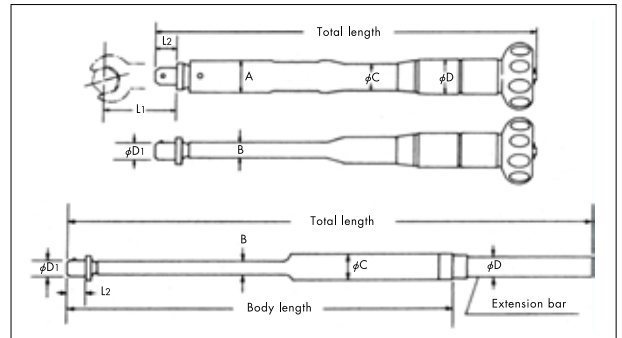

| Model (kgf-cm/kgf-m) | Range kgf-cm/kgf-m | Increment kgf-cm/kgf-m | Model (N-m) | Range N-m | Increment N-m | Total length mm | Dimensions (mm) | | | | | | | | Body length mm | Weight kg | Replaceable heads |
|----------------------|--------------------|------------------------|-------------|-----------|---------------|-----------------|-----------------|-----|----|------|------|------|------|------|----------------|-----------|---------------------------|
| | | | | | | | Head | | | Body | | | | | | | |
| | | | | | | | ϕD_1 | L1 | L2 | A | B | C | D | | | | |
| 60LCK | 20-60 kgf-cm | 1 kgf-cm | N60LCK | 2~6 | 0.1 | 173 | 10 | 45 | 13 | 18.2 | 9.6 | 15 | | | | 0.17 | 120QCK,230 { SCK, RCK HCK |
| 120LCK | 40-120 " | 2 " | N120LCK | 4~12 | 0.2 | | | | | | | | | | | | |
| 230LCK | 70-230 " | 2 " | N230LCK | 7~23 | 0.2 | 208 | 12 | 55 | 16 | 25 | 11.4 | 20 | | | | 0.2 | 230 (QCK, SCK, RCK, HCK) |
| 450LCK | 100-450 " | 5 " | N450LCK | 10~45 | 0.5 | | | | | | | | | | | | |
| 900LCK | 200-900 " | 10 " | N900LCK | 20-90 | 1 | 325 | 15 | 65 | 18 | 27.5 | 12.4 | 21.7 | | | | 0.36 | 450 (QCK, SCK, RCK, HCK) |
| 1800LCK | 400-1,800 " | 20 " | N1800LCK | 40~180 | 2 | | | | | | | | | | | | |
| 2800LCK | 4~28 kgf-m | 0.2 kgf-m | N2800LCK | 40~280 | 2 | 648 | 22 | 100 | 27 | 35 | 15.4 | 27.2 | | | | 0.59 | 900 (QCK, SCK, RCK, HCK) |
| 4400LCK | 6~44 " | 0.2 " | N4400LCK | 60~440 | 2 | | | | | | | | | | | | |
| 5600LCK | 8~56 " | 0.3 " | N5600LCK | 80~560 | 3 | 1086 | 30 | 125 | 45 | 43.5 | 18 | 34 | | | | 1.3 | 1800 (QCK, SCK, RCK, HCK) |
| 7000LCK | 10~70 " | 0.5 " | N7000LCK | 100~700 | 5 | | | | | | | | | | | | |
| 8500LCK | 10~85 " | 0.5 " | N8500LCK | 100~850 | 5 | 1267 | 34 | 130 | 47 | 54 | 23 | 42.7 | 31.8 | 984 | | 1.8 | 2800 (QCK, SCK, RCK, HCK) |
| 10000LCK | 10~100 " | 0.5 " | N10000LCK | 100~1000 | 5 | | | | | | | | | | | | |
| 14000LCK | 20~140 " | 1 " | N14000LCK | 200~1400 | 10 | 1700 | 38 | 160 | 60 | 66 | 26 | 51 | 40 | 1003 | | 2.8 | 4400 (QCK, SCK, RCK) |
| | | | | | | | | | | | | | | | | 4.9 | 7000 (QCK, SCK, RCK) |
| | | | | | | | | | | | | | | | | 4.9 | |
| | | | | | | | | | | | | | | | | 7.2 | 10000 (QCK, SCK, RCK) |
| | | | | | | | | | | | | | | | | 7.5 | |

GCK

ADJUSTABLE, REPLACEABLE HEAD TORQUE WRENCHES

Freely replace heads according to work applications. The combination of replaceable heads and torque adjustability make this series extremely versatile.

FEATURES

- Ring, ratchet, open end wrench and hex drive heads are available.
- The torque can be set to any value within the capacity range.
- Models are available ranging from 20 kgf-cm to 1,400 kgf-cm.
- Accuracy : $\pm 3\%$ of indicated value over the full range

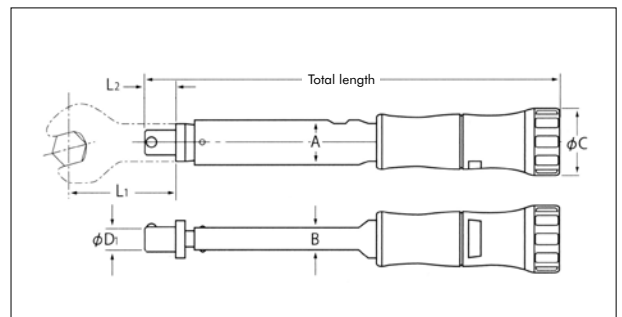

| Model (kgf-cm) | Range kgf-cm | Increment kgf-cm | Model (N-m) | Range N-m | Increment N-m | Total length mm | Dimensions (mm) | | | | | | Weight kg | Replaceable heads | |
|----------------|--------------|------------------|-------------|-----------|---------------|-----------------|-----------------|----|----|------|------|----|-----------|-------------------|---------------------------|
| | | | | | | | Head | | | Body | | | | | |
| | | | | | | | ϕD_1 | L1 | L2 | A | B | C | | | |
| 60GCK | 20-60 | 1 | N6GCK | 2~6 | 0.1 | 174 | 10 | 45 | 13 | 18.2 | 9.6 | 29 | | 0.18 | 120QCK,230 { SCK, RCK HCK |
| 120GCK | 40-120 | 2 | N12GCK | 4~12 | 0.2 | | | | | | | | | | |
| 250GCK | 50-250 | 2 | N25GCK | 5~25 | 0.2 | 209 | 12 | 55 | 16 | 25 | 11.4 | 35 | | 0.21 | 230 (QCK, SCK, RCK, HCK) |
| 500GCK | 100-450 | 5 | N50GCK | 10~45 | 0.5 | | | | | | | | | | |
| 1000GCK | 200-900 | 10 | N100GCK | 20~90 | 1 | 327 | 15 | 65 | 18 | 27.5 | 12.4 | 38 | | 0.37 | 450 (QCK, SCK, RCK, HCK) |
| 1400GCK | 400~1400 | 20 | N140GCK | 40~140 | 2 | | | | | | | | | | |
| | | | | | | | | | | | | | | 0.6 | 900 (QCK, SCK, RCK, HCK) |
| | | | | | | | | | | | | | | 0.68 | |

QLK-LR LARGE HUB NUT TORQUE WRENCHES

Ideal for tightening hub nuts on large trucks and buses

FEATURES

- Dual square drives for both clockwise and counterclockwise tightening.
- By replacing the sockets, various sizes of fasteners can be tightened within the tool's capacity range.
- By reversing the switch on the ratchet, the wrench can be used to loosen fasteners. Tightening to a torque setting, however, can only be done in the direction of the arrow.
- Accuracy : $\pm 3\%$ of indicated value over the full range

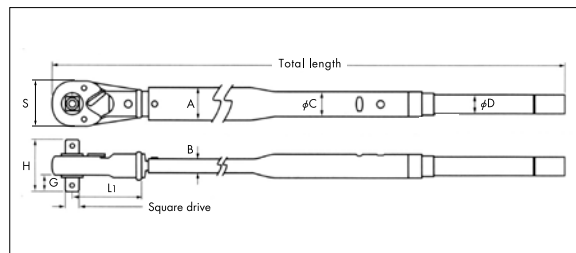

| Model (kgf-m) | Range | Increment | Model (N-m) | Range | Increment | Square drive | Total length | Dimensions (mm) | | | | | | | | Weight | Standard Accessory |
|---------------|--------|-----------|--------------|----------|-----------|--------------|--------------|-----------------|----|-----|-----|------|------|------|------|--------|--------------------|
| | | | | | | | | Head | | | | Body | | | | | |
| kgf-m | | | N-m | | mm | mm | S | G | H | L1 | A | B | φC | φD | kg | | |
| 7000QLK-LR | 10~70 | 0.5 | N7000QLK-LR | 100~700 | 5 | 19.05 (3/4") | 1,314 | 68 | 20 | 70 | 125 | 49 | 20 | 35.4 | 27.2 | 6.2 | |
| 8500QLK-LR | 10~85 | | N8500QLK-LR | 100~850 | | 1,388 | 76 | 27 | 85 | 168 | 54 | 23 | 42.7 | 31.8 | 8.5 | | |
| 10000QLK-LR | 10~100 | | N10000QLK-LR | 100~1000 | | 1,538 | | | | | | | | | 8.8 | | |



| Model (Replaceable Head) | Square drive mm | Applicable torque wrench |
|--------------------------|-----------------|--------------------------|
| 7000QCK-LR | 19.05 (3/4") | (N)5600~7000LCK |
| 10000QCK-LR | 25.4 (1") | (N)8500~10000LCK |

HYK ADJUSTABLE WRENCH HEADS, ADJUSTABLE TORQUE WRENCHES

Built-in "no play" worm screw

FEATURES

- Since the head can be taken off and reversed, the wrench can be used in confined spaces (in as small as a 30 degree turn) previously inaccessible to even other adjustable wrenches. (Tightening to a torque setting can only be done in the direction of the arrow.)
- There is hardly any play in the worm screw adjuster in the wrench head, which will improve your working efficiency. Without excess play, the torque wrench will not damage the corners of fasteners like ordinary wrenches will.
- Accuracy : $\pm 4\%$ of indicated value over the full range

USING AN HYK

■ Setting the opening

- (1) Slide the jaws onto the fastener until it contacts the spring pin. (a)
- (2) Tighten the adjusting worm screw so the jaws grip the fastener. (b)
- (3) Loosen the adjusting worm screw just enough to allow removing the wrench from the fastener. (c)

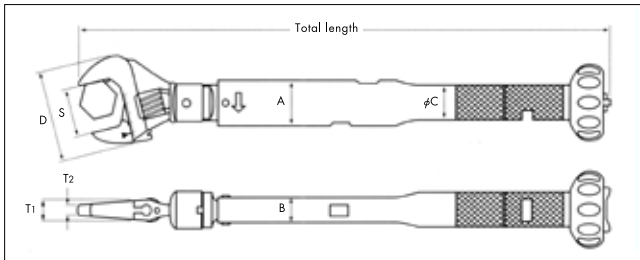
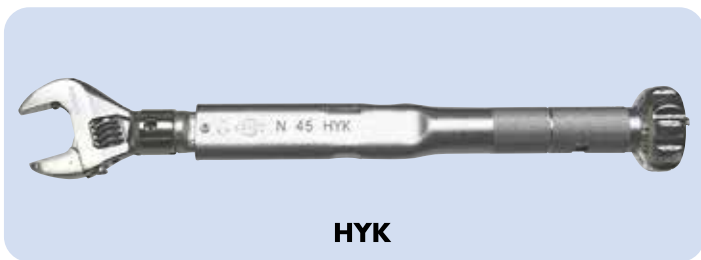
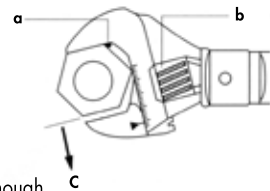

| Model (kgf-cm) | Range | Increment | Model (N-m) | Range | Increment | Total length | Opening Size (mm) | Dimensions (mm) | | | | | | | Weight |
|----------------|----------|-----------|-------------|--------|-----------|--------------|-------------------|-----------------|------|-----|------|------|------|-------|--------|
| | | | | | | | | Head | | | | Body | | | |
| kgf-cm | | | N-m | | mm | S | D | T1 | T2 | A | B | φC | g | | |
| 450HYK | 100~450 | 5 | N45HYK | 10~45 | 0.5 | 285 | 10~25 | 48 | 10 | 5.5 | 25 | 11.4 | 20 | 460 | |
| 900HYK | 200~900 | 10 | N90HYK | 20~90 | 1 | 386 | 10~30 | 58 | 12 | 6.0 | 27.5 | 12.4 | 21.7 | 740 | |
| 1800HYK | 400~1800 | 20 | N180HYK | 40~180 | 2 | 518 | 17~38 | 66 | 12.5 | 6.5 | 34 | 15.4 | 27.2 | 1,420 | |

■ MCK

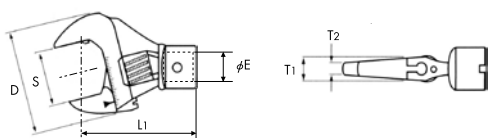

| Model (Replaceable Head) | Opening Size (mm) | Dimensions (mm) | | | | | Applicable torque wrench | |
|--------------------------|-------------------|-----------------|----|----|----|-----|--|--|
| | S | D | φE | L1 | T1 | T2 | | |
| 45MCK | 10~25 | 48 | 12 | 57 | 10 | 5.5 | (N)450LCK, (N)450-500SPCK, (N)500FCK, DTC-500EXL, DTC-N50EXL | |
| 90MCK | 10~30 | 58 | 15 | 65 | 12 | 6 | (N)900LCK, (N)900-1000SPCK, (N)1000FCK, DTC-1000EXL, DTC-N100EXL | |
| 180MCK | 17~38 | 66 | 18 | 80 | 13 | 6.5 | (N)1800LCK, (N)1800-2000SPCK, (N)1500FCK, DTC-2000EXL, DTC-N200EXL | |



INDICATOR PLATE TORQUE WRENCHES

Quite suitable for general tightening and for checking torque on previously tightened joints. A popular series with fan-shaped indicator plate scales.

FEATURES

- The simple structure and small friction area give this series of tools a long life.
- Strong and easy to handle.
- Accuracy : $\pm 3\%$ of indicated value over the full range

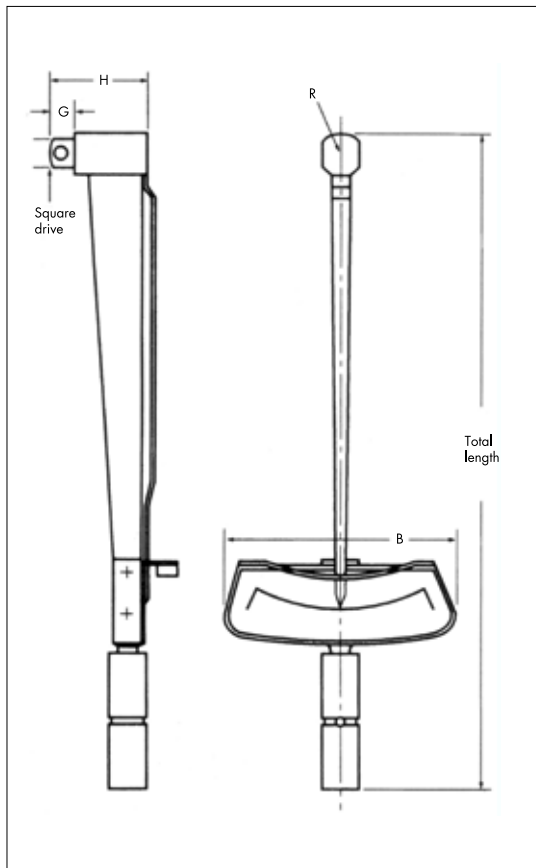

FK

| Model (kgf·cm) | Range (CW/CCW) kgf·cm | Increment | Model (cN·m/N·m) | Range (CW/CCW) cN·m/N·m | Increment | Sq. drive mm | Total length mm | Dimensions (mm) | | | | Weight kg |
|----------------|-----------------------|-----------|------------------|-------------------------|-----------|--------------|-----------------|-----------------|-----|------|------|-----------|
| | | | | | | | | Head | | Body | | |
| | | | | | | | | H | G | R | B | |
| 4FK | 1~4 | 0.2 | N4FK | 10~40 cN·m | 2 cN·m | 6.35 (1/4") | 110 | 26 | 7.5 | 5 | 54 | 0.05 |
| 7FK | 1~7 | 0.2 | N7FK | 10~70 " | 2 " | | 132 | | | | 0.05 | |
| 15FK | 5~15 | 0.5 | N15FK | 50~150 " | 5 " | | 140 | | | | 0.08 | |
| 30FK | 10~30 | 1 | N30FK | 1~3 N·m | 0.1 N·m | | 170 | | | | 32 | 0.1 |
| 60FK | 10~60 | 2 | N60FK | 1~6 " | 0.2 " | | 190 | | | | 36.5 | 0.22 |
| 120FK | 20~120 | 5 | N120FK | 2~12 " | 0.5 " | 237 | 43.5 | 0.25 | | | | |
| 230FK | 30~230 | 5 | N230FK | 3~23 " | 0.5 " | 290 | 42 | 11 | 9 | 106 | 0.3 | |
| 450FK | 50~450 | 10 | N450FK | 5~45 " | 1 " | 320 | | | | | 0.34 | |
| 900FK | 100~900 | 20 | N900FK | 10~90 " | 2 " | 388 | 12.7 (1/2") | 58 | 14 | 12.5 | 114 | 1.1 |
| 1300FK | 200~1,300 | 20 | N1300FK | 20~130 " | 2 " | 441 | | | | | 1.2 | |
| 1800FK | 300~1,800 | 50 | N1800FK | 30~180 " | 5 " | 487 | | | | | 1.3 | |
| 2800FK | 500~2,800 | 50 | N2800FK | 50~280 " | 5 " | 19.05 (3/4") | 587 | 82 | 20 | 15 | 124 | 2.6 |
| 4200FK | 700~4,200 | 100 | N4200FK | 70~420 " | 10 " | | 853 | | | | | 3.5 |
| 5600FK | 1,000~5,600 | 100 | N5600FK | 100~560 " | 10 " | | 946 | | | | | 4.4 |
| 7000FK | 1,000~7,000 | 100 | N7000FK | 100~700 " | 10 " | 1172 | 25.4 (1") | 76.5 | 27 | 32 | 186 | 6.7 |
| 8500FK | 1,500~8,500 | 200 | N8500FK | 150~850 " | 20 " | 1387 | | | | | | 8.0 |
| 10000FK | 2,000~10,000 | 200 | N10000FK | 200~1,000 " | 20 " | 1578 | | | | | | 13.3 |
| 15000FK | 3,000~15,000 | 200 | N15000FK | 300~1,500 " | 20 " | 1973 | 17.0 | | | | | |

MLQK MARKING TORQUE WRENCHES

No tightening negligence with marking check.

FEATURES

- To click torque wrench and the bolt is painted. No marking without click.
- 6000 times can be marked with 14 to 24mm socket.
- 1500 times can be marked with 8 to 13mm socket.
- Easy maintenance.
- Accuracy : $\pm 3\%$
- Please select the size of socket when you order MQLK. Socket is modified for MQLK

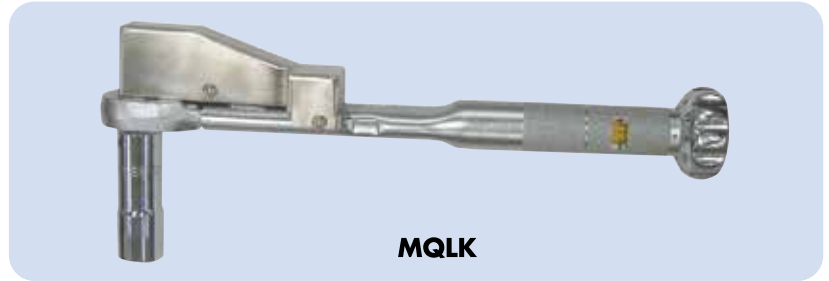

MLQK

* Ink is not included

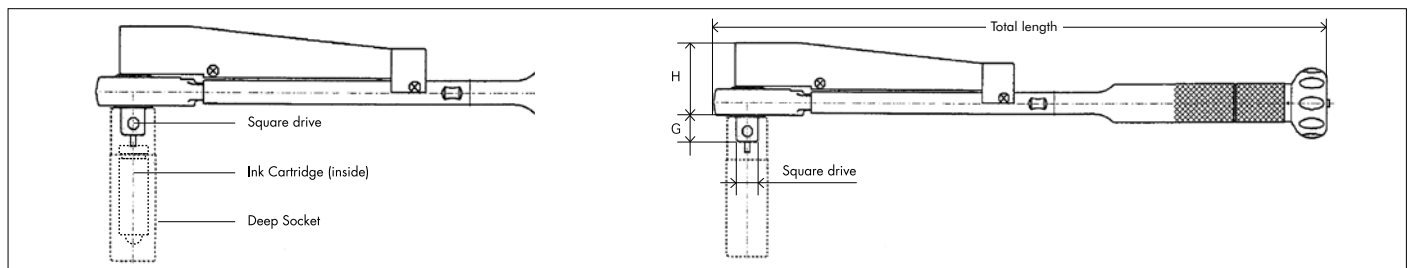

| Model (kgf-cm) | Range (CW/CCW) kgf-cm | Increment | Model (N·m) | Range (CW/CCW) N·m | Increment | Square drive mm | Total length mm | Dimensions (mm) Head | | Weight kg | Optional socket mm |
|----------------|-----------------------|-----------|-------------|--------------------|-----------|-----------------|-----------------|----------------------|----|-----------|--------------------|
| | | | | | | | | H | G | | |
| 250MQLK | 70~250 | 0.2 | N250MQLK | 7~25 | 0.2 | 9.53 | 232 | 54 | 11 | 0.37 | 8~24 |
| 500MQLK | 100~500 | 0.5 | N500MQLK | 10~50 | 0.5 | (3/8") | 254 | 54 | 11 | 0.55 | 8~24 |
| 1000MQLK | 200~1000 | 1 | N1000MQLK | 20~100 | 1 | 12.7 | 352 | 57 | 14 | 0.89 | 13~24 |
| 1400MQLK | 400~1400 | 1 | N1400MQLK | 40~140 | 1 | (1/2") | 392 | 57 | 14 | 0.95 | 13~24 |

MLQK-E HEXAGON MARKING TORQUE WRENCHES

No tightening negligence with marking check.

FEATURES

- A mark is automatically painted when the specified torque is reached; an electric signal is triggered to pop up the paint marker at the tip of the wrench to mark.
- Marking position is finely adjustable front to back and side to side. Marks can also be printed on the side of a socket bolt, or the head or periphery of a buried bolt.



MLQK-E

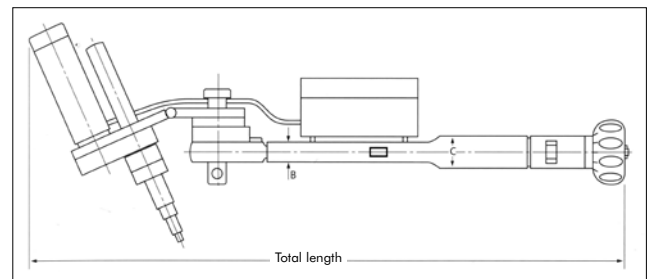

BATTERY CHARGER SPECIFICATIONS

- Input : 100-240VAC, 50/60Hz
- Cell : 2S and 3S
- Output current : 3 × 850mA

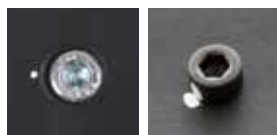

| Model (kgf-cm) | Range kgf-cm | Increment kgf-cm | Model (cN·m/N·m) | Range N·m | Increment N·m | Square drive mm | Total length mm | Dimensions (mm) | | Weight kg |
|----------------|--------------|------------------|------------------|-----------|---------------|-----------------|-----------------|-----------------|----|-----------|
| | | | | | | | | B | C | |
| 60MQLK-E | 20~60 | 1 | N60MQLK-E | 2~6 | 0.1 | 9.53 (3/8") | 327 | 10 | 15 | 0.7 |
| 120MQLK-E | 40~120 | 2 | N120MQLK-E | 4~12 | 0.2 | | | | | 0.8 |
| 250MQLK-E | 70~250 | 2 | N250MQLK-E | 7~25 | 0.2 | | | | | 1 |
| 500MQLK-E | 100~500 | 5 | N500MQLK-E | 10~50 | 0.5 | 12.7 (1/2") | 349 | 12 | 22 | 1.3 |
| 1000MQLK-E | 200~1000 | 10 | N1000MQLK-E | 20~100 | 1 | 452 | 1.4 | | | |
| 1400MQLK-E | 400~1400 | 10 | N1400MQLK-E | 40~140 | 1 | 492 | 1.4 | | | |

TOK-G DIAL INDICATOR TORQUE WRENCHES

Easy to read dial indicator. Well suited for inspection and general maintenance service.

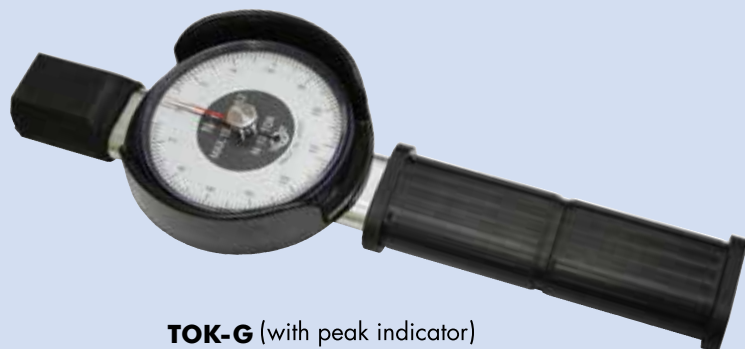

TOK-G (with peak indicator)



FEATURES

- Oval design with comfort rubber grip reduces strain.
- Easily readable for inspections.
- Useful for general tightening work.
- Accuracy : $\pm 3\%$ of indicated value over the full range

USING A TOK WRENCH

- (1) Turn the dial cap and set the indicator to 0.
 - (2) Mount a socket on the square drive.
 - (3) Tighten until the indicator points to the desired torque.
- * When using a peak indicator wrench, set it to 0 before tightening.

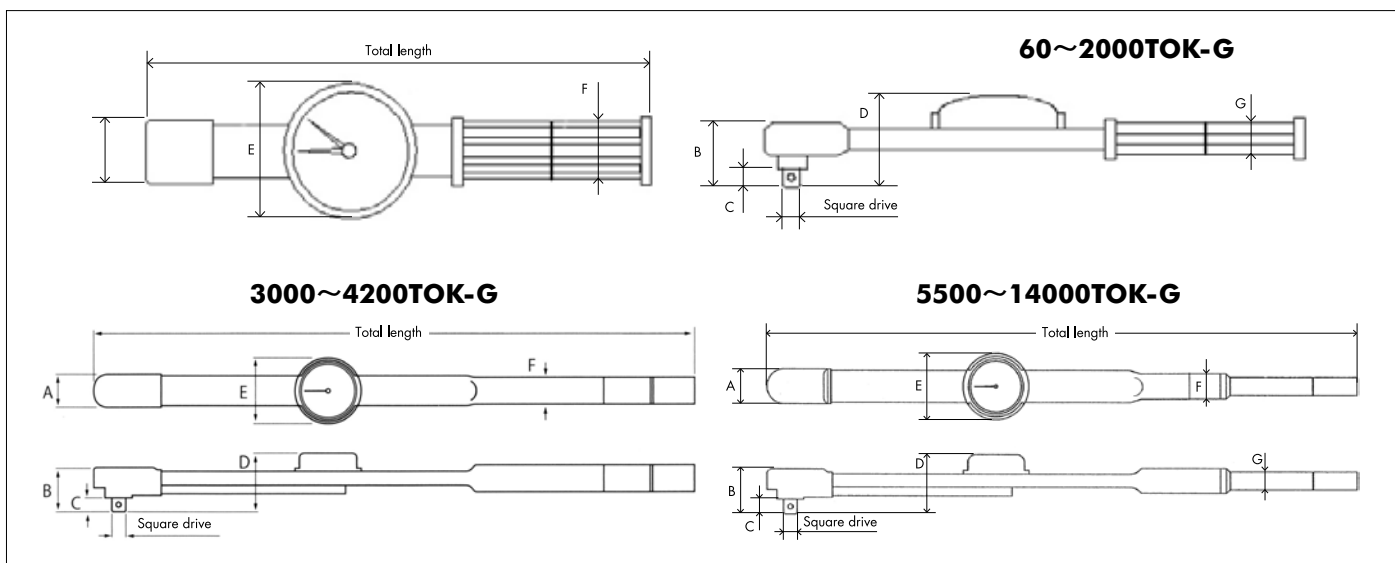

* 14000TOK-G and N1400TOK-G do not have the rubber head.

| Model (kgf-cm/kgf-m) | Range (CW/CCW) kgf-cm/kgf-m | Increment | Model (N·m) | Range (CW/CCW) N-m | Increment | Square drive mm | Total length mm | Dimensions (mm) | | | | | | | Weight kg |
|-------------------------|-----------------------------------|-----------|----------------|--------------------------|-----------|--------------------|--------------------|-----------------|------|-----|------|----|-----|------|--------------|
| | | | | | | | | Head | | | Body | | | | |
| | | | | | | | | A | B | C | D | E | F | G | |
| 60TOK-G | 6~60 kgf-cm | 1 kgf-cm | N6TOK-G | 0.6~6 | 0.1 | 6.35 | 260 | 35 | 38.5 | 7.5 | 58 | 90 | 37 | 21.5 | 0.5 |
| 120TOK-G | 10~120 " | 2 " | N12TOK-G | 1~12 | 0.2 | (1/4") | 260 | 35 | 38.5 | 7.5 | 58 | 90 | 37 | 21.5 | 0.5 |
| 300TOK-G | 50~300 " | 5 " | N30TOK-G | 5~30 | 0.5 | 9.53 (3/8") | 323 | 35 | 43 | 11 | 60 | 90 | 37 | 21.5 | 0.61 |
| 500TOK-G | 50~500 " | 5 " | N50TOK-G | 5~50 | 0.5 | | 323 | 35 | 43 | 11 | 60 | 90 | 37 | 21.5 | 0.61 |
| 700TOK-G | 100~700 " | 10 " | N70TOK-G | 10~70 | 1 | 12.7 (1/2") | 323 | 35 | 43 | 11 | 60 | 90 | 37 | 21.5 | 0.61 |
| 1400TOK-G | 200~1400 " | 20 " | N140TOK-G | 20~140 | 2 | | 463 | 39 | 49 | 14 | 65 | 90 | 41 | 22.5 | 0.87 |
| 2000TOK-G | 200~2000 " | 20 " | N200TOK-G | 20~200 | 2 | 19.05 (3/4") | 463 | 39 | 49 | 14 | 65 | 90 | 41 | 22.5 | 0.87 |
| 3000TOK-G | 3~30 kgf-m | 0.5 kgf-m | N300TOK-G | 30~300 | 5 | | 682 | 41 | 55 | 20 | 77 | 90 | φ30 | 1.6 | |
| 4200TOK-G | 4~42 " | 1 " | N420TOK-G | 40~420 | 10 | 25.4 (1") | 955 | 48 | 60 | 20 | 77 | 90 | φ34 | 2.5 | |
| 5500TOK-G | 5~55 " | 1 " | N550TOK-G | 50~550 | 10 | | 1110 | 50 | 60 | 20 | 80 | 90 | φ38 | 3.8 | |
| 7000TOK-G | 7~70 " | 1 " | N700TOK-G | 70~700 | 10 | 25.4 (1") | 1280 | 54 | 64 | 20 | 85 | 90 | φ43 | 6.2 | |
| 8500TOK-G | 10~85 " | 1 " | N850TOK-G | 100~850 | 10 | | 1384 | 58 | 72 | 27 | 93 | 90 | φ45 | 7.1 | |
| 10000TOK-G | 10~100 " | 2 " | N1000TOK-G | 100~1000 | 20 | 25.4 (1") | 1484 | 66 | 74 | 27 | 94 | 90 | φ51 | 7.3 | |
| 14000TOK-G | 20~140 " | 2 " | N1400TOK-G | 200~1400 | 20 | | 1696 | 66 | 74 | 27 | 94 | 90 | φ51 | 9 | |

LTDK CLUTCH RELEASE TORQUE SCREW DRIVERS

Clutch release prevents over-tightening, reduces fatigue.

FEATURES

- Comfortable grip for extended use.
- Light weight and short overall length facilitates jobs.
Sensitive clutch release helps the operator feel when the torque setting is reached.
- Set the required torque value and tighten, all operators tighten consistently.
- Two Phillips bit are included.
- Various hex and box drive bits are available.
- Use for both clockwise and counter-clockwise tightening.
- Accuracy : $\pm 3\%$ of indicated value over the full range, clockwise.
- "H"-models accept standard bits instead of CB type bits.

USING AN LTDK DRIVER

- (1) Select and mount a bit to match the fastener.
- (2) Rotate the adjusting ring and set the desired torque.
- (3) Tighten the fastener clockwise until the clutch releases and there is no more resistance.



N6~50LTDK

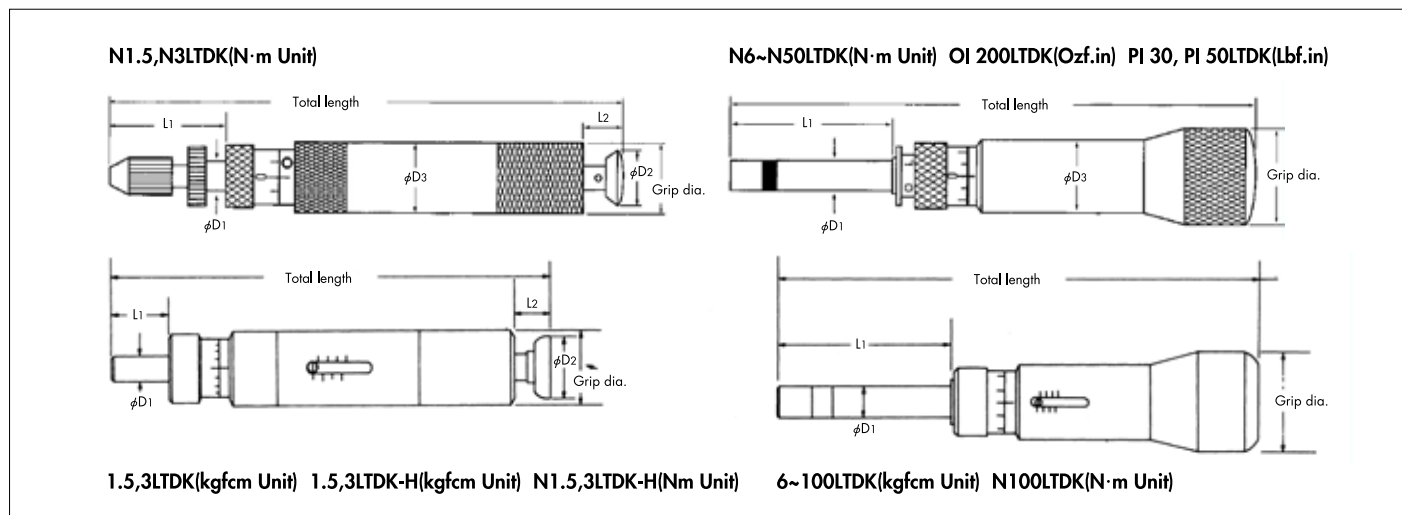

| Model (cN·m/N·m) | Range | Increment | Model (ozf-in/lbf-in) | Range | Increment | Grip dia. | Total length (without bit) | Dimensions (mm) | | | | | Weight | Included Accessory | | |
|---------------------|---------|-----------|--------------------------|---------------|-----------|-----------|-------------------------------|-----------------|------|------|------|------|--------|--------------------|--------------------------|----------|
| | | | | | | | | Body | | | | | | g | Bits | |
| | | cN·m/N·m | | ozf-in/lbf-in | | mm | mm | L1 | L2 | φ D1 | φ D2 | φ D3 | | | Phillips | Bit type |
| N1.5LTDK | 1~15 | 0.1 | | | | 16 | 107 | 22 | 10.5 | 5.5 | 14.4 | 16 | 57 | No.0 No.1 | KANON bits CB type | |
| N3LTDK | 2~30 | 0.2 | | | | 25 | 110 | 26 | | | | 20 | 99 | | | |
| N6LTDK | 5~60 | 0.5 | | | | 34 | 157 | 51 | | | | 25 | 214 | No.0 No.1 | Standard bits SB type | |
| N12LTDK | 20~120 | 1 | OI 200LTDK | 40~200 | 1 | 40 | 200 | 63 | | | | 34 | 436 | No.1 No.2 | | |
| N20LTDK | 40~200 | 1 | | | | 45 | 235 | 100 | | | | 35 | 762 | No.2, No.3 | Included | |
| N30LTDK | 40~300 | 1 | PI 30LTDK | 4~30 | 0.1 | | | | | | | | | | | |
| N50LTDK | 100~500 | 2.5 | PI 50LTDK | 10~50 | 0.25 | | | | | | | | | | | |
| N100LTDK | 4~10 | 0.05 | | | | | | | | | | | | | | |

| Model (kgf·cm/cN·m) | Range | Increment | Grip dia. | Total length (without bit) | Dimensions (mm) | | | | | Weight | Included Accessory | | |
|------------------------|----------------|-------------|-----------|-------------------------------|-----------------|----|------|------|------|--------|--------------------|-----------------------|--------------------------|
| | | | | | Body | | | | | | Bits | | Extension Bar |
| | | | | | L1 | L2 | φ D1 | φ D2 | φ D3 | | g | Phillips | |
| 1.5LTDK | 0.1~1.5 kgf·cm | 0.01 kgf·cm | 16 | 99 | 14 | 9 | 5.5 | 14.4 | | 50 | No.0 No.1 | KANON bits OB type | |
| 3LTDK | 0.2~3 " | 0.02 " | | | | | | | | | 25 | | |
| 6LTDK | 0.5~6 " | 0.05 " | 30 | 157 | 57 | | | | 25 | 190 | | No.1 No.2 | Standard bits SB type |
| 12LTDK | 2~12 " | 0.1 " | | | | | | | | | 34 | | |
| 20LTDK | 4~20 " | 0.1 " | 40 | 235 | 100 | | | | | 762 | | No.2, No.3 | Included |
| 30LTDK | 4~30 " | 0.1 " | | | | | | | | | 45 | | |
| 50LTDK | 10~50 " | 0.25 " | 16 | 111 | 26 | 9 | 10 | 14.4 | 35 | 60 | | No.0 No.1 | |
| 100LTDK | 40~100 " | 0.5 " | | | | | | | | | 16 | | |
| 1.5LTDK-H | 0.1~1.5 " | 0.01 " | 16 | 111 | 26 | 9 | 10 | 14.4 | 35 | 60 | | No.0 No.1 | |
| 3LTDK-H | 0.2~3 " | 0.02 " | | | | | | | | | 16 | | |
| N1.5LTDK-H | 1~15 cN·m | 0.1 cN·m | 16 | 111 | 26 | 9 | 10 | 14.4 | 35 | 60 | | No.0 No.1 | |
| N3LTDK-H | 2~30 " | 0.2 " | | | | | | | | | 16 | | |

STDK PRE-SET TORQUE DRIVERS

Clutch release prevents over tightening.



FEATURES

- A single function driver, used for a single torque setting.
 - Most suited for tightening multiple same-size fasteners at the same torque in a production line.
 - Setting confirmation unnecessary.
 - Light weight and short overall length facilitates jobs. Sensitive clutch release helps the operator feel when the torque setting is reached.
 - All operators tighten consistently.
 - Two Phillips bit are included.
 - Various hex and box drive bits are available.
 - Accuracy : ±3% of set value, clockwise.
- * Please specify required set torque when you order.

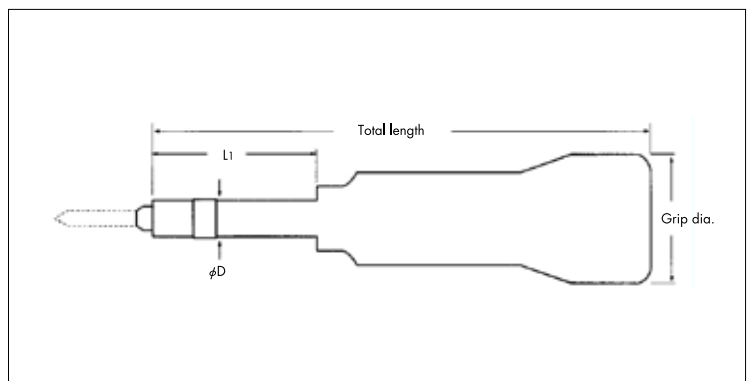

| Model (kgf·cm) | Range | Model (cN·m/N·m) | Range | Model (ozf-in/lbf-in) | Range | Grip dia. | Total length (without bit) | Dimensions (mm) | | Weight | Included Accessory | | |
|-------------------|---------|---------------------|-----------|--------------------------|-------------|-----------|-------------------------------|-----------------|-----|--------|--------------------|-----------------------|------------------|
| | | | | | | | | Body | | | Bits | | Extension Bar |
| | | | | | | | | L1 | φ D | | g | Phillips | |
| 1.5STDK | 0.1~1.5 | N1.5STDK | 1~15 cN·m | OI 22STDK | 2~22 ozf-in | 16 | 92 | 22 | 8 | 45 | No.0 No.1 | KANON bits CB type | |
| 3STDK | 0.2~3 | N3STDK | 2~30 " | OI 44STDK | 4~44 " | | | | | | 25 | | |
| 6STDK | 1~6 | N6STDK | 10~60 " | OI 80STDK | 20~80 " | 30 | 116 | 54 | 148 | 200 | | No.1 No.2 | Included |
| 12STDK | 2~12 | N12STDK | 20~120 " | OI 200STDK | 40~200 " | | | | | | 35 | | |
| 20STDK | 4~20 | N20STDK | 40~200 " | PI 20STDK | 4~20 lbf-in | 45 | 126 | 56 | 220 | 790 | | | |
| 30STDK | 4~30 | N30STDK | 40~300 " | PI 30STDK | 4~30 " | | | | | | 45 | | |
| 50STDK | 10~50 | N50STDK | 100~500 " | PI 50STDK | 10~50 " | 45 | 248 | 126 | 11 | 790 | | No.2, No.3 | |
| 100STDK | 40~100 | N100STDK | 4~10 N·m | PI 100STDK | 40~100 " | | | | | | 45 | | |

DPSK DIAL GAUGE TORQUE DRIVERS

Suited for light torque, general tightening work, inspections. Easy to handle, easy to read scale.

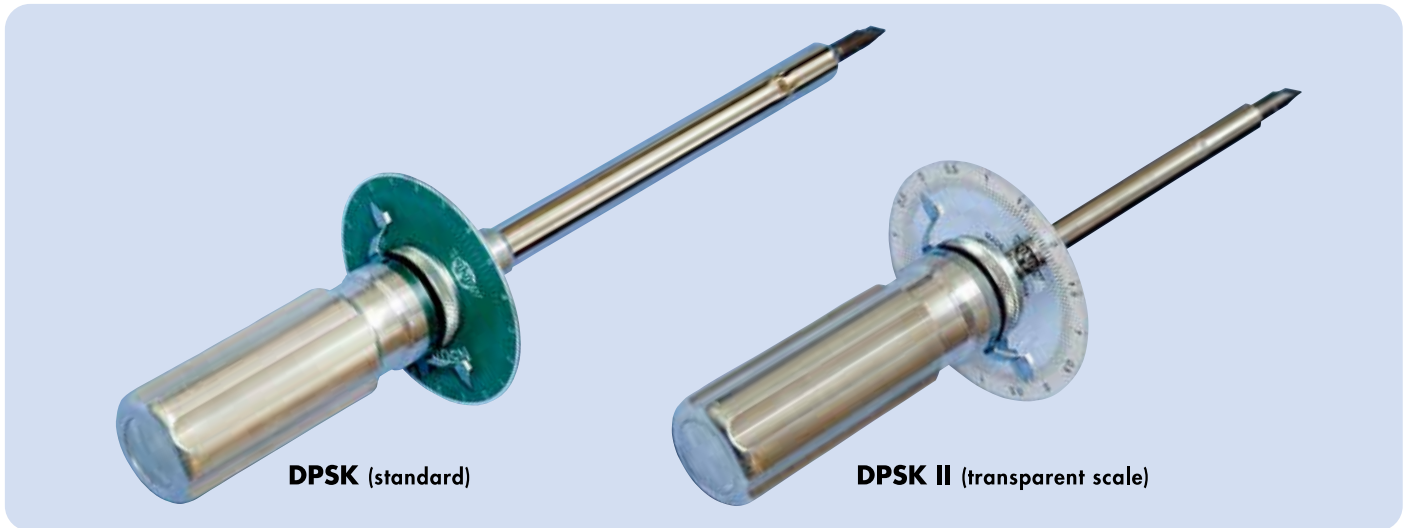

FEATURES

■ DPSK (standard)

- A light torque driver well suited for general tightening, inspections and break tests.
- Easy handling with a direct reading dial gauge.
- Use for both clockwise and counterclockwise tightening.
- Peak torque indicator works in both directions, too.
- Large, easily read dial gauge.

■ DPSK II (transparent scale)

- The transparent scale makes engaging the fastener easier.
- For both models, accuracy is $\pm 3\%$ of the indicated value over the full range

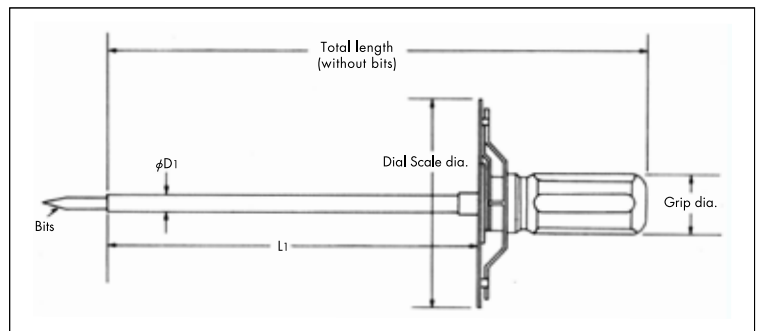

USING A DPSK DRIVER

- (1) Mount a bit matching the fastener being
- (2) Loosen the peak indicator ring.
- (3) Set the peak indicator to 0.
- (4) Tighten the fastener while observing the scale.

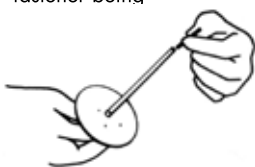

| Model (kgf·cm) | Range (CW/CCW) | Increment | Model (cN·m/N·m) | Range (CW/CCW) | Increment | Dial dia. φmm | Grip dia. φmm | Total length (without bit) mm | Dimensions (mm) | | Weight kg | Included Accessory Bits | | | |
|----------------|----------------|-----------|------------------|----------------|-----------|---------------|---------------|-------------------------------|-------------------|--------|--------------|--------------------------|-----------------------|------|------|
| | | | | | | | | | Driver shaft (mm) | Weight | | Phillips | Bit type | | |
| 1DPSK | 0.2~1 | 0.025 | N1DPSK | 2~10 cN·m | 0.25 cN·m | 78 | 22 | 217 | 152 | 6 | 0.075 | No.0 No.1 | KANON bits OB type | | |
| 2DPSK | 0.5~2 | 0.05 | N2DPSK | 5~20 " | 0.5 " | | | 195 | 130 | | | | | | |
| 5DPSK | 1~5 | 0.2 | N5DPSK | 10~50 " | 2 " | | | 208 | 143 | | | | | | |
| 10DPSK | 2~10 | 0.2 | N10DPSK | 20~100 " | 2 " | | | 222 | 130 | | | | | 12 | 0.33 |
| 20DPSK | 5~20 | 0.5 | N20DPSK | 0.5~2 N·m | 0.05 N·m | | | 242 | | | | | | 0.36 | |
| 50DPSK | 10~50 | 2 | N50DPSK | 1~5 " | 0.2 " | 36 | 300 | 188 | 14 | 0.47 | No.1 No.2 | Standard bits SB type | | | |
| 10DPSK(II) | 2~10 | 0.2 | N10DPSK(II) | 20~100 cN·m | 2 cN·m | 78 | 33 | 222 | 130 | 12 | | | 0.29 | | |
| 20DPSK(II) | 5~20 | 0.5 | N20DPSK(II) | 0.5~2 N·m | 0.05 N·m | | | 242 | | | | | 0.32 | | |
| 50DPSK(II) | 10~50 | 2 | N50DPSK(II) | 1~5 " | 0.2 " | | | 36 | | | | | 300 | 188 | 14 |

SGK TORQUE GAUGES

Capable of accurately measuring very low torque values.

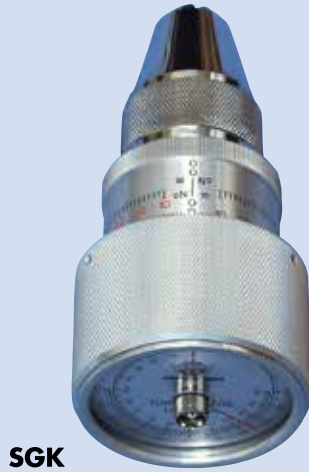

SGK

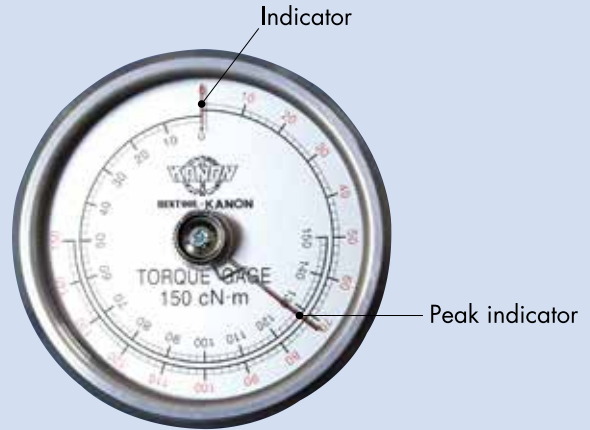

SGK-G (with peak indicator)

* Peak indicator is optional

FEATURES

- Due to their miniature design and light weight, these gauges are convenient and easy to carry.
- A three part chuck with knurled surface enables firmly gripping even odd shapes.
- The inset scale face helps avoid incidental damage.
- The gauges measure clockwise and counterclockwise.
- With scales on the sides and the face, torque readings can be obtained either way.
- Accuracy : $\pm 3\%$ of the indicated value over the full range

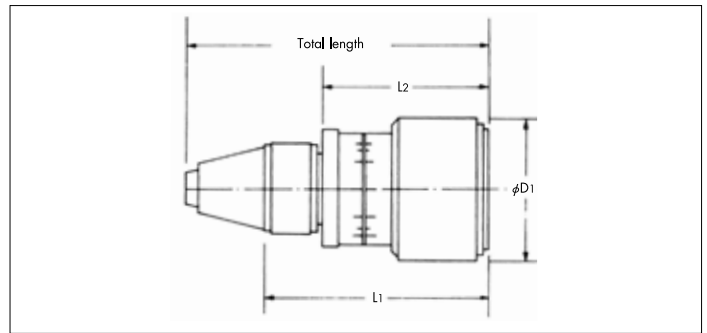

USING AN SGK GAUGE

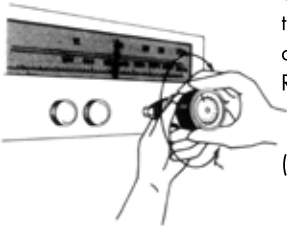

Starting torque can be measured with the chuck gripping a knob or shaft of an electronic device.
Rotate clockwise or counterclockwise.

(Rotate CW or CCW)



- If you would like SGK with a peak indicator, please specify "SGK-G" on your purchase order.
ex) N150(I)SGK-G

Three part chuck

| Model (gf-cm/kgf-cm) | Range (CW/CCW) | Increment | Model (mN·m/cN·m) | Range (CW/CCW) | Increment | Chucking dia. φmm | Total length mm | Dimensions (mm) | | Weight kg | |
|-------------------------|-------------------|--------------|----------------------|-------------------|-----------|-------------------------|-----------------------|------------------|------------------------------|--------------|------|
| | | | | | | | | Grip dia. φD1 | Total length (without chuck) | | |
| | | gf-cm/kgf-cm | | | mN·m/cN·m | | | L1 | L2 | | |
| 90 (I) SGK | 10~90 | 2 | N90 (I) SGK | 1~9 | 0.2 | 1-6.5 | 106 | 43 | 81 | 57.5 | 0.29 |
| 150 (I) SGK | 20~150 | 2 | N150 (I) SGK | 2~15 | 0.2 | | | | | | |
| 300 (I) SGK | 40~300 | 5 | N300 (I) SGK | 4~30 | 0.5 | | | | | | |
| 600 (I) SGK | 50~600 | 10 | N600 (I) SGK | 5~60 | 1 | | | | | | |
| 1200 (I) SGK | 100~1200 | 20 | N1200 (I) SGK | 10~120 | 2 | | | | | | |
| 2400 (I) SGK | 200~2400 | 50 | N2400 (I) SGK | 20~240 | 5 | | | | | | |
| 1.5 (II) SGK | 0.1~1.5 | 0.02 | N1.5 (II) SGK | 1~15 | 0.2 | 1-8.5 | 134 | 63 | 100 | 73 | 0.6 |
| 2.4 (II) SGK | 0.2~2.4 | 0.02 | N2.4 (II) SGK | 2~24 | 0.2 | | | | | | |
| 3.6 (II) SGK | 0.4~3.6 | 0.05 | N3.6 (II) SGK | 4~36 | 0.5 | | | | | | |
| 6 (II) SGK | 0.5~6 | 0.1 | N6 (II) SGK | 5~60 | 1 | | | | | | |
| 9 (II) SGK | 1~9 | 0.2 | N9 (II) SGK | 10~90 | 2 | | | | | | |
| 15 (II) SGK | 1~15 | 0.2 | N15 (II) SGK | 10~150 | 2 | | | | | | |

KDTA-SV DIGITAL TORQUE ANALYZERS

Enhanced digital processor system. Provides high performance with digital wrenches.

FEATURES

- LED display eliminates reading errors.
- Processor chip assures measurement with high reliability and accuracy.
- The display unit angle can be adjusted approximately 90°.
- Can be connected to various optional equipment (printer, personal computer, external input keyboard).
- Saves time and helps speed up work.
- Equipped with a kgf·cm/N·m selector switch.
- Operator can set min/max percentage parameters from 0–10%.
- Analyzer can indicate in or out of specification with a green or red lamp respectively.

SPECIFICATIONS

- Power source : AC100-240V 50/60Hz
- Accuracy : ±1% of the indicated value +1 increment, over the full range
- Display : red LED (character height : 25mm)
- Operating temperature : 0~40°C



KDTA-2000SV

| Model | Range(CW/CCW) | | English Model | Range(CW/CCW) | | Measuring mode | Unit conversion | Dimensions (mm) | | | Drive size mm | Weight kg | Included Accessory |
|--------------|-----------------|-------------|---------------|-------------------|-------------|---------------------------------------|--|-----------------|---------------|----------------|-------------------------------|-----------|-----------------------------|
| | kgf·cm/kgf·m | N·m | | lbf·in | N·m | | | Overall depth | Overall width | Overall height | | | |
| KDTA-20SV | 2~20 kgf·cm | 0.01 kgf·cm | KDTA-20SV | 1.77~17.70 lbf·in | 0.01 lbf·in | RUN Peak hold Peak to peak hold | Standard kgf·cm N·m English Model lb·in N·m | 120 | 250 | 240 | 12 | 6 | 6.35×12 Socket |
| | 20~200 cN·m | 0.1 cN·m | | 20~200 cN·m | 0.1 cN·m | | | | | | | | |
| KDTA-100SV | 10~100 kgf·cm | 0.1 kgf·cm | KDTA-100SV | 8.9~88.5 lbf·in | 0.1 lbf·in | | | | | | | | |
| | 1~10 N·m | 0.01 N·m | | 1~10 N·m | 0.01 N·m | | | | | | | | |
| KDTA-200SV | 20~200 kgf·cm | 0.1 kgf·cm | KDTA-200SV | 17.7~177.0 lbf·in | 0.1 lbf·in | | | | | | | | |
| | 2~20 N·m | 0.01 N·m | | 2~20 N·m | 0.01 N·m | | | | | | | | |
| KDTA-1000SV | 100~1000 kgf·cm | 1 kgf·cm | KDTA-1000SV | 89~885 lbf·in | 1 lbf·in | | | 180 | 320 | 273 | 14 | 15 | 9.5×14 12.7×14 Socket |
| | 10~100 N·m | 0.1 N·m | | 10~100 N·m | 0.1 N·m | | | | | | | | |
| KDTA-2000SV | 200~2000 kgf·cm | 1 kgf·cm | KDTA-2000SV | 177~1770 lbf·in | 1 lbf·in | | | | | | | | |
| | 20~200 N·m | 0.1 N·m | | 20~200 N·m | 0.1 N·m | | | | | | | | |
| KDTA-6000SV | 600~6000 kgf·cm | 1 kgf·cm | | | | 220 | 380 | 265 | 26 | 25 | 19.05×26 12.7×26 Socket | | |
| | 60~600 N·m | 0.1 N·m | | | | | | | | | | | |
| KDTA-10000SV | 10~100 kgf·m | 0.1 kgf·m | | | | 30 | | | 30 | | 19.05×30 25.4×30 Socket | | |
| | 100~1000 N·m | 1 N·m | | | | | | | | | | | |

DRIVE ATTACHMENTS (Optional)

■ KDTA-20SV/100SV/200SV 200SVH



■ KDTA-1000SV/2000SV 1000SVH/2000SVH, 2000SVII



■ KDTA-3000SVH

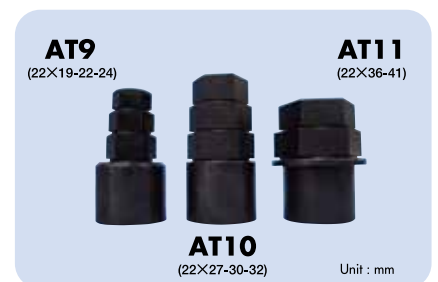

KDTA-SVH

LARGE DIGITAL TORQUE ANALYZERS



FEATURES

- LED display eliminates reading errors.
- Processor chip assures measurement with high reliability and accuracy.
- The display unit angle can be adjusted approximately 90°.
- Can be connected to various optional equipment (printer, personal computer, external input keyboard).
- Saves time and helps speed up work.
- Equipped with a kgf-cm/N-m selector switch.

SPECIFICATIONS

- Power : AC100-240V 50/60Hz
- Accuracy : $\pm 1\%$ of the indicated value +1 increment, over the full range
- Display : red LED (character height : 25mm)
- Operating temperature range : 0~40°C

| Model | Range(CW/CCW) | Increment | English Model | Range(CW/CCW) | Increment | Measuring mode | Unit conversion | Drive size | Weight | Included Accessory |
|--------------|-----------------|------------|---------------|-------------------|------------|---------------------------------------|-------------------------------|------------|-------------------------------------|-----------------------------------|
| | kgf-cm/kgf-m | N-m | | lbf-in/lbf-ft | N-m | | | mm | kg | |
| KDTA-200SVH | 20~200 kgf-cm | 0.1 kgf-cm | KDTA-200SVH | 17.7~177.0 lbf-in | 0.1 lbf-in | RUN Peak hold Peak to peak hold | Standard kgf-cm N-m | 12 | 10 | 6.35×12 Socket |
| | 2~20 N-m | 0.01 N-m | | 2~20 N-m | 0.01 N-m | | | | | |
| KDTA-1000SVH | 100~1000 kgf-cm | 1 kgf-cm | KDTA-1000SVH | 89~885 lbf-in | 1 lbf-in | | English Model lb-in N-m | 14 | 17.5 | 9.5×14 Socket |
| | 10~100 N-m | 0.1 N-m | | 10~100 N-m | 0.1 N-m | | | | | |
| KDTA-2000SVH | 200~2000 kgf-cm | 1 kgf-cm | KDTA-2000SVH | 177~1770 lbf-in | 1 lbf-in | | Standard kgf-cm N-m | 22 | 29 | 12.7×22 Socket 19.05×22 Socket |
| | 20~200 N-m | 0.1 N-m | | 20~200 N-m | 0.1 N-m | | | | | |
| KDTA-3000SVH | 300~3000 kgf-cm | 1 kgf-cm | KDTA-3000SVH | 22.1~221.2 lbf-ft | 0.1 lbf-ft | English Model lb-ft N-m | 26 | 80 | 12.7×26 Socket 19.05×26 Socket | |
| | 30~300 N-m | 0.1 N-m | | 30~300 N-m | 0.1 N-m | | | | | |
| KDTA-6000SVH | 600~6000 kgf-cm | 1 kgf-cm | KDTA-6000SVH | 44.2~442.5 lbf-ft | 0.1 lbf-ft | English Model lb-ft N-m | 30 | 65 | 12.7×30, 19.05×30 25.4×30 Socket | |
| | 60~600 N-m | 0.1 N-m | | 60~600 N-m | 0.1 N-m | | | | | |
| KDTA10000SVH | 10~100 kgf-m | 0.1 kgf-m | KDTA-10000SVH | 74~737 lbf-ft | 1 lbf-ft | | | | | |
| | 100~1000 N-m | 1 N-m | | 100~1000 N-m | 1 N-m | | | | | |

TPK-3

STANDARD PRINTER

FEATURES

- Indicates in or out of specification on the led display and print out.
- * Printer cables are options. CT-1 is for DTC series.
CSV-1 is for KDTA-SV and KDTA-SVH series.



KDTA-SVII DIGITAL TORQUE ANALYZERS

Highly accurate and economical torque analyzer, easy for operators to use on the job site.



FEATURES

- LED display eliminates reading errors.
- Processor chip assures measurement with high reliability and accuracy.
- Connects to an optional printer.
- Saves time and helps speed up work.
- Equipped with a kgf-cm/N·m selector switch.

SPECIFICATIONS

- Power : AC100-240V 50/60Hz
- Accuracy : $\pm 1\%$ of the indicated value +1 increment, over the full range
- Display : red LED (character height : 25mm)
- Operating temperature range : 0~40°C

| Model | Torque measuring range | Increment | English Model | Torque measuring range | Increment | Drive size | Display | Weight (kg) |
|------------------|------------------------|----------------|------------------|------------------------|---------------|------------|---------|-------------|
| KDTA-2000SV (II) | 50~2000kgf-cm/5~200N·m | 1kgf-cm/0.1N·m | KDTA-2000SV (II) | 35~1770lb-in/5~200N·m | 1lb-in/0.1N·m | 14mm | Red LED | 11.5 |

KDTA-SVEX AUTOMATIC DIGITAL TORQUE ANALYZERS

FEATURES

- LED display eliminates reading errors.
- Processor chip assures measurement with high reliability and accuracy.
- Saves time and helps speed up work.
- Equipped with a kgf-cm/N·m selector switch.

SPECIFICATIONS

- Power : AC100-240V 50/60Hz
- Accuracy : $\pm 1\%$ of the indicated value +1 increment, over the full range
- Display : red LED
- Operating temperature range : 0~40°C

| Model | Range(CW/CCW) | Increment | Measuring mode | Unit conversion | Drive size |
|----------------|-----------------|-----------|---------------------------------------|---------------------------|------------|
| | kgf-cm/kgf-m | N-m | | | |
| KDTA-6000SVEX | 600~6000 kgf-cm | 1 kgf-cm | RUN Peak hold Peak to peak hold | Standard kgf-cm N·m | 26 |
| | 60~600 N·m | 0.1 N·m | | | |
| KDTA-10000SVEX | 10~100 kgf-m | 0.1 kgf-m | | | 30 |
| | 100~1000 N·m | 1 N·m | | | |
| KDTA-20000SVEX | 20~200 kgf-m | 0.1 kgf-m | | | 32 |
| | 200~2000 N·m | 1 N·m | | | |



* Calibration Test kits are options.

KDTA-DH

DIGITAL TORQUE ANALYZERS FOR TORQUE DRIVERS



KDTA-8DH

KDTA-8DH / KDTA-80DH

FEATURES

- Designed for LTKD and STDK
 - Battery powered
 - Battery Charger is available for AC 100V~240V 50/60Hz
 - Lightweight plastic case
 - kgf-cm/N-m / lbf-in unit conversion
- MODE : RUN (constantly indicates torque value.)
PEAK HOLD
PEAK TO PEAK-HOLD
 - AUTO RESET : Timer function available
 - DATA OUTPUT : Digital output
 - PRINTER : TPK-3 (Optional)
 - Accuracy : $\pm 1\%$ of the indicated value +1 increment, over the full range

| Model | Range | Increment | Measuring mode | Battery | Size | Weight (kg) |
|-----------|---|---|---------------------------------------|--------------|----------------------------------|-------------|
| KDTA-8DH | 3~800mN·m 0.3~80cN·m 0.03~8kgf·cm 0.03~7lbf·in | 0.1mN·m 0.01cN·m 0.001kgf·cm 0.001lbf·in | RUN Peak hold Peak to Peak hold | Rechargeable | 230 (W) × 123 (D) × 65 (H) mm | 1.8 |
| KDTA-80DH | 3~800cN·m 0.03~8N·m 0.3~80kgf·cm 0.3~70lbf·in | 0.1cN·m 0.0001N·m 0.01kgf·cm 0.01lbf·in | RUN Peak hold Peak to Peak hold | Rechargeable | 230 (W) × 123 (D) × 65 (H) mm | 1.8 |

KDTA-D

DIGITAL TORQUE ANALYZERS FOR ELECTRIC DRIVERS

KDTA-10D / KDTA-100D

FEATURES

- Battery is rechargeable.
 - For any brand of the Electric Driver
 - Battery Charger is available for AC 100V~240V 50/60Hz
- MODE : RUN (constantly indicates torque value.)
PEAK HOLD
PEAK TO PEAK-HOLD
 - AUTO RESET : Timer function available
 - DATA OUTPUT : Digital output
 - PRINTER : TPK-3 (Optional)
 - Accuracy : $\pm 1\%$ of the indicated value +1 increment, over the full range



| Model | Range | Increment | Measuring mode | Battery | Size | Weight (kg) |
|-----------|---|-------------------------------------|---------------------------------------|--------------|----------------------------------|-------------|
| KDTA-10D | 1.5~100.0cN·m 0.15~10.00kgf·cm 0.13~10.00lbf·in | 0.1cN·m 0.01kgf·cm 0.01lbf·in | RUN Peak hold Peak to Peak hold | Rechargeable | 230 (W) × 123 (D) × 65 (H) mm | 1.18 |
| KDTA-100D | 15~1000cN·m 1.5~100.0kgf·cm 1.3~100.0lbf·in | 1cN·m 0.1kgf·cm 0.1lbf·in | RUN Peak hold Peak to Peak hold | Rechargeable | 230 (W) × 123 (D) × 65 (H) mm | 1.18 |

CTK-XL CAP TESTER

DIGITAL CAP TORQUE ANALYZERS

Digital measurement of opening and closing torque on container caps.



CTK-XL

* The bottle is not included.

FEATURES

- Optimal for measuring torque values opening or closing caps on containers for cosmetic products, medical products, foods, etc.
- Up to 100 measurements can be stored in memory.
- Upper and lower limit values can be set.
- Capable of measuring clockwise and counterclockwise values.
- The testers will handle containers in diameters ranging 10~100mm and 22~180mm.
- Accuracy : $\pm 1\%$ of indicated value +1 increment, over the full range

MODE : Power source ON/OFF switch, MODE selection

CLR : [0] reset switch, data cleared

UP : Upper limit value set switch

DW : Lower limit value set switch

SET : save data



| Model | Torque range | Increment | Accuracy | Power source | Weight | Chuck diameter (mm) |
|-----------|--------------|------------|---|---------------------------|--------|-----------------------|
| CTK-30XL | 3~30kgf·cm | 0.02kgf·cm | $\pm 1\%$ of indicated value +1 increment over the full range | AC100~240V (adapter DC6V) | 11kg | $\phi 10\sim\phi 100$ |
| CTK-100XL | 10~100kgf·cm | 0.1kgf·cm | | | | $\phi 22\sim\phi 180$ |
| CTK-3NXL | 30~300cN·m | 0.2cN·m | $\pm 1\%$ of indicated value +1 increment over the full range | AC100~240V (adapter DC6V) | 11kg | $\phi 10\sim\phi 100$ |
| CTK-10NXL | 1~10N·m | 0.01N·m | | | | $\phi 22\sim\phi 180$ |

TK TENSION GAUGES

Demonstrating KANON's measuring versatility.
Great performance whether measuring vertically or horizontally.

FEATURES

- Measures pushing, pulling force and spring tension.
Our tension gauges are designed to indicate precise increments of force.
- Use the gauges for taking horizontal measurements. Just add the correcting value to the indicated value (see the table below). A peak indicator is available for TK500 to TK300 and TK500cN to TK3000cN.
- Accuracy : ± 1 increment



TK

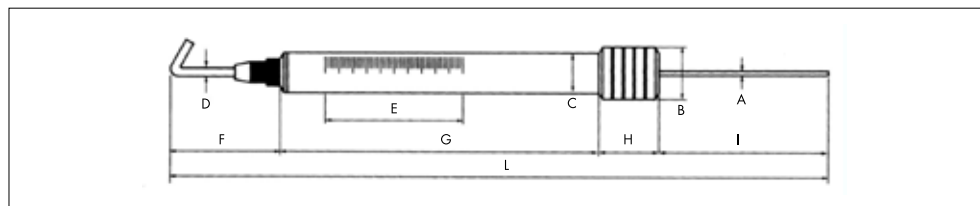

| Model (g) | Range (g) | Incr. (g) | A mm | B mm | C mm | D mm | E mm | F mm | G mm | H mm | I mm | L mm | Weight (g) | Correcting value for horizontal measurements (g) |
|-----------|-----------|-----------|------|------|------|------|------|------|------|------|------|------|------------|--|
| TK10 | 0 ~ 10 | 0.5 | 1.5 | 16 | 13 | 1.5 | 40 | 19 | 98 | 15 | 48 | 180 | 30 | 3 |
| TK30 | 0 ~ 30 | 1 | 1.5 | 16 | 13 | 1.5 | 60 | 19 | 113 | 15 | 66 | 213 | 30 | 3 |
| TK50 | 0 ~ 50 | 1 | 1.5 | 16 | 13 | 1.5 | 60 | 19 | 113 | 15 | 66 | 213 | 30 | 3 |
| TK110 | 0 ~ 110 | 2 | 2 | 16 | 13 | 2 | 60 | 27.5 | 113 | 15 | 65.5 | 221 | 35 | 10 |
| TK200 | 0 ~ 200 | 5 | 2 | 16 | 13 | 2 | 60 | 27.5 | 113 | 15 | 65.5 | 221 | 35 | 10 |
| TK300 | 0 ~ 300 | 5 | 2 | 16 | 13 | 2 | 60 | 27.5 | 113 | 15 | 65.5 | 221 | 35 | 10 |
| TK500 | 0 ~ 500 | 10 | 3 | 20 | 16 | 2.6 | 56 | 43 | 131 | 25 | 69 | 268 | 78 | 30 |
| TK600 | 0 ~ 600 | 20 | 3 | 20 | 16 | 2.6 | 56 | 43 | 131 | 25 | 69 | 268 | 78 | 30 |
| TK1000 | 0 ~ 1000 | 25 | 3 | 20 | 16 | 2.6 | 56 | 43 | 131 | 25 | 69 | 268 | 78 | 30 |
| TK1500 | 0 ~ 1500 | 50 | 3 | 20 | 16 | 2.6 | 56 | 43 | 131 | 25 | 69 | 268 | 78 | 30 |
| TK2000 | 0 ~ 2000 | 50 | 3 | 20 | 16 | 2.6 | 56 | 43 | 131 | 25 | 69 | 268 | 78 | 30 |
| TK2500 | 0 ~ 2500 | 50 | 3 | 20 | 16 | 2.6 | 62 | 43 | 143 | 25 | 74 | 285 | 85 | 50 |
| TK3000 | 0 ~ 3000 | 50 | 3 | 20 | 16 | 2.6 | 62 | 43 | 143 | 25 | 74 | 285 | 85 | 50 |
| TK4000 | 0 ~ 4000 | 50 | 4 | 25 | 22 | 3.5 | 68 | 43 | 178 | 35 | 82 | 338 | 200 | 100 |
| TK5000 | 0 ~ 5000 | 100 | 4 | 25 | 22 | 3.5 | 68 | 43 | 178 | 35 | 82 | 338 | 200 | 100 |
| TK7000 | 0 ~ 7000 | 200 | 4 | 25 | 22 | 3.5 | 68 | 43 | 178 | 35 | 82 | 338 | 205 | 100 |
| TK10000 | 0 ~ 10000 | 200 | 4 | 25 | 22 | 3.5 | 68 | 43 | 178 | 35 | 82 | 338 | 205 | 100 |
| TK15000 | 0 ~ 15000 | 200 | 8 | 35 | 32 | 7 | 95 | 83 | 230 | 35 | 145 | 493 | 600 | 250 |
| TK20000 | 0 ~ 20000 | 200 | 8 | 35 | 32 | 7 | 118 | 83 | 280 | 35 | 140 | 538 | 680 | 250 |
| TK30000 | 0 ~ 30000 | 500 | 8 | 40 | 38 | 7 | 130 | 83 | 305 | 35 | 172 | 595 | 830 | 350 |

| Model (cN) | Range (cN) | Incr. (cN) | A mm | B mm | C mm | D mm | E mm | F mm | G mm | H mm | I mm | L mm | Weight (g) | Correcting value for horizontal measurements (c-N) |
|------------|------------|------------|------|------|------|------|------|------|------|------|------|------|------------|--|
| TK10cN | 0 ~ 10 | 0.5 | 1.5 | 16 | 13 | 1.5 | 40 | 19 | 98 | 15 | 48 | 180 | 30 | 3 |
| TK30cN | 0 ~ 30 | 1 | 1.5 | 16 | 13 | 1.5 | 60 | 19 | 113 | 15 | 66 | 213 | 30 | 3 |
| TK50cN | 0 ~ 50 | 1 | 1.5 | 16 | 13 | 1.5 | 60 | 19 | 113 | 15 | 66 | 213 | 30 | 3 |
| TK110cN | 0 ~ 110 | 2 | 2 | 16 | 13 | 2 | 60 | 27.5 | 113 | 15 | 65.5 | 221 | 35 | 10 |
| TK200cN | 0 ~ 200 | 5 | 2 | 16 | 13 | 2 | 60 | 27.5 | 113 | 15 | 65.5 | 221 | 35 | 10 |
| TK300cN | 0 ~ 300 | 5 | 2 | 16 | 13 | 2 | 60 | 27.5 | 113 | 15 | 65.5 | 221 | 35 | 10 |
| TK500cN | 0 ~ 500 | 10 | 3 | 20 | 16 | 2.6 | 56 | 43 | 131 | 25 | 69 | 268 | 78 | 30 |
| TK600cN | 0 ~ 600 | 20 | 3 | 20 | 16 | 2.6 | 56 | 43 | 131 | 25 | 69 | 268 | 78 | 30 |
| TK1000cN | 0 ~ 1000 | 25 | 3 | 20 | 16 | 2.6 | 56 | 43 | 131 | 25 | 69 | 268 | 78 | 30 |
| TK1500cN | 0 ~ 1500 | 50 | 3 | 20 | 16 | 2.6 | 56 | 43 | 131 | 25 | 69 | 268 | 78 | 30 |
| TK2000cN | 0 ~ 2000 | 50 | 3 | 20 | 16 | 2.6 | 56 | 43 | 131 | 25 | 69 | 268 | 78 | 30 |
| TK2500cN | 0 ~ 2500 | 50 | 3 | 20 | 16 | 2.6 | 62 | 43 | 143 | 25 | 74 | 285 | 85 | 50 |
| TK3000cN | 0 ~ 3000 | 50 | 3 | 20 | 16 | 2.6 | 62 | 43 | 143 | 25 | 74 | 285 | 85 | 50 |
| TK4000cN | 0 ~ 4000 | 50 | 4 | 25 | 22 | 3.5 | 68 | 43 | 178 | 35 | 82 | 338 | 200 | 100 |
| TK5000cN | 0 ~ 5000 | 100 | 4 | 25 | 22 | 3.5 | 68 | 43 | 178 | 35 | 82 | 338 | 200 | 100 |
| TK7000cN | 0 ~ 7000 | 200 | 4 | 25 | 22 | 3.5 | 68 | 43 | 178 | 35 | 82 | 338 | 205 | 100 |
| TK10000cN | 0 ~ 10000 | 200 | 4 | 25 | 22 | 3.5 | 68 | 43 | 178 | 35 | 82 | 338 | 205 | 100 |
| TK15000cN | 0 ~ 15000 | 200 | 8 | 35 | 32 | 7 | 95 | 83 | 230 | 35 | 145 | 493 | 600 | 250 |
| TK20000cN | 0 ~ 20000 | 200 | 8 | 35 | 32 | 7 | 118 | 83 | 280 | 35 | 140 | 538 | 680 | 250 |
| TK30000cN | 0 ~ 30000 | 500 | 8 | 40 | 38 | 7 | 130 | 83 | 305 | 35 | 172 | 595 | 830 | 350 |

- If you take a measurement horizontally, add the correcting value to the indicated measurement value per the table.



* Peak indicator is optional

- If you would like your TK gauge with a peak indicator, please specify "TK-G" on your purchase order. ex) TK500cN-G

TCSK-99MA

MULTI-FUNCTION TORQUE TASK MANAGER / ANALYZER

The multi-controller, the "Careless Mistake Detector" has a 100-240V multi-input type power system.



This is an extremely useful multi-function controller that can serve many purposes, such as detecting loose joints, eliminating faulty fastener tightening, and task time management through connection with a KANON torque wrench, or torque driver.

FEATURES

- TCSK-99MA connects to KANON SWPM series torque tools.
- The red LED indicators are large and easy-to-read, allowing the operator to check the settings and progress of fastener tightening work at a glance. With visible and audible signals, the TCSK-99MA prevents you from leaving joints loose during fastener tightening work.
- Compared with conventional products, TCSK-99MA offers many different functions at a lower price.
- TCSK-99MA can help manage work processes via external output signals.

* This item does not have the CE mark.

| | |
|---------------------------|--|
| Model | TCSK-99MA |
| Count | 1 to 99 |
| Timer setting | Digital input (set time for each function) |
| Judgement | OK (sounds and LED lights up in green) NG (sounds and LED lights up in red) |
| External input | Start, stop, reset, direction of rotation, work, lock |
| External output | Count OK, work NG/OK, overtime NG, in-time NG |
| Power supply | Input (primary side), switching power type multi-input of 100 to 240 VAC Output(secondary side) 24VDC, 2A 50W |
| Power consumption | 10W |
| Outside dimensions | 209mm (W)×77mm(H)×180mm(D) |
| Weight | approximately 1.7kg |

SWPM Series

TORQUE TOOLS FOR TCSK

SWP tools connect with TCSK-99MA and prevent missing tightening joints.



N-QLK-SWPM

FEATURES

- When the tool clicks, indicating the joint is tightened to the specified torque, a signal is sent to the TCSK-99MA.

SWP TYPES ● Type and torque range

| Model | Available Models |
|-----------|--|
| SPK-SWPM | 80SPK~ 4200SPK N80SPK~ N4200SPK |
| RSPK-SWPM | 80RSPK~ 4200RSPK N80RSPK~ N4200RSPK |
| QSPK-SWPM | PI120QSPK~ PI2800QSPK / PF4200QSPK 120QSPK~ 4200QSPK N120QSPK~ N4200QSPK |
| SPCK-SWPM | 120SPCK~ 4400SPCK N120SPCK~ N4400SPCK |

- Accuracy : $\pm 3\%$ of pre-set value

| | |
|----------|---|
| QLK-SWPM | PI120QLK~ PI2000QLK 120QLK~ 2800QLK N120QLK~ N2800QLK |
| LCK-SWPM | 120LCK~ 2800LCK N120LCK~ N2800LCK |

- Accuracy : $\pm 3\%$ of indicated value over the full range

| | |
|----------|--|
| LTDK-SWP | O1200LTDK / PI30LTDK~ PI50LTDK 12LTDK~ 100LTDK N12LTDK~ N100LTDK |
|----------|--|

- Accuracy : $\pm 3\%$ of indicated value over the full range, clockwise

* Torque wrench setting of N450QLK-SWP less than 10N·m and 450QLK-SWP less than 100kgf·cm does not go signal properly.



BITS

BITS FOR TORQUE DRIVERS

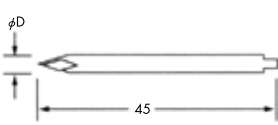
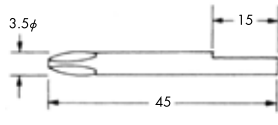
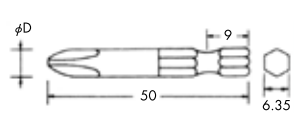
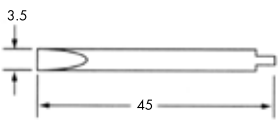
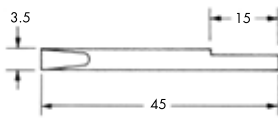
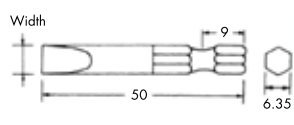
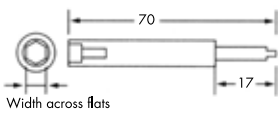
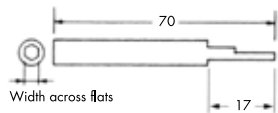
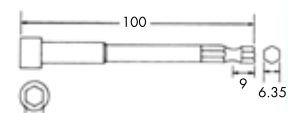
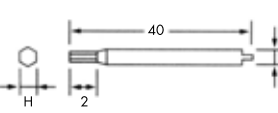
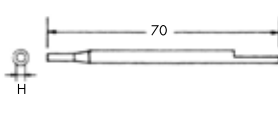
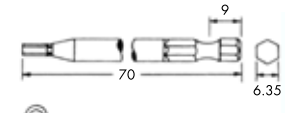
| Type | CB type (KANON bits) | OB type (KANON bits) | SB type (Standard bits) | | | | | | | | | | | | | | | | | | | | | | | | | | | | | | | | | | | | | | | | | | | | | | | | |
|--------------------------|---|---------------------------------|--|-------|-------|---|-----------------|-------|--|-------|---|-----------------|-------|---|--------------------|-------|--|----|-----------|----|------|------|----|------|------|--|---|--------------------|--|--|--|--|--|------|-----|-----|-----|---|--|---|---|----|----|----|--|----|----|----|--|--|--|
| Applicable driver | N1.5, 3 LTKD (N)1.5, 3STDK OI 22, 44, STDK | 1.5, 3 LTKD (N) 1, 2, 5 DPSK | (N)1.5, 3 LTKD-H, (N)6, 12, 20, 30, 50, 100LTKD OI 200LTKD, PI 30, 50, LTKD (N)6, 12, 20, 30, 50, 100STDK OI 80, 200STDK, PI 20, 30, 50, 100STDK (N)10, 20, 50DPSK, (N)10, 20, 50DPSKII DTDK-20, 50EXL, DTDK-N2, NS EXL | | | | | | | | | | | | | | | | | | | | | | | | | | | | | | | | | | | | | | | | | | | | | | | | |
| Phillips |  <p>Unit : mm</p> <table border="1"> <thead> <tr> <th>φD</th> <th>Bit sizes</th> </tr> </thead> <tbody> <tr> <td rowspan="4">3.5φ</td> <td>No.00</td> </tr> <tr> <td>No.0</td> </tr> <tr> <td>No.1</td> </tr> <tr> <td>No.2</td> </tr> </tbody> </table> | φD | Bit sizes | 3.5φ | No.00 | No.0 | No.1 | No.2 |  <p>Unit : mm</p> <table border="1"> <thead> <tr> <th>φD</th> <th>Bit sizes</th> </tr> </thead> <tbody> <tr> <td rowspan="4">3.5φ</td> <td>No.00</td> </tr> <tr> <td>No.0</td> </tr> <tr> <td>No.1</td> </tr> <tr> <td>No.2</td> </tr> </tbody> </table> | φD | Bit sizes | 3.5φ | No.00 | No.0 | No.1 | No.2 |  <p>Unit : mm</p> <table border="1"> <thead> <tr> <th>φD</th> <th>Bit sizes</th> </tr> </thead> <tbody> <tr> <td rowspan="2">4φ</td> <td>No.0</td> </tr> <tr> <td>No.1</td> </tr> <tr> <td rowspan="2">7φ</td> <td>No.2</td> </tr> <tr> <td>No.3</td> </tr> </tbody> </table> | φD | Bit sizes | 4φ | No.0 | No.1 | 7φ | No.2 | No.3 | | | | | | | | | | | | | | | | | | | | | | | | | | |
| φD | Bit sizes | | | | | | | | | | | | | | | | | | | | | | | | | | | | | | | | | | | | | | | | | | | | | | | | | | |
| 3.5φ | No.00 | | | | | | | | | | | | | | | | | | | | | | | | | | | | | | | | | | | | | | | | | | | | | | | | | | |
| | No.0 | | | | | | | | | | | | | | | | | | | | | | | | | | | | | | | | | | | | | | | | | | | | | | | | | | |
| | No.1 | | | | | | | | | | | | | | | | | | | | | | | | | | | | | | | | | | | | | | | | | | | | | | | | | | |
| | No.2 | | | | | | | | | | | | | | | | | | | | | | | | | | | | | | | | | | | | | | | | | | | | | | | | | | |
| φD | Bit sizes | | | | | | | | | | | | | | | | | | | | | | | | | | | | | | | | | | | | | | | | | | | | | | | | | | |
| 3.5φ | No.00 | | | | | | | | | | | | | | | | | | | | | | | | | | | | | | | | | | | | | | | | | | | | | | | | | | |
| | No.0 | | | | | | | | | | | | | | | | | | | | | | | | | | | | | | | | | | | | | | | | | | | | | | | | | | |
| | No.1 | | | | | | | | | | | | | | | | | | | | | | | | | | | | | | | | | | | | | | | | | | | | | | | | | | |
| | No.2 | | | | | | | | | | | | | | | | | | | | | | | | | | | | | | | | | | | | | | | | | | | | | | | | | | |
| φD | Bit sizes | | | | | | | | | | | | | | | | | | | | | | | | | | | | | | | | | | | | | | | | | | | | | | | | | | |
| 4φ | No.0 | | | | | | | | | | | | | | | | | | | | | | | | | | | | | | | | | | | | | | | | | | | | | | | | | | |
| | No.1 | | | | | | | | | | | | | | | | | | | | | | | | | | | | | | | | | | | | | | | | | | | | | | | | | | |
| 7φ | No.2 | | | | | | | | | | | | | | | | | | | | | | | | | | | | | | | | | | | | | | | | | | | | | | | | | | |
| | No.3 | | | | | | | | | | | | | | | | | | | | | | | | | | | | | | | | | | | | | | | | | | | | | | | | | | |
| Slot Drive |  <p>Unit : mm</p> <table border="1"> <thead> <tr> <th>Blade thickness</th> <th>Width</th> </tr> </thead> <tbody> <tr> <td>0.4mm</td> <td>3.5mm</td> </tr> </tbody> </table> | Blade thickness | Width | 0.4mm | 3.5mm |  <p>Unit : mm</p> <table border="1"> <thead> <tr> <th>Blade thickness</th> <th>Width</th> </tr> </thead> <tbody> <tr> <td>0.4mm</td> <td>3.5mm</td> </tr> </tbody> </table> | Blade thickness | Width | 0.4mm | 3.5mm |  <p>Unit : mm</p> <table border="1"> <thead> <tr> <th>Blade thickness</th> <th>Width</th> </tr> </thead> <tbody> <tr> <td>0.4mm</td> <td>4.0mm</td> </tr> <tr> <td>1.0mm</td> <td>7.0mm</td> </tr> </tbody> </table> | Blade thickness | Width | 0.4mm | 4.0mm | 1.0mm | 7.0mm | | | | | | | | | | | | | | | | | | | | | | | | | | | | | | | | | | |
| Blade thickness | Width | | | | | | | | | | | | | | | | | | | | | | | | | | | | | | | | | | | | | | | | | | | | | | | | | | |
| 0.4mm | 3.5mm | | | | | | | | | | | | | | | | | | | | | | | | | | | | | | | | | | | | | | | | | | | | | | | | | | |
| Blade thickness | Width | | | | | | | | | | | | | | | | | | | | | | | | | | | | | | | | | | | | | | | | | | | | | | | | | | |
| 0.4mm | 3.5mm | | | | | | | | | | | | | | | | | | | | | | | | | | | | | | | | | | | | | | | | | | | | | | | | | | |
| Blade thickness | Width | | | | | | | | | | | | | | | | | | | | | | | | | | | | | | | | | | | | | | | | | | | | | | | | | | |
| 0.4mm | 4.0mm | | | | | | | | | | | | | | | | | | | | | | | | | | | | | | | | | | | | | | | | | | | | | | | | | | |
| 1.0mm | 7.0mm | | | | | | | | | | | | | | | | | | | | | | | | | | | | | | | | | | | | | | | | | | | | | | | | | | |
| BOX BITS (Female Hex) |  <p>Unit : mm</p> <table border="1"> <thead> <tr> <th colspan="6">Width across flats</th> </tr> </thead> <tbody> <tr> <td>3</td> <td>4</td> <td>5</td> <td>5.5</td> <td>6</td> <td></td> </tr> </tbody> </table> | Width across flats | | | | | | 3 | 4 | 5 | 5.5 | 6 | |  <p>Unit : mm</p> <table border="1"> <thead> <tr> <th colspan="6">Width across flats</th> </tr> </thead> <tbody> <tr> <td>3</td> <td>4</td> <td>5</td> <td>5.5</td> <td>6</td> <td></td> </tr> </tbody> </table> | Width across flats | | | | | | 3 | 4 | 5 | 5.5 | 6 | |  <p>Unit : mm</p> <table border="1"> <thead> <tr> <th colspan="6">Width across flats</th> </tr> </thead> <tbody> <tr> <td>4</td> <td>5</td> <td>5.5</td> <td>6</td> <td>7</td> <td></td> </tr> <tr> <td>8</td> <td>9</td> <td>10</td> <td>11</td> <td>12</td> <td></td> </tr> <tr> <td>13</td> <td>14</td> <td>17</td> <td></td> <td></td> <td></td> </tr> </tbody> </table> | Width across flats | | | | | | 4 | 5 | 5.5 | 6 | 7 | | 8 | 9 | 10 | 11 | 12 | | 13 | 14 | 17 | | | |
| Width across flats | | | | | | | | | | | | | | | | | | | | | | | | | | | | | | | | | | | | | | | | | | | | | | | | | | | |
| 3 | 4 | 5 | 5.5 | 6 | | | | | | | | | | | | | | | | | | | | | | | | | | | | | | | | | | | | | | | | | | | | | | | |
| Width across flats | | | | | | | | | | | | | | | | | | | | | | | | | | | | | | | | | | | | | | | | | | | | | | | | | | | |
| 3 | 4 | 5 | 5.5 | 6 | | | | | | | | | | | | | | | | | | | | | | | | | | | | | | | | | | | | | | | | | | | | | | | |
| Width across flats | | | | | | | | | | | | | | | | | | | | | | | | | | | | | | | | | | | | | | | | | | | | | | | | | | | |
| 4 | 5 | 5.5 | 6 | 7 | | | | | | | | | | | | | | | | | | | | | | | | | | | | | | | | | | | | | | | | | | | | | | | |
| 8 | 9 | 10 | 11 | 12 | | | | | | | | | | | | | | | | | | | | | | | | | | | | | | | | | | | | | | | | | | | | | | | |
| 13 | 14 | 17 | | | | | | | | | | | | | | | | | | | | | | | | | | | | | | | | | | | | | | | | | | | | | | | | | |
| HEX BITS (Male Hex) |  <p>Unit : mm</p> <table border="1"> <thead> <tr> <th colspan="6">Edge size (H) mm</th> </tr> </thead> <tbody> <tr> <td>1.27</td> <td>1.5</td> <td>2</td> <td>2.5</td> <td>3</td> <td></td> </tr> </tbody> </table> | Edge size (H) mm | | | | | | 1.27 | 1.5 | 2 | 2.5 | 3 | |  <p>Unit : mm</p> <table border="1"> <thead> <tr> <th colspan="6">Edge size (H) mm</th> </tr> </thead> <tbody> <tr> <td>1.27</td> <td>1.5</td> <td>2</td> <td>2.5</td> <td>3</td> <td></td> </tr> </tbody> </table> | Edge size (H) mm | | | | | | 1.27 | 1.5 | 2 | 2.5 | 3 | |  <p>Unit : mm</p> <table border="1"> <thead> <tr> <th colspan="6">Edge size (H) mm</th> </tr> </thead> <tbody> <tr> <td>1.27</td> <td>1.5</td> <td>2</td> <td>2.5</td> <td>3</td> <td></td> </tr> <tr> <td>4</td> <td>5</td> <td>6</td> <td>8</td> <td></td> <td></td> </tr> </tbody> </table> | Edge size (H) mm | | | | | | 1.27 | 1.5 | 2 | 2.5 | 3 | | 4 | 5 | 6 | 8 | | | | | | | | |
| Edge size (H) mm | | | | | | | | | | | | | | | | | | | | | | | | | | | | | | | | | | | | | | | | | | | | | | | | | | | |
| 1.27 | 1.5 | 2 | 2.5 | 3 | | | | | | | | | | | | | | | | | | | | | | | | | | | | | | | | | | | | | | | | | | | | | | | |
| Edge size (H) mm | | | | | | | | | | | | | | | | | | | | | | | | | | | | | | | | | | | | | | | | | | | | | | | | | | | |
| 1.27 | 1.5 | 2 | 2.5 | 3 | | | | | | | | | | | | | | | | | | | | | | | | | | | | | | | | | | | | | | | | | | | | | | | |
| Edge size (H) mm | | | | | | | | | | | | | | | | | | | | | | | | | | | | | | | | | | | | | | | | | | | | | | | | | | | |
| 1.27 | 1.5 | 2 | 2.5 | 3 | | | | | | | | | | | | | | | | | | | | | | | | | | | | | | | | | | | | | | | | | | | | | | | |
| 4 | 5 | 6 | 8 | | | | | | | | | | | | | | | | | | | | | | | | | | | | | | | | | | | | | | | | | | | | | | | | |

PARTS FOR QLK, QSPK AND QCK

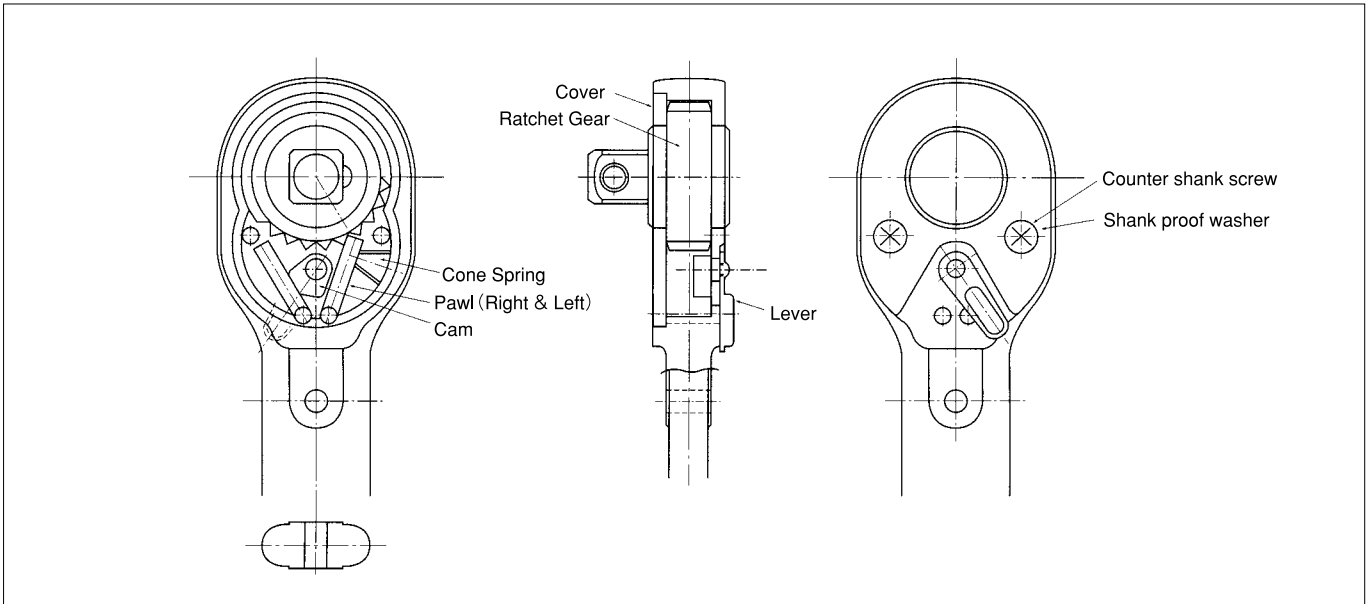

■ Torque unit and conversion table

| | Metric unit | SI unit | Imperial unit |
|---------------------------------|---|--|--|
| Torque unit | kgf·cm kgf·m gf·cm | N·m cN·m | lbf·in lbf·ft OZf·in |
| Conversion in unit | 1 kgf·m=100 kgf·cm 1 kgf·cm=1000 gf·cm 1 kgf·cm=10 kgf·mm | 1 N·m=100 cN·m | 1 lbf·ft=12 lbf·in 1 lbf·in=16 OZf·in |
| Conversion between units | 1 kgf·cm=0.098065 N·m 1 kgf·cm=0.867962 lbf·in 1 kgf·cm=0.072330 lbf·ft | 1 N·m=10.1972 kgf·cm 1 N·m=8.85 lbf·in 1 N·m=0.737562 lbf·ft | 1 lbf·in=1.153 kgf·cm 1 lbf·in=0.112985 N·m 1 lbf·ft=13.825 kgf·cm 1 lbf·ft=1.355 N·m |
| Force unit | 1 kgf =9.807 N 1 kgf =2.205 lbf | 1 N=0.101972 kgf 1 N=0.224809 lbf | 1 lbf=0.453592 kgf 1 lbf=4.448 N (1 lbf=16 OZf) |
| Length unit | 1 cm=0.393701 in | 1 m=3.281 ft | 1 in=2.54 cm 1 ft=0.305 m (1 ft=12 in) |



<http://www.bestool-kanon.co.jp>

Improvement specifications subject to change without notice.

Distributed by:

Produced by :

NAKAMURA MFG. CO., LTD.

4-4, Ohi 4-Chome, Shinagawa-ku, Tokyo 140-0014, Japan

2015.02-7000